

Installation manual

CCB

CCB with alarm

CCB with reserve

CCB with reserve and alarm

SHUT-OFF BOX

Table of contents











| | |
|---|----|
| 1 General safety instructions | 4 |
| 2 Product types and symbols | 5 |
| 2.1 Labelling | 6 |
| 2.1.1 CCB label..... | 6 |
| 2.1.2 Shut-off box label..... | 6 |
| 3 Schematic overview (P&ID)..... | 7 |
| 3.1 CCB 1-5 gases (available options)..... | 7 |
| 3.2 CCB with reserve (available options) | 7 |
| 3.3 CCB 6 gases (Gasmon3 alarm) | 8 |
| 3.4 CCB with contact gauges (Gasmon3 alarm) | 8 |
| 3.5 SHUT-OFF box..... | 9 |
| 3.6 SHUT-OFF box with pressure gauge | 9 |
| 4 Installation and connection of components | 10 |
| 4.1 Sunken mounted box measurements..... | 10 |
| 4.2 Surface mounted box measurements..... | 11 |
| 4.3 Box installation..... | 11 |
| 4.4 Pipe soldering..... | 12 |
| 4.5 Door frame..... | 12 |
| 4.6 Surface mounted Medican slave alarm | 13 |
| 4.7 Sunken mounted Medican slave alarm | 13 |
| 4.8 Surface mounted Gasmon3 slave alarm | 14 |
| 4.9 Sunken mounted Gasmon3 slave alarm | 15 |
| 5 Electrical connection..... | 16 |
| 5.1 Connection to the mains supply | 16 |
| 5.2 Wiring example with all options for Medican alarm | 17 |
| 5.3 Wiring example with all options for Gasmon3 alarm | 18 |
| 5.4 Connection with Medican slave alarm | 19 |
| 5.5 Connection with Gasmon3 slave alarm | 20 |
| 5.6 Connection to canbus network | 21 |
| 6 Pressure test..... | 22 |
| 7 Check before use..... | 23 |
| 8 Maintenance and cleaning..... | 23 |
| 9 Product disposal | 23 |
| 10 Servicing | 23 |
| 11 Optional equipment..... | 23 |
| 12 Technical specifications..... | 24 |
| 13 Revision history | 24 |

1 General safety instructions

It is very important to strictly follow all the instructions and procedures in the documentation provided with the medical device. The manufacturer can only guarantee safe and reliable use of the medical device if the user, installer or service technician complies with these instructions. The medical device must be installed, repaired and maintained by qualified and certified personnel. The user must have undergone training on the medical device before use. In case of any doubts or inconvenience regarding installation, use and maintenance of the device, you are advised to contact the manufacturer's local representative. **The manufacturer disclaims all responsibility for the improper installation, use and maintenance of the device, including but not limited to:**

- using the device in a way it was not intended to be used
- omitting or disregarding the prescribed maintenance and service intervals
- using and/or installing components that are not original device manufacturer parts
- disregarding the installation and/or user manual
- disregarding any basic safety and precautionary measures listed in the documentation provided
- changing the device and/or interfering with the device, including service and maintenance actions not approved by the manufacturer

The following table shows the most important symbols that the user needs to take into consideration during installation, maintenance and use of the medical device.

| SYMBOL | SYMBOL MEANING |
|---|---|
|  | WARNING: No modification of this equipment is allowed. There is a potential risk of injury or equipment damage if instructions are not followed. Failure to follow these instructions may result in failure of the medical device or personal injury. |
|  | Equipment is not MRI compatible. It's not allowed to install and use it in environment where MRI equipment is used. |
|  | WARNING! 230 V — danger of electric shock and injury. To avoid the risk of electric shock, this equipment must only be connected to a supply mains with protective earth. Supply mains must be interrupted by shutting down the overcurrent protection device (fuse), prior to performing works on any components of electrical system. |
|  | WARNING: Electrostatic sensitive devices — observe handling precautions. Use of this equipment adjacent to or stacked with other equipment should be avoided because it could result in improper operation. If such use is necessary, this equipment and the other equipment should be observed to verify that they are operating properly. Use of accessories, transducers and cables other than those specified or provided by the manufacturer of this equipment could result in increased electromagnetic emissions or decreased electromagnetic immunity of this equipment and result in improper operation. Portable RF communications equipment (including peripherals such as antenna cables and external antennas) should be used no closer than 30 cm (12 inches) to any part of the [ME equipment or ME system], including cables specified by the manufacturer. Otherwise, degradation of the performance of this equipment could result. NOTE: The EMISSIONS characteristics of this equipment make it suitable for use in industrial areas and hospitals (CISPR 11 class A). If it is used in a residential environment (for which CISPR 11 class B is normally required) this equipment might not offer adequate protection to radio-frequency communication services. The user might need to take mitigation measures, such as relocating or re-originating the equipment. |
|  | May cause or intensify fire. Oxidiser. |
|  | No smoking. |
|  | The use of any form of lubricant or grease during installation and service is strictly prohibited. Only use approved lubricants — oxygen fat may be used if it is adapted to an oxygen environment (e.g. GLEITMO 595/599). |
|  | Contains gas under pressure. May explode when heated. |
|  | Product should not be disposed of with household waste. |
|  | Product is marked with CE according to Directive 93/42/EEC on Medical Devices (MDD), Annex II excluding (4) |

2 Product types and symbols

This document refers to all types listed in the following table. The manufacturer reserves the right to supplement this document with possible additions by using annexes. This may be necessary in, but not limited to, the following cases:

- Individual product derivatives which do not affect intended use (i.e. upon customer request)
- To comply with local and/or national regulations

LIST OF ALL MODELS AND TYPES







CCB
CCB with alarm
CCB with reserve
CCB with reserve and alarm
Shut-off box

There are different types of Control closing boxes. All types can be surface or sunken mounted.

- **CCB** is a Control closing box, which is used for monitoring and controlling the status of medical gases that are led through the CCB. A single CCB can be used to control up to 6 different medical gases.
- **CCB with alarm** is a Control closing box, which is used for monitoring and controlling the status of medical gases that are led through the CCB with alarm. A single CCB with alarm can be used to control up to 6 different medical gases. Monitoring system with alarm is available to provide additional information on the status of individual medical gas.
- **CCB with reserve** is a Control closing box, which is used for monitoring and controlling the status of medical gases that are led through the CCB with reserve. A single CCB with reserve can be used to control up to 3 different medical gases.
- **CCB with reserve and alarm** is a Control closing box, which is used for monitoring and controlling the status of medical gases that are led through the CCB with alarm and reserve. A single CCB with alarm and reserve can be used to control up to 3 different medical gases. Monitoring system with alarm is available to provide additional information on the status of individual medical gas.
- **SHUT-OFF BOX** is a box, which is used to control medical gases, that are led through the box. A single Shut-off box can be used to control up to 6 different medical gases. Additionally, shut off box can be equipped with pressure manometers, to also enable monitoring of the individual gas status.

In some CCB versions optional equipment can be installed:

- Flow sensor
- Reed contact on shut-off valves
- Reed contact on door lock
- Modbus converter
- 4-20mA duplicator card

| SYMBOL | SYMBOL MEANING | SYMBOL | SYMBOL MEANING |
|---|---------------------------------|---|---------------------------|
|  | Shut-off valve |  | Pressure transmitter |
|  | Terminal unit (emergency inlet) |  | Contact pressure gauge |
|  | Flow sensor |  | Pressure switch low alarm |
|  | Pressure gauge | | |

2.1 Labelling

2.1.1 CCB label

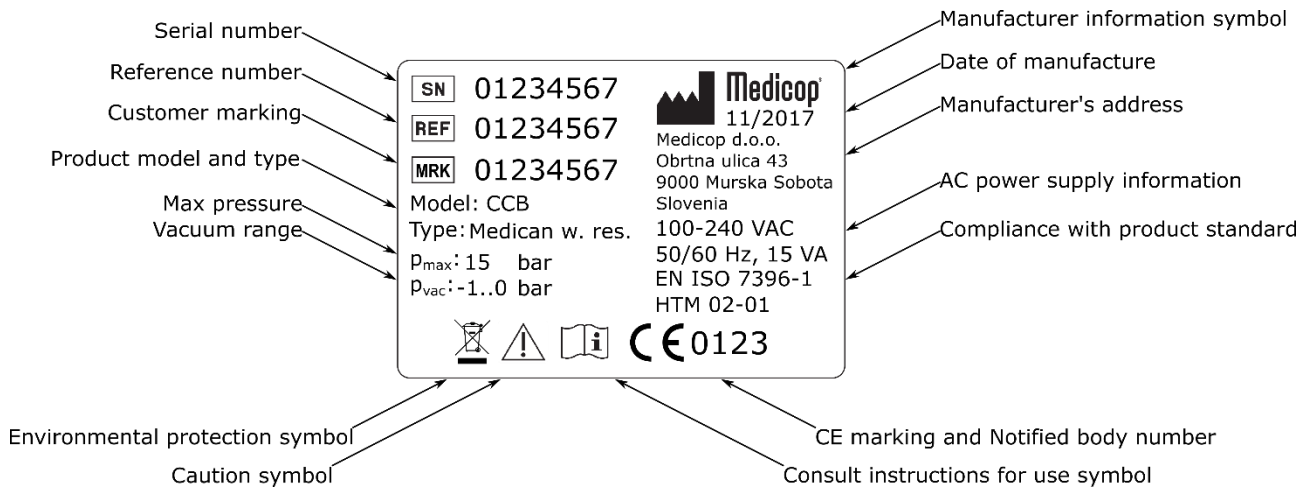

2.1.2 Shut-off box label

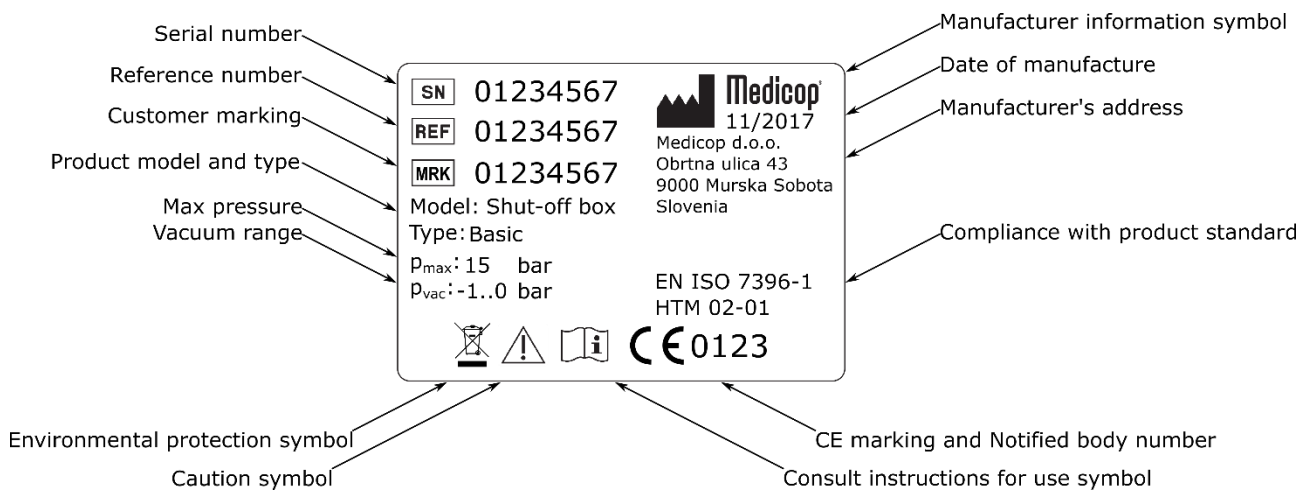

Data used is of informative purpose

3 Schematic overview (P&ID)

3.1 CCB 1-5 gases (available options)

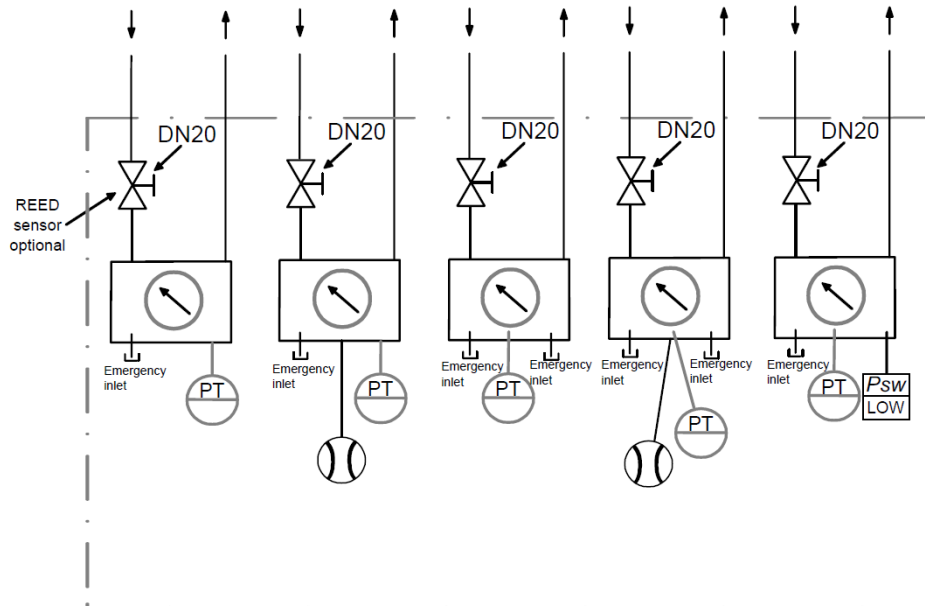

3.2 CCB with reserve (available options)

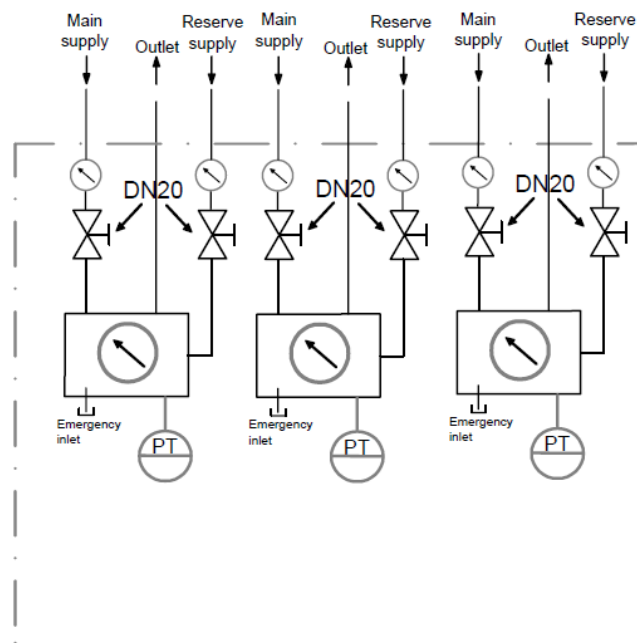

3.3 CCB 6 gases (Gasmon3 alarm)

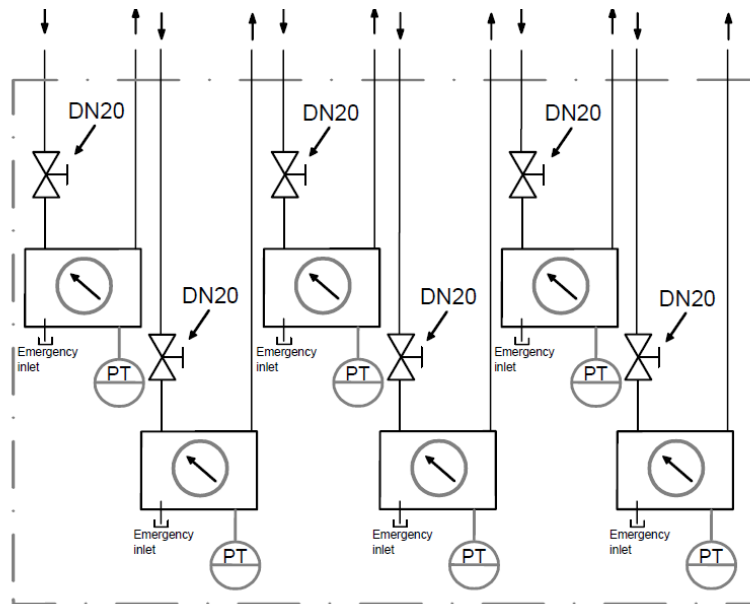

3.4 CCB with contact gauges (Gasmon3 alarm)

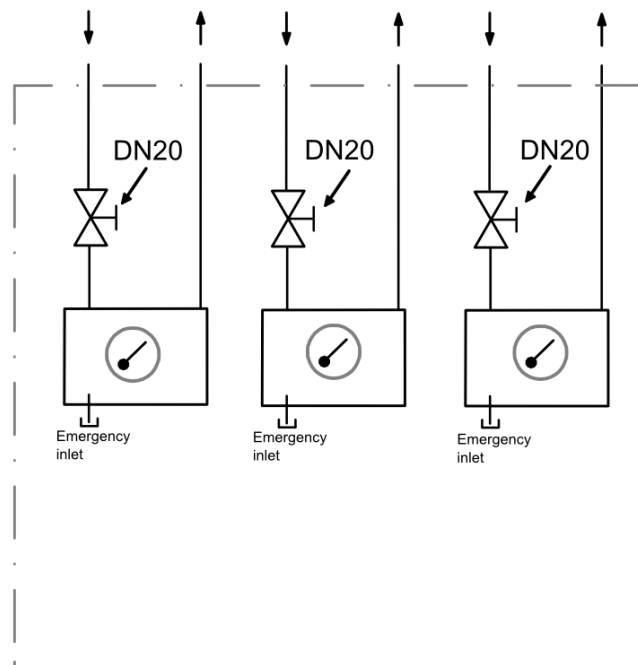

3.5 SHUT-OFF box

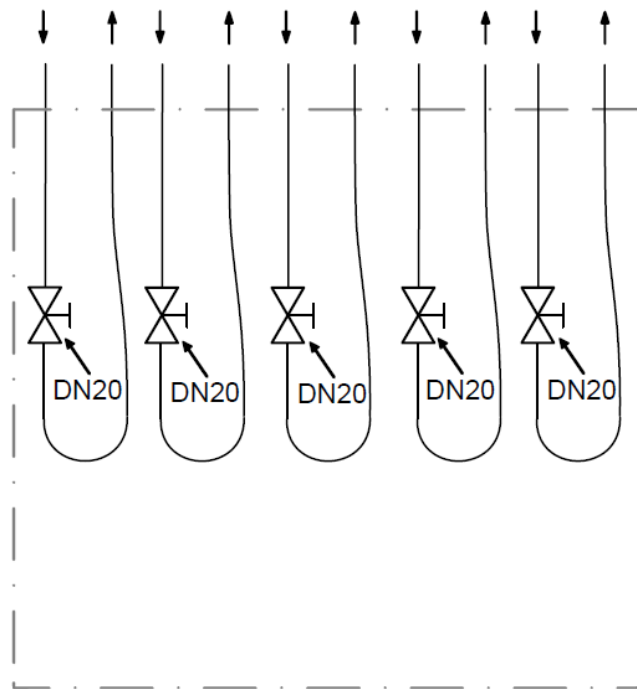

3.6 SHUT-OFF box with pressure gauge

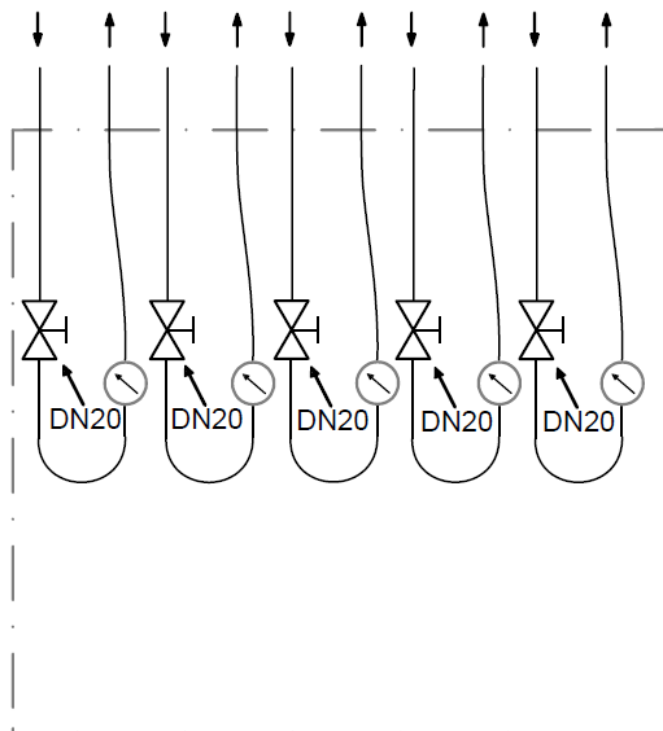

4 Installation and connection of components

4.1 Sunken mounted box measurements

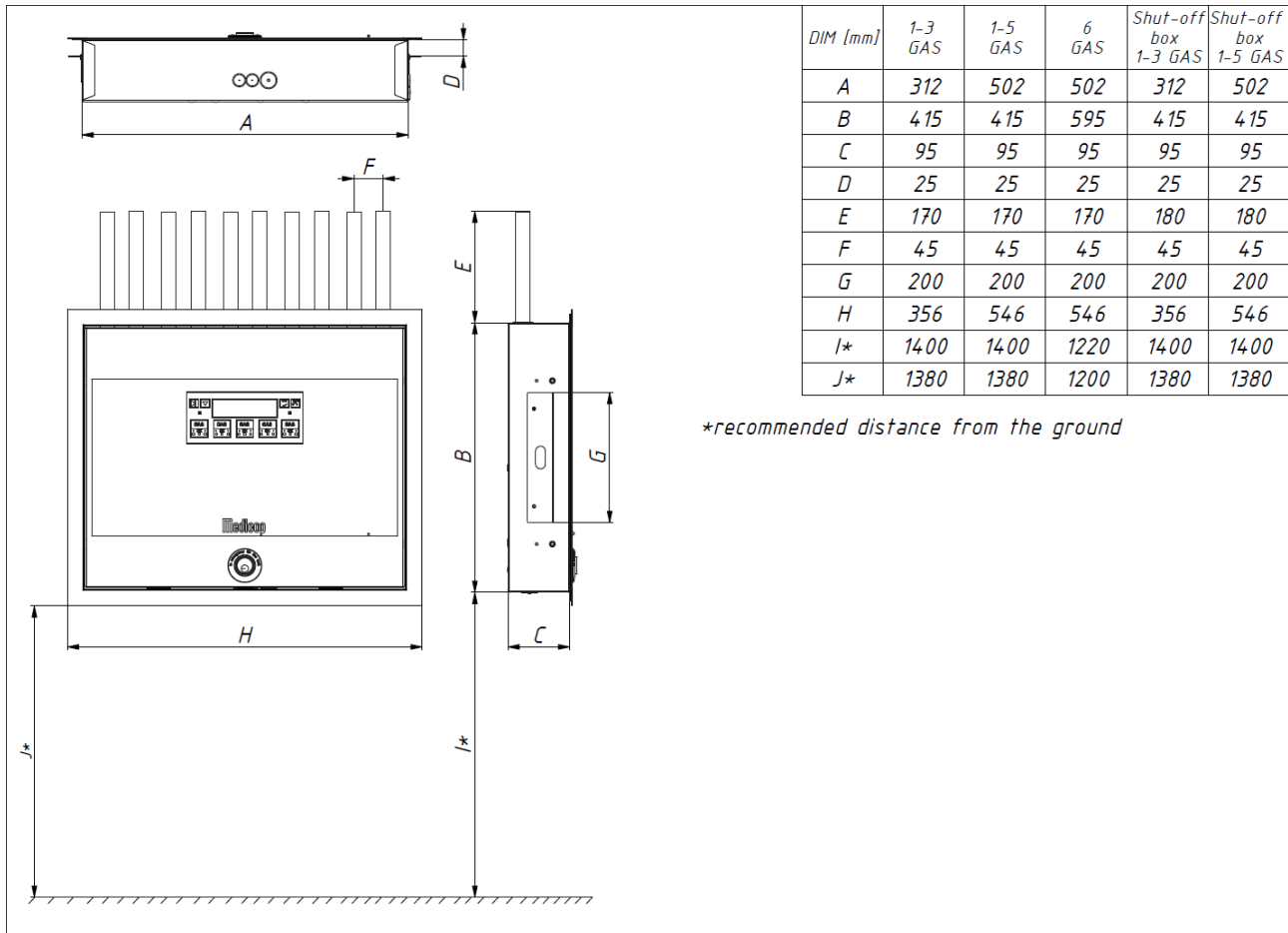

All dimensions are in millimeters!

4.2 Surface mounted box measurements

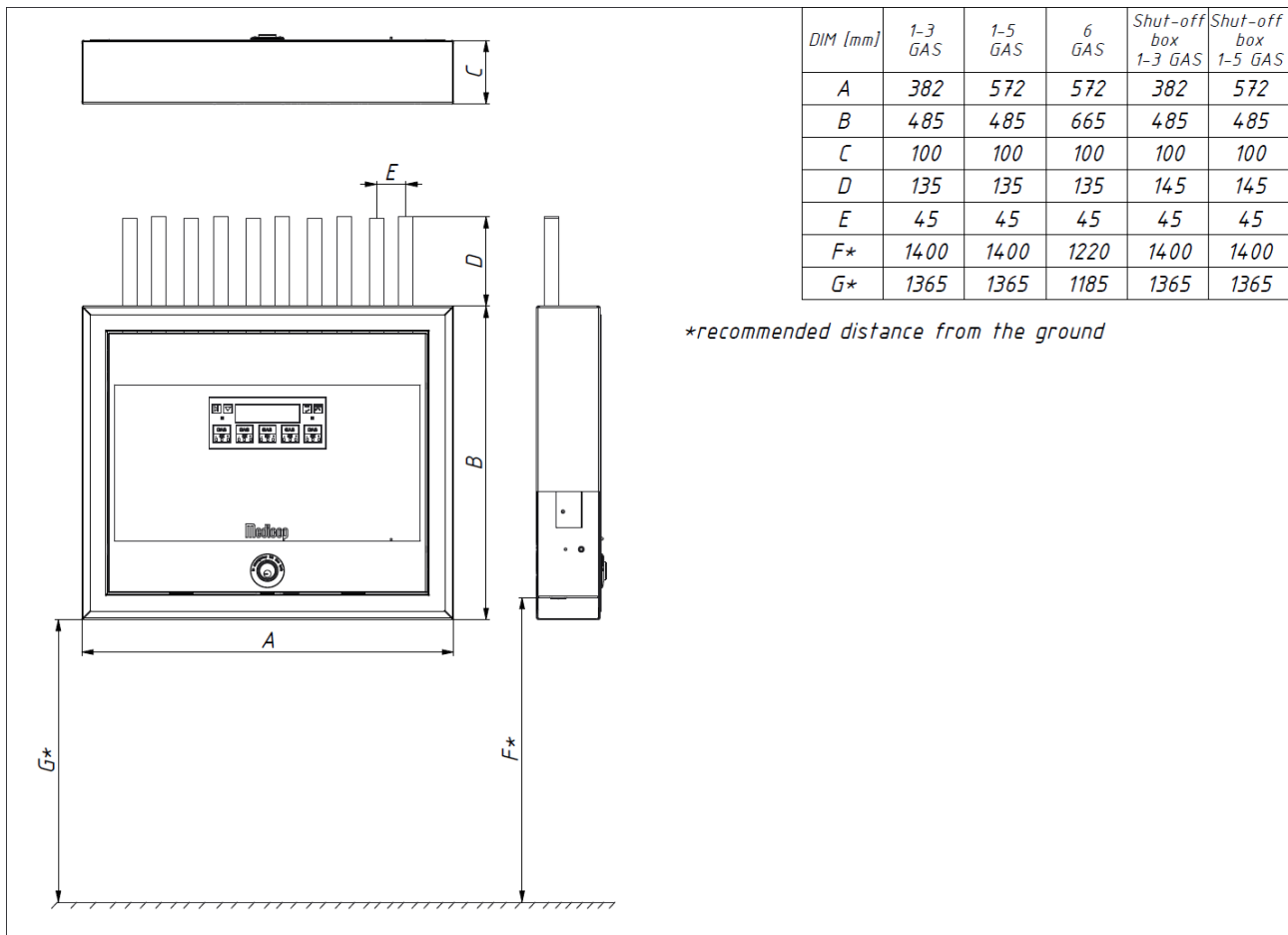

All dimensions are in millimeters!

4.3 Box installation

| STEP | DESCRIPTION |
|------|---|
| ! | Dimensions for different type of installations you find in above tables. |
| 1 | First install the box with blocks and pipes into wall (sunken mounted) or on the wall (surface mounted). |
| 2 | Use added bracket parts (for bricks wall use additionally plaster for temporary fixation) and holes for fixation. |

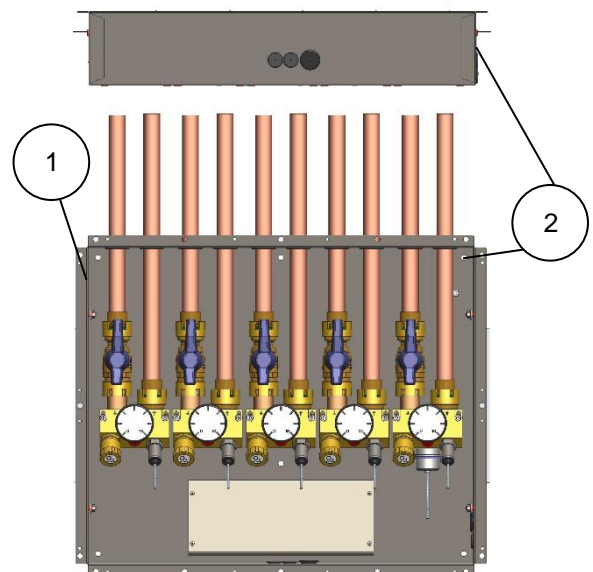

4.4 Pipe soldering

| STEP | DESCRIPTION |
|------|--|
| ! | Pipes need to be soldered according to ISO 7396-1! |
| 1 | Disconnect pipes from the block with the special key (it is added to the shipment) to prevent shield gas flow. |
| 2 | Loose fixation screws of the block and move block down. |

| | |
|---|--|
| ! | <p>The block (2) can be moved up or down if screws are released.</p> <p>At installation and operation, block must be on upper position and nuts on inlet and outlet pipe must be tightened.</p> <p>To insert red or green coins for pressure test and pipe soldering, block can be moved down.</p> |
|---|--|

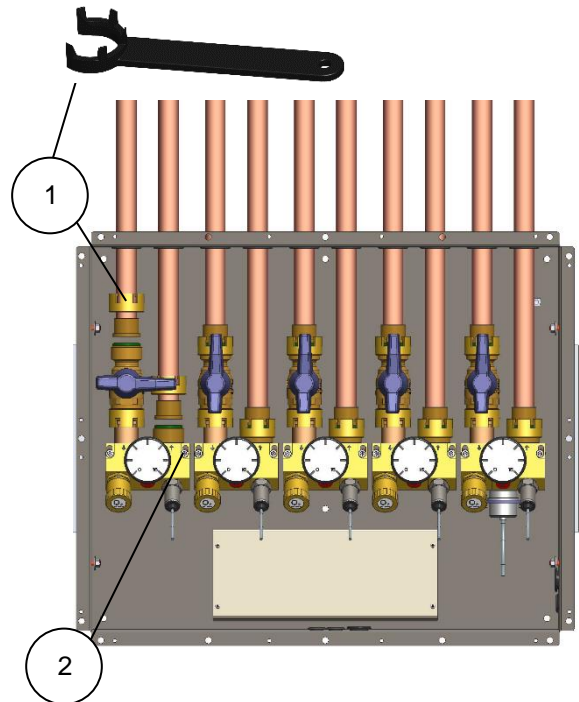

4.5 Door frame

| STEP | DESCRIPTION |
|------|--|
| 1 | The door frame with the door. |
| 2 | Fastening nuts. |
| ! | <p>The frame has 4 slotted holes to place frame into the box of CCB. 4 fastening nuts are used to secure the door frame.</p> <p>For electrical connection read chapter ELECTRICAL CONNECTIONS.</p> |

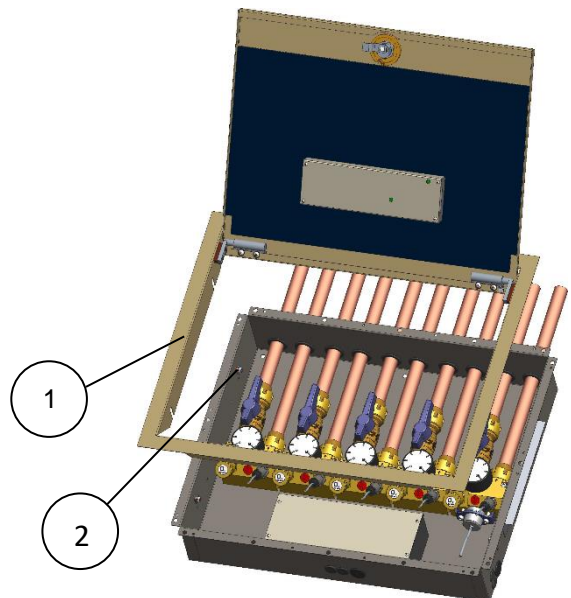

4.6 Surface mounted Medican slave alarm

In the surface casing there are 4 holes (marked on figure) which serve as mounting holes for fixing the Medican alarm casing to the wall. It is the same casing for glass and plastic front plate.

| POS. | DIMENSIONS FOR SINGLE CASING [mm] | DIMENSIONS FOR DOUBLE CASING [mm] |
|------|-----------------------------------|-----------------------------------|
| A | 275 | 275 |
| B | 130 | 210 |
| C | 80 | 80 |

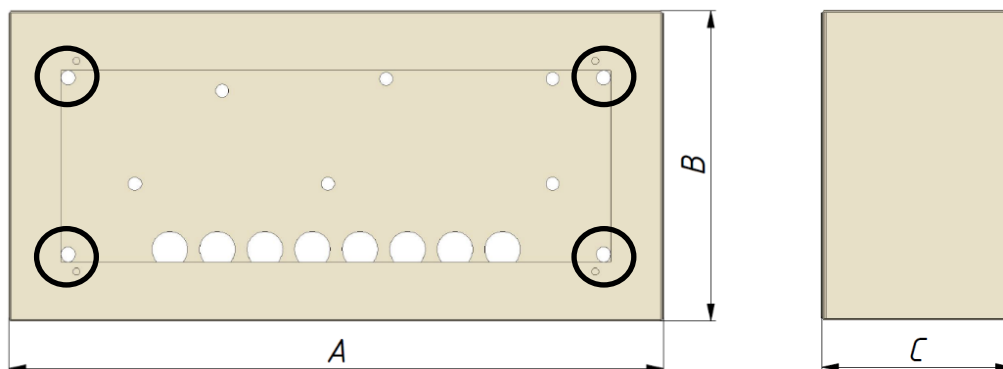

4.7 Sunken mounted Medican slave alarm

On side of the sunken mounting casing, there are holes for fixing the casing into the wall (marked on figure). If you install into the drywall there need to be prepared beam on the left and right side (e.g. wood or steel profile) where you fix in the screws.

| POS. | DIMENSIONS FOR SINGLE CASING PLASTIC COVER [mm] | DIMENSIONS FOR SINGLE CASING GLASS COVER [mm] | DIMENSIONS FOR DOUBLE CASING GLASS COVER [mm] |
|------|---|---|---|
| A | 240 | 250 | 250 |
| B | 110 | 115 | 195 |
| C | 230 | 237,5 | 237,5 |
| D | 100 | 100 | 180 |
| E | 70 | 70 | 80 |

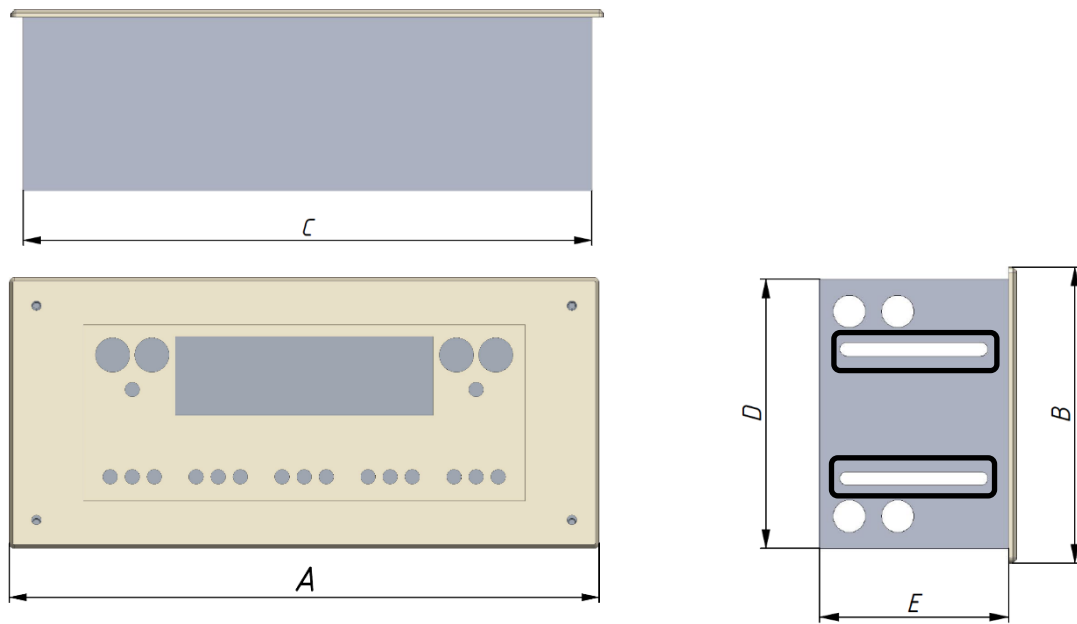

4.8 Surface mounted Gasmon3 slave alarm

In the surface casing there are 4 holes (marked on figure) which serve as mounting holes for fixing the Gasmon3 alarm casing to the wall.

| POS. | DIMENSIONS FOR SINGLE CASING [mm] | DIMENSIONS FOR DOUBLE CASING [mm] |
|------|--------------------------------------|--------------------------------------|
| A | 185 | 185 |
| B | 95 | 165 |
| C | 70 | 70 |

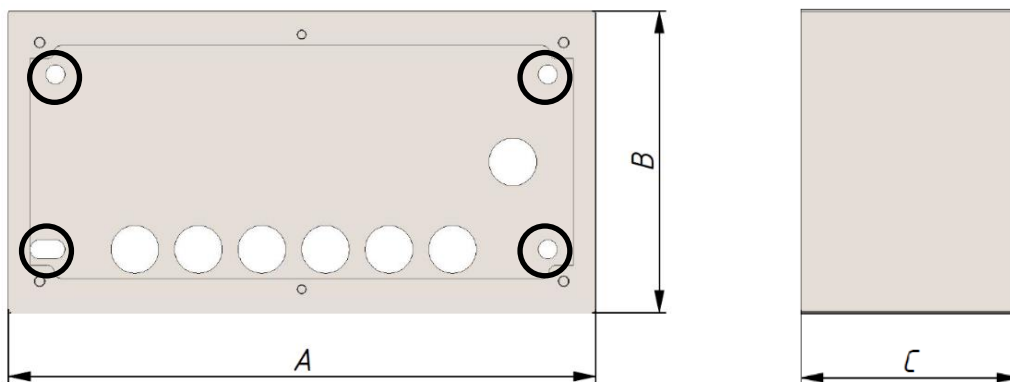

4.9 Sunken mounted Gasmon3 slave alarm

On side of the sunken mounting casing, there are holes for fixing the casing into the wall (marked on figure). If you install into the drywall there need to be prepared beam on the left and right side (e.g. wood or steel profile) where you fix in the screws.

| POS. | DIMENSIONS FOR SINGLE CASING [mm] | DIMENSIONS FOR DOUBLE CASING [mm] |
|------|-----------------------------------|-----------------------------------|
| A | 185 | 185 |
| B | 95 | 165 |
| C | 177 | 177 |
| D | 87 | 157 |
| E | 70 | 70 |

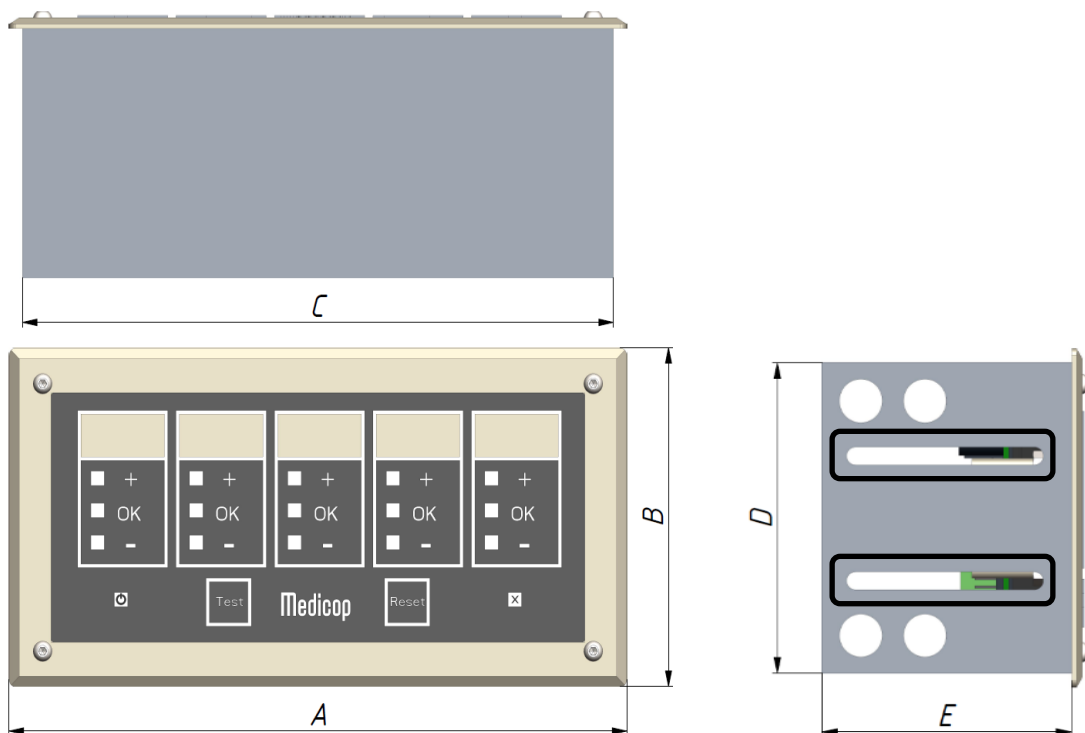

5 Electrical connection

5.1 Connection to the mains supply

| STEP | DESCRIPTION |
|------|---|
| 1 | Connect grounding wire from casing to the door frame. |
| 2 | Connect flat data cable to supply module. Connect CAN-link cable to supply module. |
| 3 | Connect grounding from main supply to fast-on connector. Connect main supply, use added connector. |

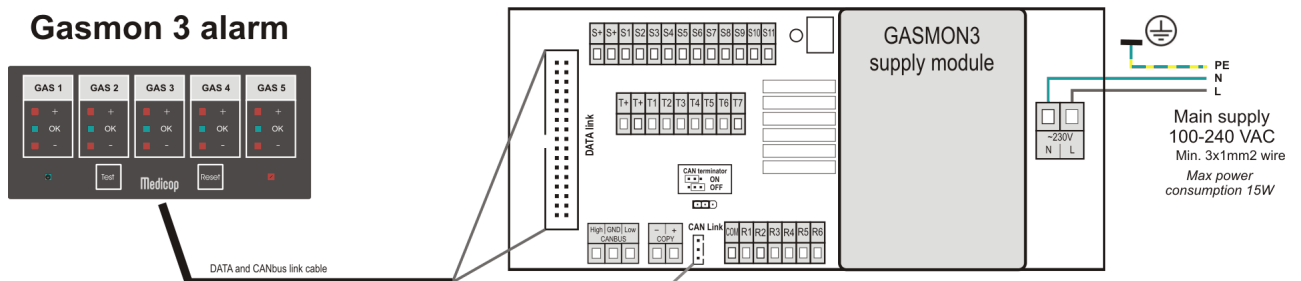
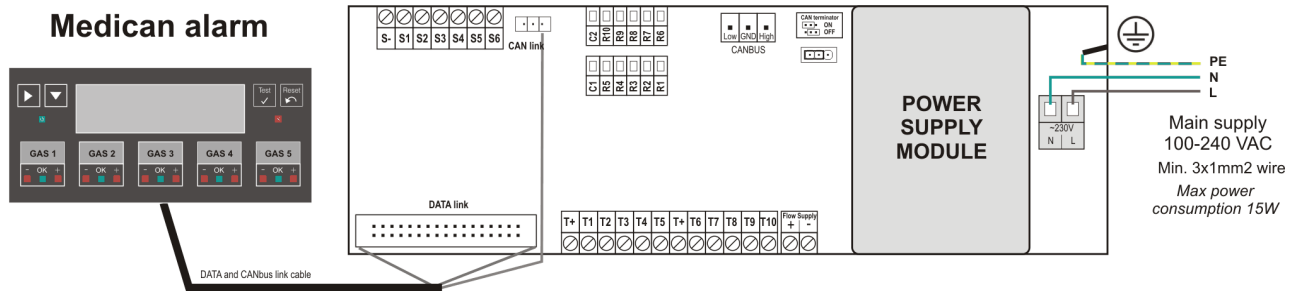
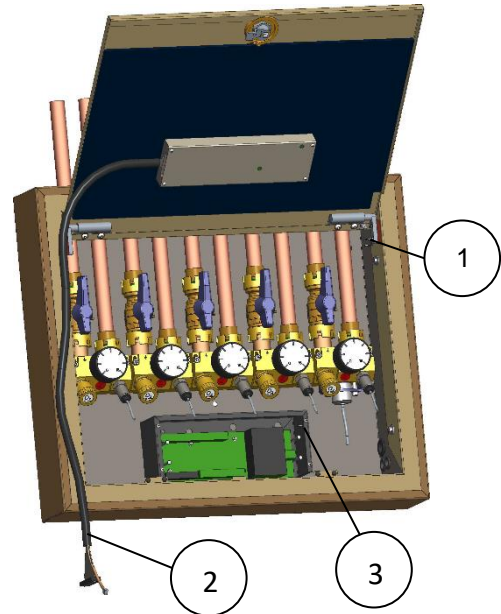

5.2 Wiring example with all options for Medican alarm

For specific information about connections, alarm configuration and potential free contacts, see software information form which is added to each delivery!

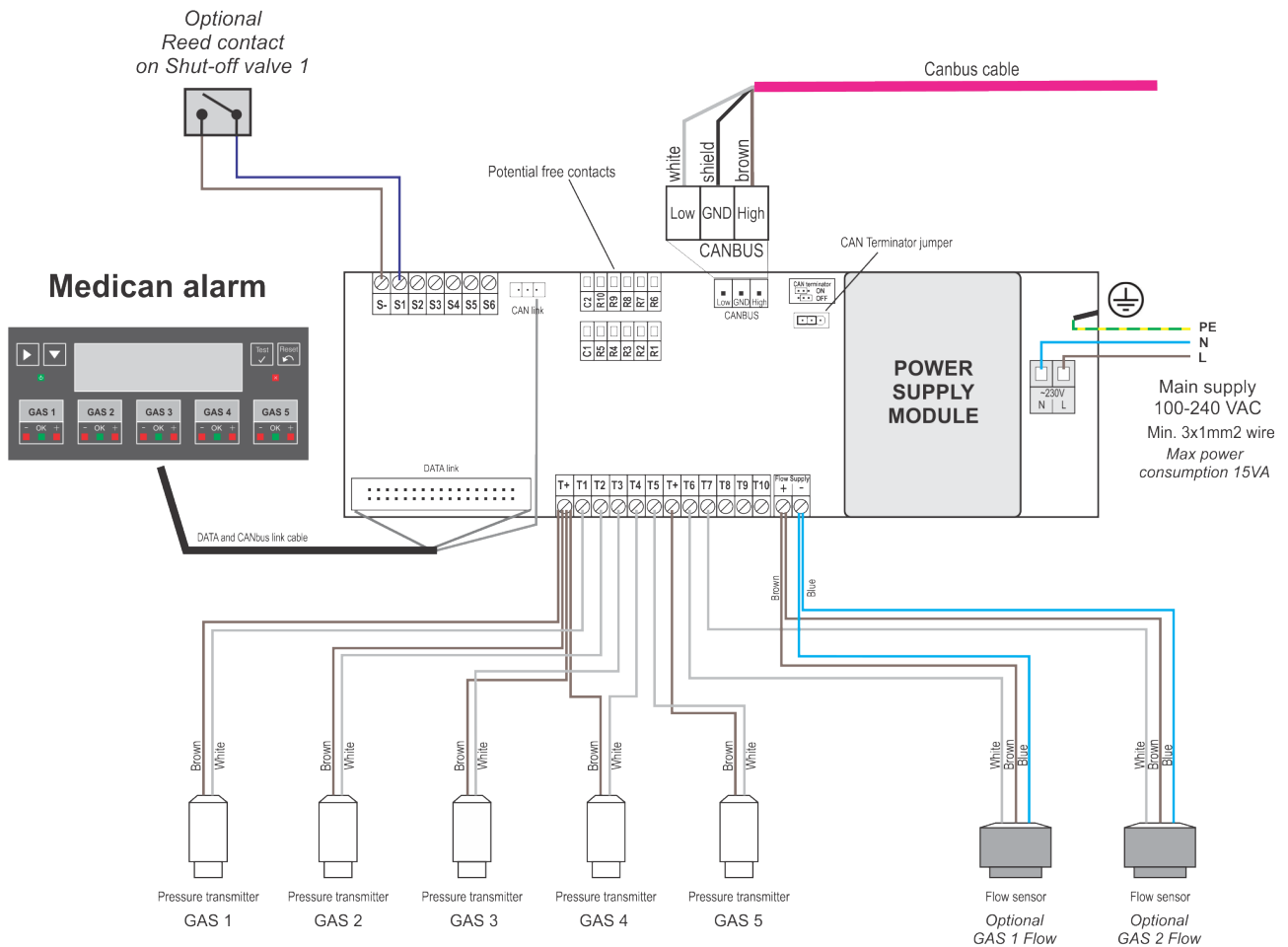

Potential free contacts - details

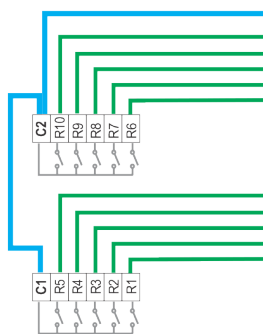

closed - pressure OK
open - pressure HIGH or LOW

Potential free contacts - default:

- R1 – GAS 1 High
- R2 – GAS 1 Low
- R3 – GAS 2 High
- R4 – GAS 2 Low
- R5 – GAS 3 High
- C1 – (COMMON CONTACT)
- R6 – GAS 3 Low
- R7 – GAS 4 High
- R8 – GAS 4 Low
- R9 – GAS 5 High (or System fault alarm)
- R10 – General alarm (or GAS 5 Low)
- C2 – (COMMON CONTACT)

Contact between COMMON and R1, R2, R3,... is closed when there is NO ALARM.
Maximum voltage on potential free contact is 50V.
Maximum current on all relays together is 1A resistive load.

5.3 Wiring example with all options for Gasmon3 alarm

For specific information about connections, alarm configuration and potential free contacts, see software information form which is added to each delivery!

CCB with Gasmon 3 CG
(contact gauges)

- S+ - Common
- S+ - Common
- S1 - Contact pressure gauge GAS 1 High
- S2 - Contact pressure gauge GAS 1 Low
- S3 - Contact pressure gauge GAS 2 High
- S4 - Contact pressure gauge GAS 2 Low
- S5 - Contact pressure gauge GAS 3 High
- S6 - Contact pressure gauge GAS 3 Low

CCB with Gasmon3
(pressure transmitters)

- T+ - Common (+ supply to transmitter)
- T+ - Common (+ supply to transmitter)
- T1 - Pressure transmitter GAS 1
- T2 - Pressure transmitter GAS 2
- T3 - Pressure transmitter GAS 3
- T4 - Pressure transmitter GAS 4
- T5 - Pressure transmitter GAS 5
- T6 - Pressure transmitter GAS 6

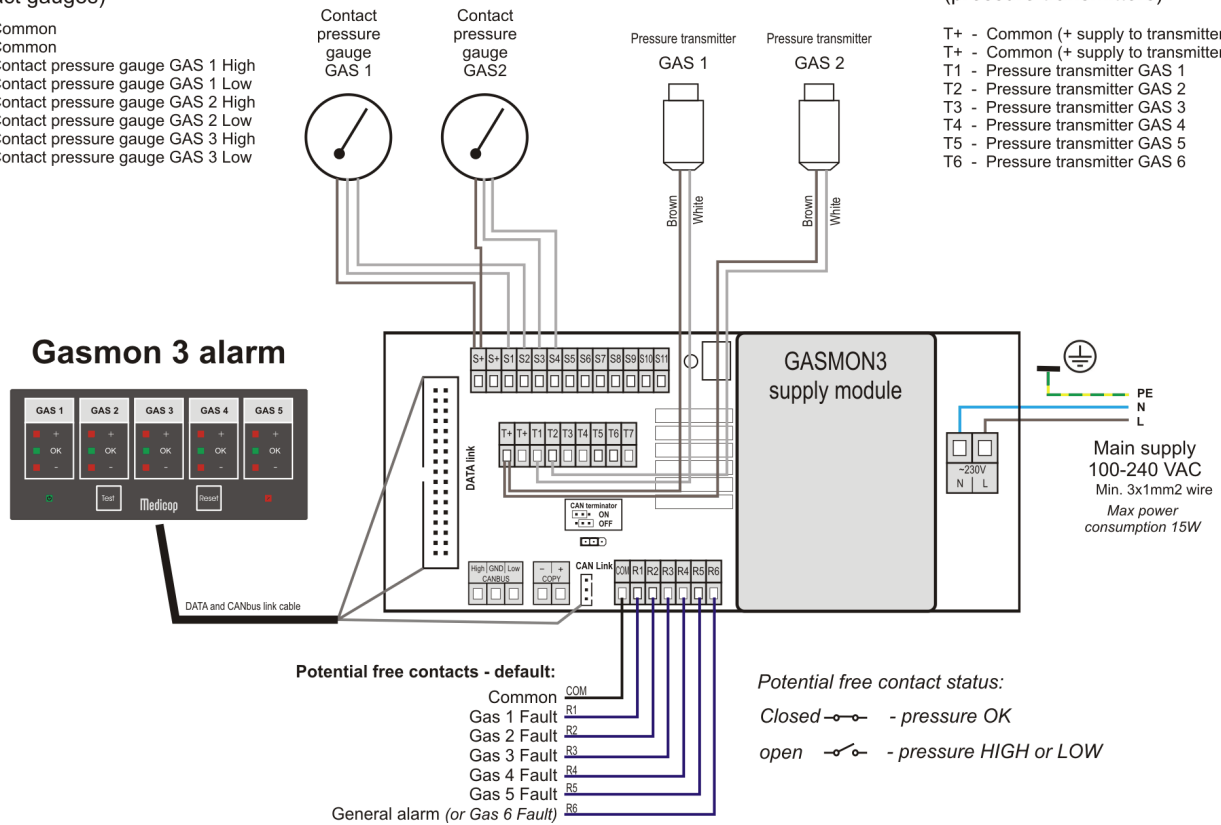

5.4 Connection with Medican slave alarm

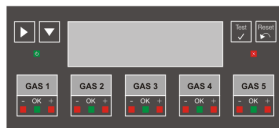
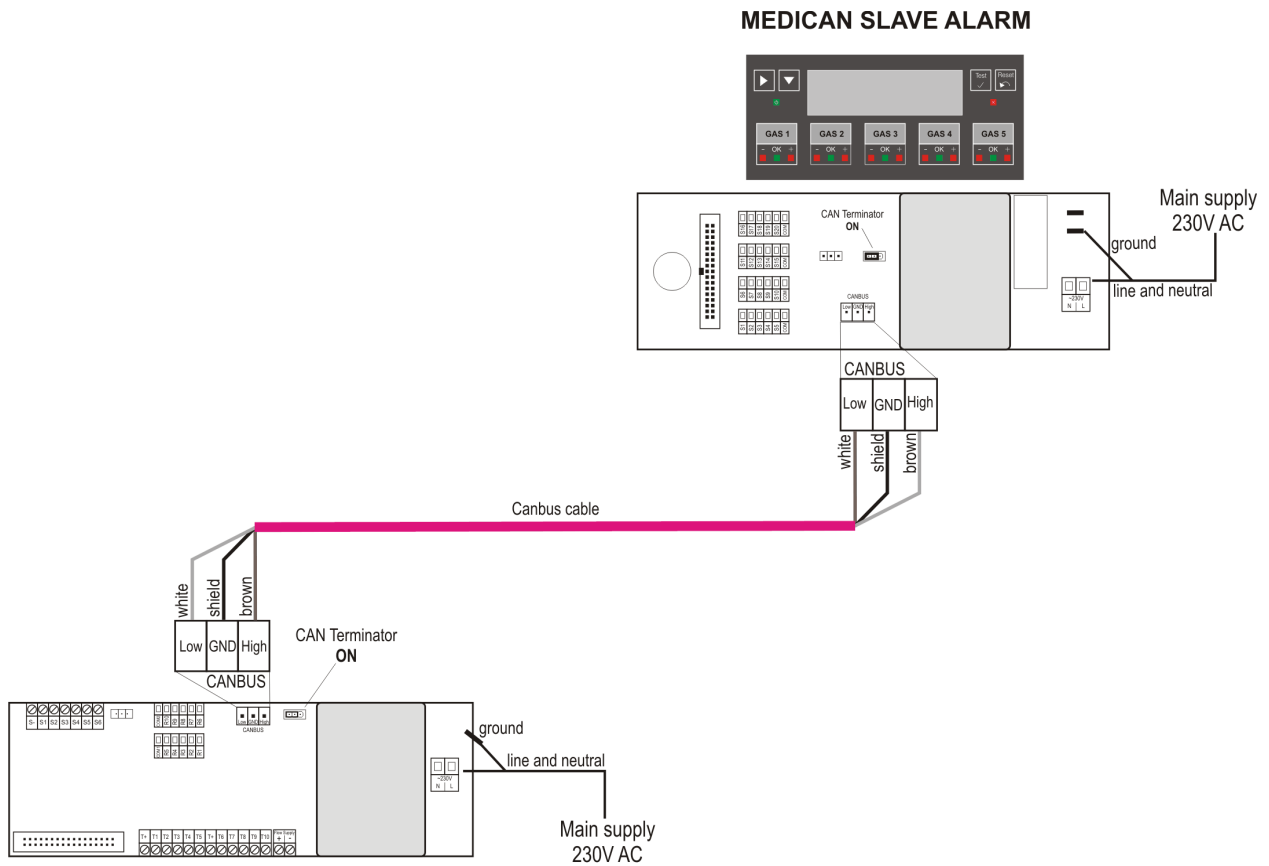

MEDICAN ALARM

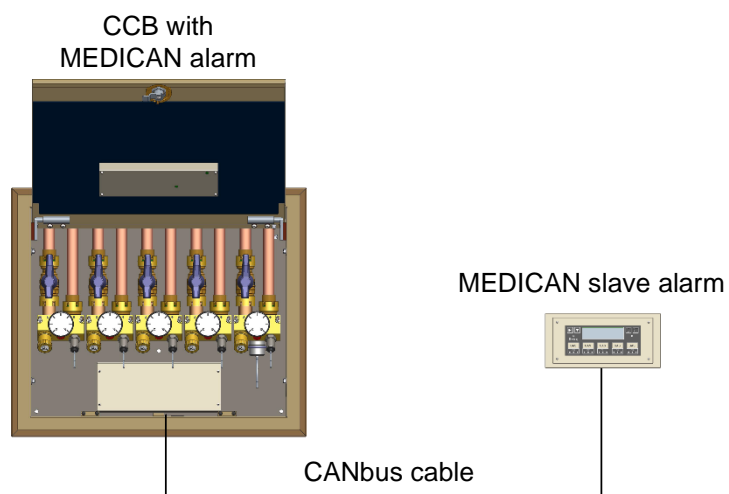

5.5 Connection with Gasmon3 slave alarm

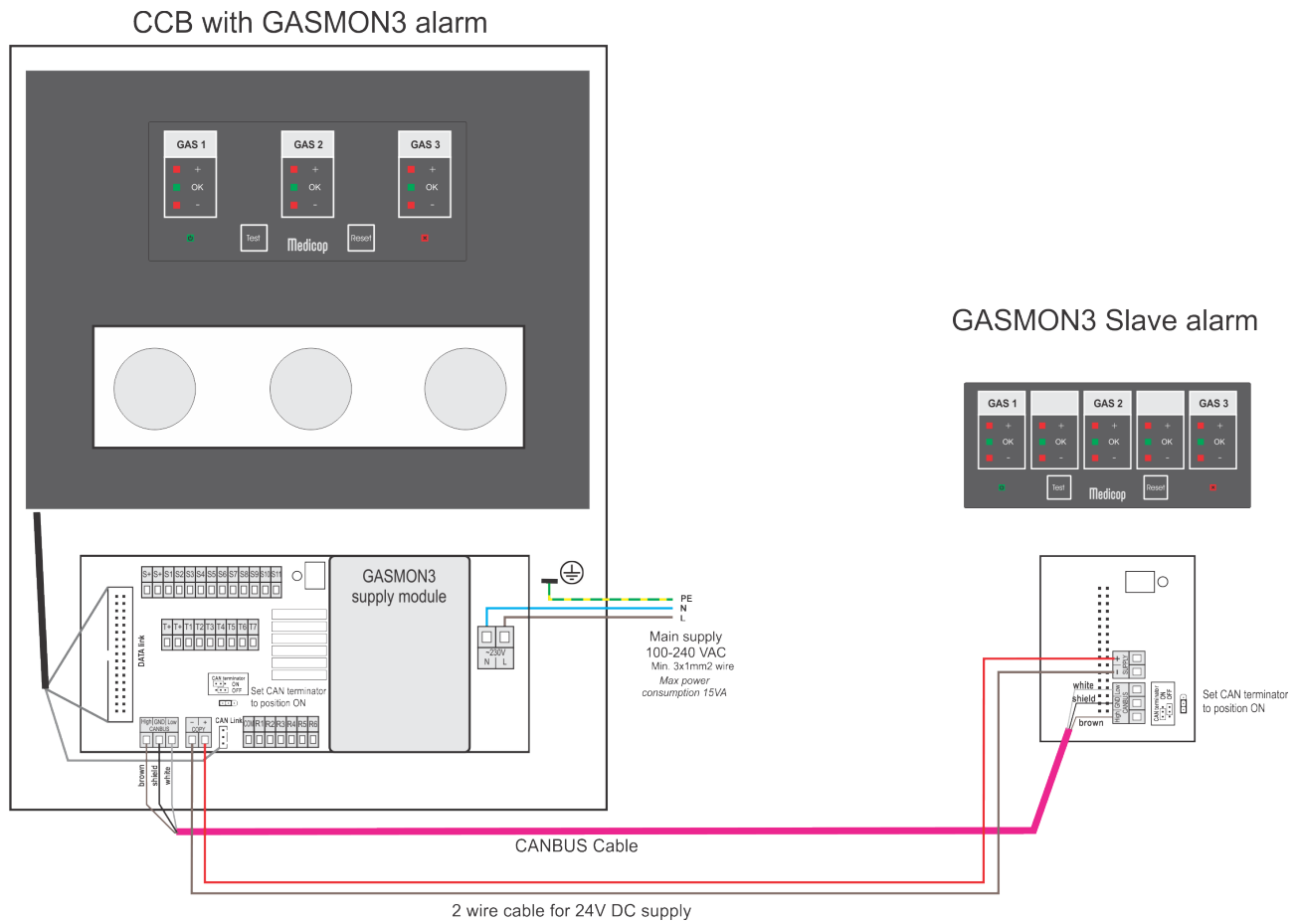

Up to 3 Gasmon3 slave alarms can be connected to one Gasmon3 alarm with main (230VAC) power supply board.
In case that more than 3 slave alarm are connected, every fourth must be with main (230VAC) power supply board.

5.6 Connection to canbus network

| STEP | DESCRIPTION |
|------|--|
| 1 | <p>All types of Medican and Gasmon3 alarms can be connected together into CANBUS network. This type of connection requires cable that is specified for CANBUS data transfer. Different manufacturer example:</p> <ul style="list-style-type: none"> - NORTHWIRE FJ1939202 – 001 max. length 300 m - LAPP CABLE UNITRONIC BUS CAN UL/CSA 1x2x0,22 max. length 100 m - NETBUS CAN Y122 for 100 m - NETBUS CAN Y175 for 300 m <p>Other cables are possible, but they have to meet following specifications:</p> <ul style="list-style-type: none"> - Twisted pair with shield. - Conductor cross-section: <ul style="list-style-type: none"> for distance up to 100 m – around 0.25 mm², for distance up to 250 m – around 0.34 mm², for distance up to 300 m – around 0.5 mm². - Characteristic Impedance @ 1 MHz: 120 Ohms (min. 108, max. 132). - Specific line delay: Vp more that 65 % and less than 5 ns/m. - Capacitance between conductors: 40 pF/m (less than 70 pF/m). - Capacitance conductor to shield: 70 pF/m (less than 110 pF/m). <p>Color of the CAN cable varies by manufacturer. Equally coloured cables must be connected to all alarms; inlet LOW (COLOR 1) and inlet HIGH (COLOR 2).</p> |

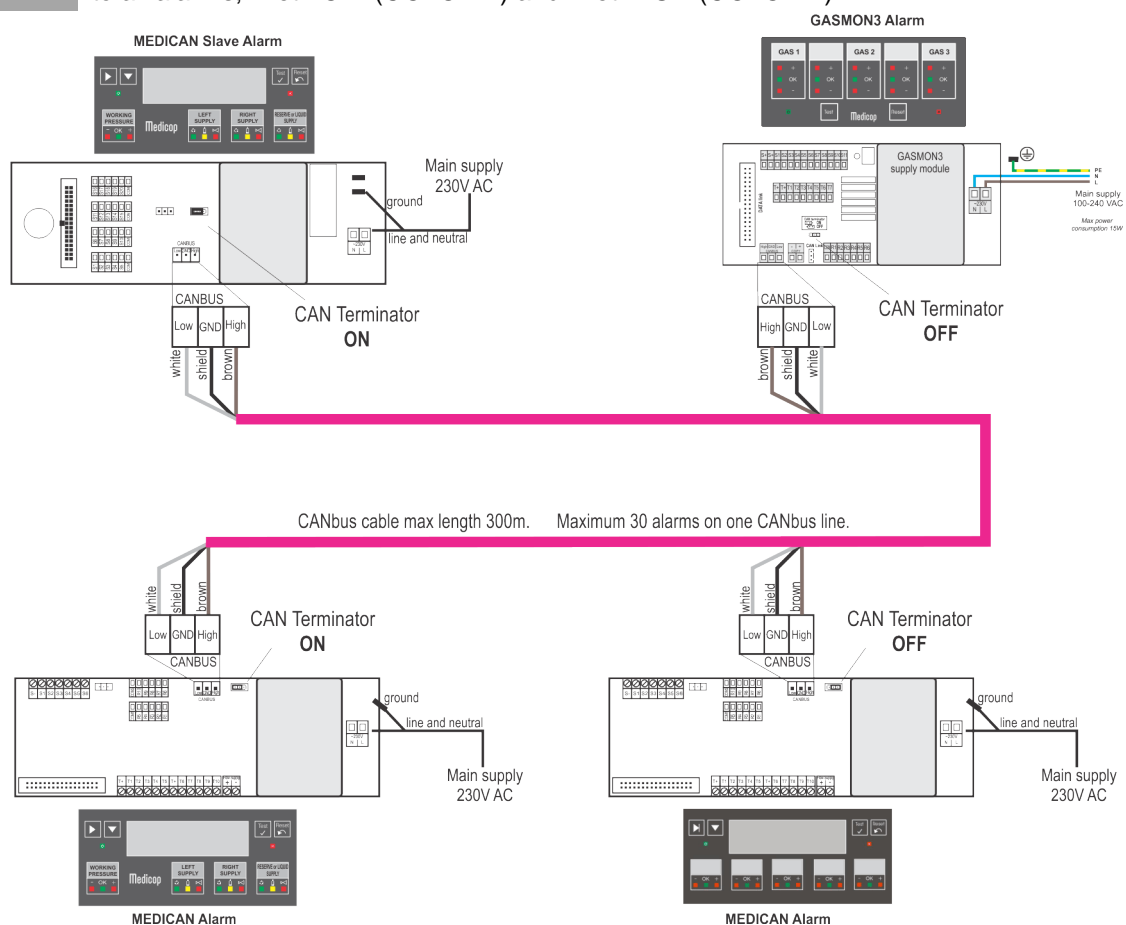

CANBUS SWITCH can be used for networks with big distances any many CANbus lines. One switch can join up to 4 CANbus lines in one big network. Many CAN switches can be used at the same time in one complex network.

6 Pressure test

Prior to regular operation of the CCB it is necessary to carry out the pressure testing of the inlet and outlet branch of the block. Enclosed in the casing of CCB are red coins for pressure testing. During normal operation green coins are used. Green coin is evident through special nut (1).



Maximum test pressure for CCB is 15 bar for all gases except vacuum.

Do not over pressure vacuum gauge.

Maximum pressure for vacuum transmitters is 5 bar.

| TEST | PROCEDURE |
|--|--|
| Installation upstream from the CCB block | <p>Unscrew all the nuts (1) on the inlet and outlet branch of the block.</p> <p>Unscrew bolts (2) by which the block is fixed to the casing of CCB.</p> <p>Lower the block to remove the green coin from the seat of the shut-off valve.</p> <p>Replace the green coin with the red coin.</p> <p>Screw the nuts back on and tighten them.</p> <p>By applying the pressure to the system, the inlet branch, upstream from the block is pressure-tested.</p> |
| Installation downstream from the CCB block | <p>When pressure testing the outlet branch, downstream from the block, it is also necessary to unscrew the nuts (1) and bolts (2), and lower the block, so that the green coin can be replaced by the red coin.</p> <p>Nuts and bolts must be put back and re-tightened. By applying pressure to the system, the gas installation, downstream from the block, can be checked for possible leakages.</p> |
| TEST | PROCEDURE |
| CCB block | <p>This testing procedure is being used for repairs and maintenance checks. In this case both green coins are replaced by the red one. This way block leak tightness of the CCB can be tested. Pre-test has already been carried out by the manufacturer.</p> |

GREEN COIN

RED COIN

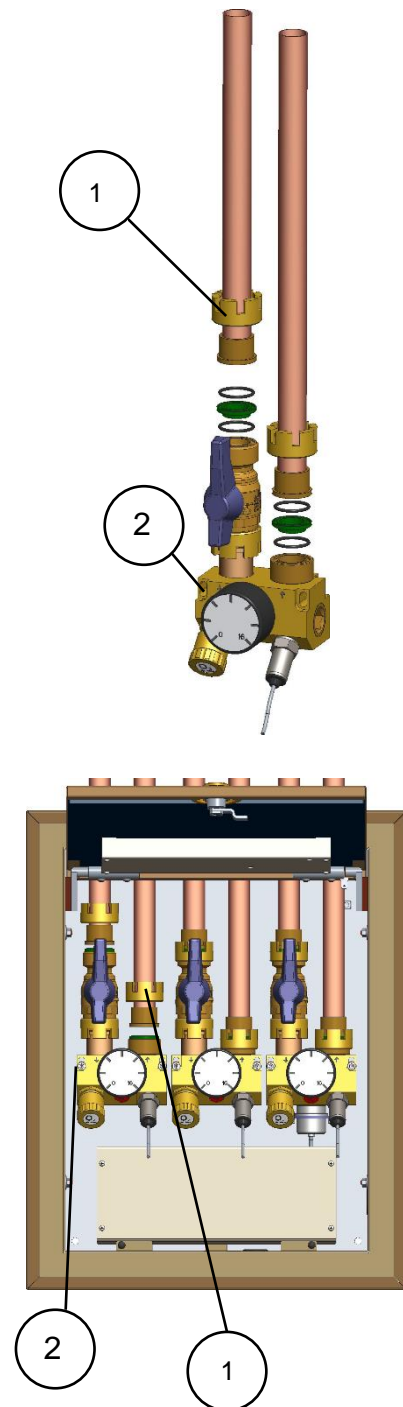

7 Check before use

| STEP | COMPONENT | PROCEDURE |
|------|-----------------|---|
| 1 | Shut-off valves | Check if all shut-off valves are in right position. |
| 2 | All connections | Check all connection for possible leakage. |
| 3 | Alarm display | Check all buttons, led lights, menus on display. Compare pressure on manometers and value on display. |

8 Maintenance and cleaning

- For cleaning use only fat free cloths.
- Do not use solvents or flammable materials to clean.
- Electrical connections must not come into contact with moisture.
- External surfaces and front panel of alarm display can be cleaned with damp cloths.
- Interior surfaces of CCB can be cleaned with damp cloths.
- For electrical connections and back side of alarm display use dry cloths.

9 Product disposal

If the device is no longer in use, it should be properly disposed of to ensure local environmental protection regulations are met. The device does not contain any toxic or radioactive elements that could adversely affect the disposal site. The device itself and its components are not biodegradable in any way. If possible, base materials recycling is recommended.

Contact your local authority for the proper disposal method.

| MATERIAL | COMPONENT |
|----------|--|
| Steel | Base housing, door frame and door |
| Copper | Gas tubes and wires |
| Brass | CCB block and pipeline fittings |
| Plastic | Handles on shut-off valves, housing of the door lock |
| Glass | Electronics front panel on the door |

Note: Detailed material documentation is available upon request.

10 Servicing

The facility owner is responsible for the necessary service and maintenance on the equipment. All service procedures must be performed by qualified personnel authorized by the manufacturer. Contact your local distributor for information about service intervals and procedures.

11 Optional equipment

Read separate manuals for optional equipment like Flow sensor, Modbus converter, 4-20mA duplicator card.

12 Technical specifications

| | CCB Medican | CCB with reserve Medican | CCB Gasmon3 | CCB Gasmon3 and contact gauges | SHUT – OFF BOX |
|---|--|---------------------------------|---------------------------------|-----------------------------------|---------------------------------|
| Max pressure [bar] Vacuum range -1...0 [bar] | 15 bar | 15 bar | 15 bar | 15 bar | 15 bar |
| Power supply [V] | 100-240 VAC 50/60 Hz | 100-240 VAC 50/60 Hz | 100-240 VAC 50/60 Hz | 100-240 VAC 50/60 Hz | x |
| Power consumption [VA] | 15 | 15 | 15 | 15 | x |
| External circuit breaker [A] | 10 | 10 | 10 | 10 | |
| Operating temperature [°C] | -20 to +50 | | | | |
| Relative humidity | 5 - 95% non condensing | | | | |
| Degree of protection (IP rating) | IP52 | | | | |
| Atmospheric pressure range [kPa] | 70 - 106 | | | | |
| Ideal storage conditions | Temperature 15 – 27°C, Humidity 30 – 60% | | | | |
| Alarm | Medican or no alarm | Medican or no alarm | Gasmon3 or no alarm | Gasmon3 or no alarm | x |
| Transmitters | 10 | 10 | 7 | x | x |
| Potential free contacts | 10 | 10 | 6 | 6 | x |
| *Flow sensors | 5 | 5 | x | x | x |
| *Contacts like pressure switch or contact gauge | 6 | 6 | x | 11 | x |
| *Reed contact on shut-off valves | • | • | x | x | x |
| *Reed contact on door lock | • | • | x | x | x |
| *Modbus converter | • | • | x | x | x |
| *4-20mA duplicator card | • | • | x | x | x |
| *External alarm | • | • | • | • | x |
| Weight [kg] | 9-25 | 14-21 | 9-28 | 9-28 | 7-15 |
| Dimensions 1 – 3 gases sunken mounted (WxHxD) | 356x456x97 (4 from the wall) | 546x456x97 (4 from the wall) | 356x456x97 (4 from the wall) | 356x456x110 (12 from the wall) | 356x456x97 (4 from the wall) |
| Dimension 1 – 3 gases surface mounted (WxHxD) | 382x482x100 | 572x482x100 | 382x482x100 | 382x482x110 | 382x482x100 |
| Dimensions 4 – 5 gases sunken mounted (WxHxD) | 546x456x97 (4 from the wall) | x | 546x456x97 (4 from the wall) | 546x456x110 (12 from the wall) | 546x456x97 (4 from the wall) |
| Dimension 4 – 5 gases surface mounted (WxHxD) | 572x482x100 | x | 572x482x98 | 572x482x110 | 572x482x100 |
| Dimensions 6 gases surface mounted (WxHxD) | x | x | 572x662x100 | 572x662x110 | 572x662x100 |
| Dimensions 6 gases sunken mounted (WxHxD) | x | x | 572x662x97 (4 from the wall) | 572x662x110 (12 from the wall) | 572x662x97 (4 from the wall) |
| Standards and directives | EN ISO 7396-1, HTM 02-01 and MDD 93/42/EEC | | | | |

* optional equipment, • available option, x not applicable

13 Revision history

| DATE | VERSION | CHANGES |
|------------|---------|-----------------|
| 22.12.2021 | v2.0 | Initial release |



Medicop[®]
EQUIPMENT SPECIALIST

MEDICOP d.o.o.

Nemčavci 81

SI – 9000 Murska Sobota, Slovenia

T: +386 2 53 91 250 | F: +386 2 53 91 255

info@medicop.eu | www.medicop.eu