

Typical flow diagram of a Claus plant

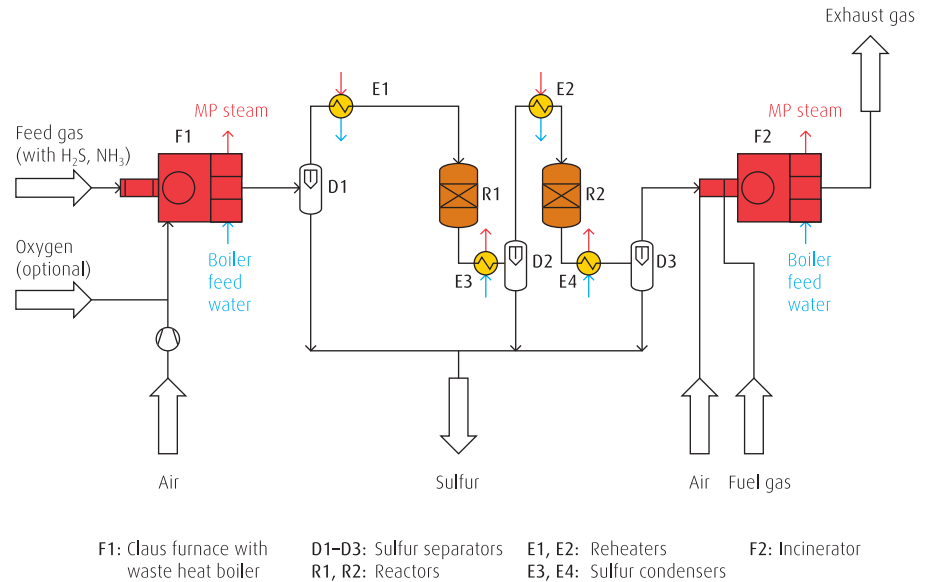

Intention

Claus plants serve the conversion of highly toxic hydrogen sulfide (H_2S) to harmless elemental sulfur. H_2S occurs in many chemical processes. Notably in refineries it results from desulfurization of crude oil by hydrogenation. When producing virtually sulfur-free fuels, additional H_2S is formed, requiring additional capacity in the Claus plant. Oxygen enrichment replaces some of the air for the Claus furnace by pure oxygen and thus generates additional capacity.

When hydrogenating crude oil, part of the organically bound nitrogen is converted to ammonia (NH_3). This, too, has to be treated in the Claus plant, requiring more capacity plus higher temperature for its decomposition. Oxygen enrichment can provide both – reliably, safely and at low operating costs.

In the Claus furnace (F1), one third of the H_2S is burned to SO_2 which then reacts further to elemental sulfur:

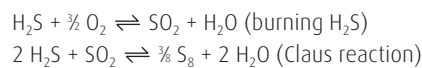

The process is continued in the catalytic reactors (R1/R2) to increase the yield. The generated sulfur is recovered in the sulfur condensers (E3/E4). Any residual sulfur in the process gas is burned in the incinerator (F2) prior to being released into the atmosphere.

Benefits

Oxygen enrichment results in a number of benefits. Most important are the capacity increase and the substantially improved ammonia destruction.

Capacity increase by oxygen enrichment

The increased capacity can, as shown in the diagram, be quite substantial. The capital and operating costs required are a lot lower than for an additional Claus plant.

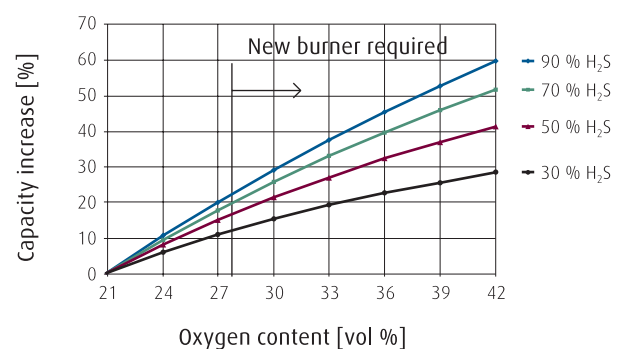

Efficiency of ammonia destruction

The destruction of ammonia ensures a reliable operation. Ammonia tends to form salts which deposit in the Claus plant and may cause plugging, corrosion and downtime. Oxygen enrichment increases ammonia destruction many times over (cf. the example shown in the diagram).

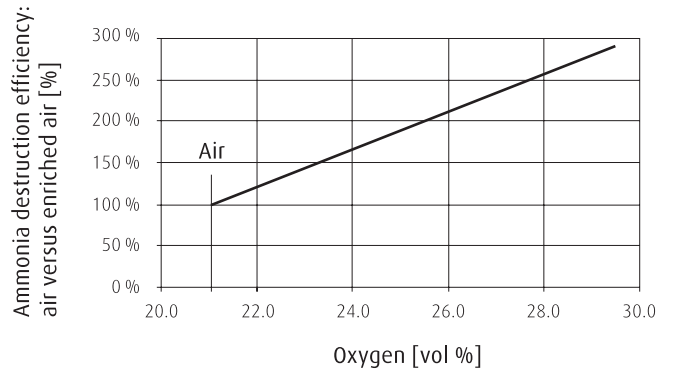

System

The complete system consists of an oxygen source, such as a liquid oxygen (=LOX) tank, or an air separation unit, an oxygen evaporator, a FLOWTRAIN™ device to meter the amount of oxygen, and an OXYMIX™ injector to ensure that the addition of oxygen into the air pipe is safe and according to the standards.

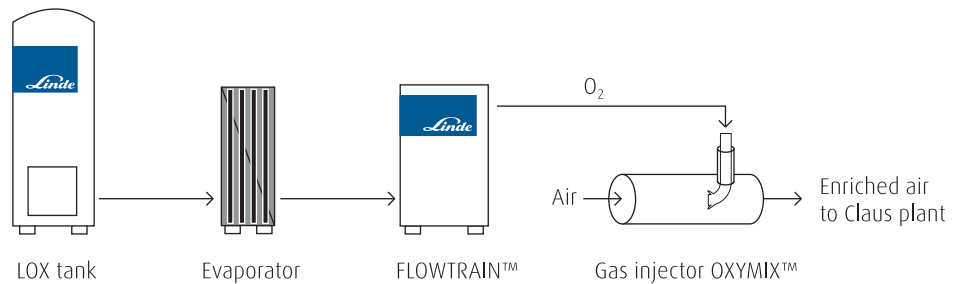

Process requirements

There are three stages of oxygen enrichment:

- Up to approx. 28 %, oxygen is just added to the air for the Claus furnace
- Between approx. 28 % and approx. 40 % oxygen, a new burner is required
- Beyond 40 % oxygen, a new burner, a new furnace and the recycling of product gas for temperature moderation are required

28 % oxygen enrichment allows approx. 25 % more capacity and a considerable increase in ammonia decomposition. This low enrichment level is inexpensive, already very efficient and therefore the most frequently used.

Services

- On-site demonstration of the technology and tests to prove the quantity of effects
- Simulation of oxygen enrichment in Claus plants using our proprietary software
- HAZOP and feasibility studies
- Delivery and installation of LOX tank, evaporator, FLOWTRAIN™ metering and safety system, OXYMIX™ injector for safe O₂ introduction according to standard regulations
- Reliable and flexible O₂ supply
- Ongoing technical support

Subject to change

43491189 1005 – 1.1 ku

FLOWTRAIN™ and OXYMIX™ are trademarks of the Linde Group.



Linde AG

Linde Gas Division, Seitnerstrasse 70, 82049 Höllriegelskreuth, Germany
Phone +49.89.74 46-0, Fax +49.89.74 46-12 30, www.linde-gas.com