



500SP 400SP TRANSMIG 320SP





Operation Manual

Version No:1 Issue Date: July 25, 2005

Manual No: 0-4773.001

Operating Features

 GMAW FCAW	 MMAW	 GTAW	 CAG	320 AMP	400 AMP	500 AMP	CC CV
DC		3 PHASE	415 V				



LEADER IN ARC WELDING TECHNOLOGY

We appreciate your business!

Congratulations on your new CIGWELD product. We are proud to have you as our customer and will strive to provide you with the best service and reliability in the industry. This product is backed by our extensive warranty and world-wide service network. To locate your nearest distributor or service agency call 1300-654-674, or visit us on the web at www.cigweld.com.au.

This Operating Manual has been designed to instruct you on the correct use and operation of your CIGWELD product. Your satisfaction with this product and its safe operation is our ultimate concern. Therefore please take the time to read the entire manual, especially the Safety Precautions. They will help you to avoid potential hazards that may exist when working with this product.

YOU ARE IN GOOD COMPANY

The Brand of Choice for Contractors and Fabricators. CIGWELD is the Market Leading Brand of Arc Welding Products for Thermadyne Industries Inc.

We are a mainline supplier to major welding industry sectors in the Asia Pacific and emerging global markets including; Manufacturing, Construction, Mining, Automotive, Engineering, Rural and DIY.

We distinguish ourselves from our competition through market leading dependable brands that have stood the test of time, technical innovation, competitive prices, excellent delivery, superior customer service and technical support, together with excellence in sales and marketing expertise.

We are committed to develop technologically advanced products to achieve a safer working environment for industry operators.



WARNING 1

Read and understand this entire Manual and your employer's safety practices before installing, operating, or servicing the equipment.

While the information contained in this Manual represents the Manufacturer's best judgement, the Manufacturer assumes no liability for its use.

Transmig Inverter Welding Power Supply
Instruction Manual Number 0-4773.001 for:

Transmig 500SP	Automation Power Supply with integrated cooler	Spec Number	W1000600
Transmig 400SP	Automation Power Supply with integrated cooler	Spec Number	W1000400
Transmig 500SP	Power Supply with integrated cooler	Spec Number	W1000500
Transmig 400SP	Power Supply with integrated cooler	Spec Number	W1000200
Transmig 400SP	Power Supply	Spec Number	W1000300
Transmig 320SP	Power Supply	Spec Number	W1000100

Published by:
CIGWELD Pty Ltd
71 Gower Street
Preston, Victoria, Australia, 3072

www.cigweld.com.au

Copyright 2001 by
CIGWELD

All rights reserved.

A reproduction of this work, in whole or in part, without written permission of the publisher is prohibited.

The publisher does not assume and hereby disclaims any liability to any party for any loss or damage caused by any error or omission in this Manual, whether such error results from negligence, accident, or any other cause.

Publication Date: **July 25, 2005**

Record the following information for Warranty purposes:

Where Purchased: _____

Purchase Date: _____

Equipment Serial #: _____

TABLE OF CONTENTS

SECTION 1:	Arc Welding Safety Instructions and Warnings	5
1.01	DECLARATION OF CONFORMITY	8
1.02	Limited Warranty	8
SECTION 2:	Introduction	10
2.01	How to Use This Manual.....	10
2.02	Equipment Identification.....	10
2.03	Receipt of Equipment	10
2.04	Machine components	10
SECTION 3:	Specification	11
SECTION 4:	Getting Started.....	12
4.01	Synergic Welding.....	12
4.02	Conventional Manual MIG Welding	13
4.03	GTAW Welding	13
4.04	Recommended Setup for MIG.....	13
SECTION 5:	Control Panels	15
SECTION 6:	Menu Structure	17
6.01	Secondary Parameters (Menu Main Level).....	19
SECTION 7:	Basic MIG Welding.....	22
7.01	Types of Weld Transfer Modes.....	22
7.02	Holding and Manipulating the Torch	22
SECTION 8:	Basics of Pulsed Arc Welding	23
SECTION 9:	Care and Maintenance.....	24
9.01	Troubleshooting Guide	25
9.02	Options	26

SECTION 1: Arc Welding Safety Instructions and Warnings



WARNING 2

ARC WELDING can be hazardous.

Protect yourself and others from possible serious injury or death. Keep children away. Pace maker wearers keep away until consulting your doctor. Do not lose these instructions. Read operating / instruction manual before installing, operating or servicing this equipment.

Welding products and welding processes can cause serious injury or death, or damage to other equipment or property, if the operator does not strictly observe all safety rules and take precautionary actions.

Safe practices have developed from past experience in the use of welding and cutting. These practices must be learned through study and training before using this equipment. Anyone not having extensive training in welding and cutting practices should not attempt to weld. Certain practices apply to equipment connected to power lines; other practices apply to engine driven equipment.

Safe practices are out lined in the American National Standard Z49.1 entitled: SAFETY IN WELDING AND CUTTING. This publication and other guides to what you should learn before operating this equipment are listed at the end of these safety precautions.

HAVE ALL INSTALLATION, OPERATION, MAINTENANCE, AND REPAIR WORK PERFORMED ONLY BY QUALIFIED PEOPLE.



ELECTRIC SHOCK can kill.

Touching live electrical parts can cause fatal shocks or severe burns. The electrode and work circuit is electrically live whenever the output is on. The input power circuit and machine terminal circuits are also live when power is on. In semiautomatic or automatic wire welding, the wire, wire reel, drive roll housing, and all metal parts touching the welding wire are electrically live. Incorrectly installed or improperly grounded equipment is a hazard.

1. Do not touch live electrical parts.
2. Wear dry, hole-free insulating gloves and body protection.
3. Insulate yourself from work and ground using dry insulating mats or covers.
4. Disconnect input power or stop engine before installing or servicing this equipment. Lock input power disconnect switch open, or remove line fuses so power cannot be turned on accidentally.
5. Properly install and ground this equipment according to its Owner's Manual and national, state, and 10 cal codes.

6. Turn off all equipment when not in use. Disconnect power to equipment if it will be left unattended or out of service.
7. Use fully insulated electrode holders. Never dip holder in water to cool it or lay it down on the ground or the work surface. Do not touch holders connected to two welding machines at the same time or touch other people with the holder or electrode.
8. Do not use worn, damaged, under sized or poorly spliced cables.
9. Do not wrap cables around your body.
10. Ground the workpiece to a good electrical (earth) ground.
11. Do not touch electrode while in contact with the work (ground) circuit.
12. Use only well-maintained equipment. Repair or replace damaged parts at once.
13. In confined spaces or damp locations, do not use a welder with AC output unless it is equipped with a voltage reducer. Use equipment with DC output.
14. Wear a safety harness to prevent falling if working above floor level.
15. Keep all panels and covers securely in place.
 1. Wear a welding helmet fitted with a proper shade of filter (see ANSI 249.1 listed in Safety Standards) to protect your face and eyes when welding or watching.
 2. Wear approved safety glasses. Side shields recommended.
 3. Use protective screens or barriers to protect others from flash and glare; warn others not to watch the arc.
 4. Wear protective clothing made from durable, flame-resistant material (wool and leather) and foot protection.
 5. Use approved earplugs or earmuffs if noise level is high.



**ARC RAYS can burn eyes and skin;
NOISE can damage hearing.**

Arc rays from the welding process produce intense heat and strong ultraviolet rays that can burn eyes and skin. Noise from some processes can damage hearing.

Eye protection filter shade selector for welding or cutting (goggles or helmet), from AWS A 8.2-73					
Welding or Cutting operation	Electrode size Metal Thickness or Welding Current	Filter shade no.	Welding or Cutting operation	Electrode size Metal Thickness or Welding Current	Filter shade no.
Torch soldering	All	2	Gas metal arc welding		
Torch brazing	All	2 or 3	Non Ferrous base metal	All	11
Oxygen cutting			Ferrous base metal	All	12
Light	Under 1 in., 25 mm	3 or 4	Gas tungsten arc welding (TIG)	All	12
Medium	1 – 6 in., 25 – 150 mm	4 or 5	Atomic Hydrogen welding	All	12
Heavy	Over 6 in., 150 mm	5 or 6	Carbon Arc welding	All	12
Gas welding			Plasma arc Welding	All	12
Light	Under 1/8 in., 3 mm	4 or 5	Carbon Arc Gouging		
Medium	1/8 – 1/2 in., 3 – 12 mm	5 or 6	Light		12
Heavy	Over 1/2 in., 12 mm	6 or 8	Heavy		14
Shielded metal-arc welding (stick) electrodes			Plasma arc cutting		
	Under 5/32 in., 4 mm	10	Light	Under 300 Amp	9
	Under 5/32 to 1/4 in., 4 to 6.4mm	12	Medium	300 to 400 Amp	12
	Over 1/4 in., 6.4 mm	14	Heavy	Over 400 Amp	14



FUMES AND GASES can be hazardous to your health.

Welding produces fumes and gases. Breathing these fumes and gases can be hazardous to your health.

1. Keep your head out of the fumes. Do not breathe the fumes.
2. If inside, ventilate the area and/or use exhaust at the arc to remove welding fumes and gases.
3. If ventilation is poor, use an approved air-supplied respirator.
4. Read the Material Safety Data Sheets (MSDS) and the manufacturer's instruction for metals, consumables, coatings, and cleaners.



WELDING can cause fire or explosion.

Sparks and spatter fly off from the welding arc. The flying sparks and hot metal, weld spatter, hot work piece, and hot equipment can cause fires and burns. Accidental contact of electrode or welding wire to metal objects can cause sparks, over

heating, or fire.

1. Protect yourself and others from flying sparks and hot metal.
2. Do not weld where flying sparks can strike flammable material. Remove all flammables within 35ft (10.7 m) of the welding arc. If this is not possible, tightly cover them with approved covers.



Flying sparks and hot metal can cause Injury

Chipping and grinding cause flying metal. As welds cool, they can throw off slag.

5. Work in a confined space only if it is well ventilated, or while wearing an air-supplied respirator. Shielding gases used for welding can displace air causing injury or death. Be sure the breathing air is safe.
6. Do not weld in locations near degreasing, cleaning, or spraying operations. The heat and rays of the arc can react with vapours to form highly toxic and irritating gases.
7. Do not weld on coated metals, such as galvanized lead, or cadmium plated steel, unless the coating is removed from the weld area, the area is well ventilated, and if necessary, while wearing an air supplied respirator. The coatings and any metals containing these elements can give off toxic fumes if welded.
3. Be alert that welding sparks and hot materials from welding can easily go through small cracks and openings to adjacent areas.
4. Watch for fire, and keep a fire extinguisher nearby.
5. Be aware that welding on a ceiling, floor, bulkhead, or partition can cause fire on the hidden side.
6. Do not weld on closed containers such as tanks or drums.
7. Connect work cable to the work as close to the welding area as practical to prevent welding current from travelling long, possibly unknown paths and causing electric shock and fire hazards.
8. Do not use welder to thaw frozen pipes.
9. Remove stick electrode from holder or cut off welding wire at contact tip when not in use.



CYLINDERS can explode if damaged.

Shielding gas cylinders contain gas under high pressure. If damaged, a cylinder can explode. Since gas cylinders are normally part of the welding process, be sure to treat them carefully.

1. Protect compressed gas cylinders from excessive heat, mechanical shocks, and arcs.
2. Install and secure cylinders in an upright position by chaining them to a stationary support or equipment cylinder rack to prevent falling or tipping.
3. Keep cylinders away from any welding or other electrical circuits.

1. Wear approved face shield or safety goggles. Side shields recommended.
2. Wear proper body protection to protect skin.

4. Never allow a welding electrode to touch any cylinder.
5. Use only correct shielding gas cylinders, regulators, hoses and fittings designed for the specific application; maintain them and associated parts in good condition.
6. Turn face away from valve outlet when opening cylinder valve.
7. Keep protective cap in place over valve except when cylinder is in use or connected for use.
8. Read and follow instructions on compressed gas cylinders, associated equipment, and CGA publication P-1 listed in Safety Standards.



WARNING 3

ENGINES can be dangerous.



ENGINE EXHAUST GASES can kill.

Engines produce harmful exhaust gases

1. Use equipment outside in open, well-ventilated areas.
2. If used in a closed area, vent engine exhaust outside and away from any building air intakes.



ENGINE FUEL can cause fire or explosion.

Engine fuel is highly flammable

1. Stop engine before checking or adding fuel.
2. Do not add fuel while smoking or if unit is near any sparks or open flames.

3. Allow engine to cool before fuelling. If possible, check and add fuel to cold engine before beginning job.
4. Do not overfill tank - allow room for fuel to expand away from any building air intakes.



MOVING PARTS can cause injury.

Moving parts, such as fans, rotors, and belts can cut fingers and hands and catch loose clothing.

1. Keep all doors, panels, covers, and guards closed and securely in place.
2. Stop engine before installing or connecting unit.

3. Have only qualified people remove guards or covers for maintenance and troubleshooting as necessary.
4. To prevent accidental starting during servicing, disconnect negative (-) battery cable from battery.
5. Keep hands, hair, loose clothing, and tools away from moving parts.
6. Re-install panels or guards and close doors when servicing is finished and before starting engine.



SPARKS can cause BATTERY GASES TO EXPLODE; BATTERY ACID can burn eyes and skin.

Batteries contain acid and generate explosive gases

1. Always wear a face shield when working on a battery.
2. Stop engine before disconnecting or connecting battery cables.
3. Do not allow tools to cause sparks when working on a battery.
4. Do not use welder to charge batteries or jump start vehicles.



STEAM AND PRESSURIZED HOT COOLANT can burn face, eyes, and skin.

The coolant in the radiator can be very hot and under pressure

1. Do not remove radiator cap when engine is hot. Allow engine to cool.
2. Wear gloves and put a rag over cap area when removing cap.
3. Allow pressure to escape before completely removing cap.

WARNING: This product, when used for welding or cutting, produces fumes or gases which contain chemicals known to the State of California to cause birth defects and, in some cases, cancer. (California Health & Safety Code Sec. 25249.5 et seq.)

NOTE: Considerations About Welding And The Effects Of Low Frequency Electric And Magnetic Fields

The following is a quotation from the General Conclusions Section of the U.S. Congress, Office of Technology Assessment, Biological Effects of Power Frequency Electric & Magnetic Fields Background Paper OTA-BP-E-63 (Washington, DC: U.S. Government Printing Office, May 1989): "...there is now a very large volume of scientific findings based on experiments at the cellular level and from studies with animals and people which clearly establish that low frequency magnetic fields can interact with, and produce changes in, biological systems. While most of this work is of very high quality, the results are complex. Current scientific understanding does not yet allow us to interpret the evidence in a single coherent framework. Even more frustrating, it does not yet allow us to draw definite conclusions about questions of possible risk or to offer clear science based advice on strategies to minimize or avoid potential risks."

To reduce magnetic fields in the work place, use the following procedures:

1. Keep cables close together by twisting or taping them.
2. Do not coil or drape cables around the body.
3. Arrange cables to one side and away from the operator.
4. Keep welding power source and cables as far away from body as practical.

About Pacemakers: The above procedures are among those also normally recommended for pacemaker wearers. Consult your doctor for complete information.

1.01 DECLARATION OF CONFORMITY

Manufacturer and Merchandiser of Quality Consumables and Equipment: CIGWELD
Address: 71 Gower St, Preston
Victoria 3072
Australia



Description of equipment: Welding Equipment (GMAW, MMAW, GTAW, and CAG). CIGWELD TRANSMIG 500SP, 400SP, 320SP and associated accessories.

- * Serial numbers are unique with each individual piece of equipment and details description, parts used to manufacture a unit and date of manufacture.
- * The equipment conforms to all applicable aspects and regulations of the 'Low Voltage Directive' (Directive 73/23/EU, as recently changed in Directive 93/68/EU and to the National legislation for the enforcement of the Directive.

National Standard and Technical Specifications

The product is designed and manufactured to a number of standards and technical requirements among them are:

- * AS1966-1 applicable to welding equipment and associated accessories.
- * AS/NZS 3652-(EMC Directive EN50199) applicable to arc welding equipment - generic emissions and regulations.
- * EN60974-1 applicable to welding equipment and associated accessories.

- * Extensive product design verification is conducted at the manufacturing facility as part of the routine design and manufacturing process, to ensure the product is safe and performs as specified. Rigorous testing is incorporated into the manufacturing process to ensure the manufactured product meets or exceeds all design specifications.

CIGWELD has been manufacturing and merchandising an extensive equipment range with superior performance, ultra safe operation and world class quality for more than 30 years and will continue to achieve excellence.

1.02 Limited Warranty

LIMITED WARRANTY: CIGWELD, A Thermadyne Company, hereafter, "CIGWELD" warrants to customers of its authorized distributors hereafter "Purchaser" that its products will be free of defects in workmanship or material. Should any failure to conform to this warranty appear within the time period applicable to the CIGWELD products as stated below, CIGWELD shall, upon notification thereof and substantiation that the product has been stored, installed, operated, and maintained in accordance with CIGWELD's specifications, instructions, recommendations and recognized standard industry practice, and not subject to misuse, repair, neglect, alteration, or accident, correct such defects by suitable repair or replacement, at CIGWELD's sole option, of any components or parts of the product determined by CIGWELD to be defective.

CIGWELD MAKES NO OTHER WARRANTY, EXPRESS OR IMPLIED. THIS WARRANTY IS EXCLUSIVE AND IN LIEU OF ALL OTHERS, INCLUDING, BUT NOT LIMITED TO ANY WARRANTY OF MERCHANTABILITY OR FITNESS FOR ANY PARTICULAR PURPOSE.

LIMITATION OF LIABILITY: CIGWELD SHALL NOT UNDER ANY CIRCUMSTANCES BE LIABLE FOR SPECIAL, INDIRECT OR CONSEQUENTIAL DAMAGES, SUCH AS, BUT NOT LIMITED TO, LOST PROFITS AND BUSINESS INTERRUPTION. The remedies of the Purchaser set forth herein are exclusive and the liability of CIGWELD with respect to any contract, or anything done in connection therewith such as the performance or breach thereof, or from the manufacture, sale, delivery, resale, or use of any goods covered by or furnished by CIGWELD whether arising out of contract, negligence, strict tort, or under any warranty, or otherwise, shall not, except as expressly provided herein, exceed the price of the goods upon which such liability is based. No employee, agent, or representative of CIGWELD is authorized to change this warranty in any way or grant any other warranty.

PURCHASER'S RIGHTS UNDER THIS WARRANTY ARE VOID IF REPLACEMENT PARTS OR ACCESSORIES ARE USED WHICH IN CIGWELD'S SOLE JUDGEMENT MAY IMPAIR THE SAFETY OR PERFORMANCE OF ANY CIGWELD PRODUCT. PURCHASER'S RIGHTS UNDER THIS WARRANTY ARE VOID IF THE PRODUCT IS SOLD TO PURCHASER BY NON-AUTHORIZED PERSONS.

The warranty is effective for the time stated below beginning on the date that the authorized distributor delivers the products to the Purchaser. Notwithstanding the foregoing, in no event shall the warranty period extend more than the time stated plus one year from the date CIGWELD delivered the product to the authorized distributor.

Terms of Warranty – July 2005

1. The Trade Practices Act 1974 (Commonwealth) and similar State Territory legislation relating to the supply of goods and services, protects consumers' interests by ensuring that consumers are entitled in certain situations to the benefit of various conditions, warranties, guarantees, rights and remedies (including warranties as to merchantability and fitness for purpose) associated with the supply of goods and services. A consumer should seek legal advice as to the nature and extent of these protected interests. In some circumstances, the supplier of goods and services may legally stipulate that the said conditions, warranties, guarantees, rights and remedies are limited or entirely excluded. The warranties set out in Clause 2 shall be additional to any non-excludable warranties to which the Customer may be entitled pursuant to any statute.
2. Subject to Clause 3. CIGWELD gives the following warranties to the Customer:
 Insofar as they are manufactured or imported by CIGWELD, goods will upon delivery be of merchantable quality and reasonably fit for the purpose for which they are supplied by CIGWELD.

 CIGWELD will repair or, at its option, replace those of the goods which, upon examination, are found by CIGWELD to be defective in workmanship and/or materials.

 CIGWELD reserves the right to request documented evidence of date of purchase.
3. The Warranty in Clause 2;

 Is conditional upon:

 The Customer notifying CIGWELD or our Accredited Distributor in writing of its claim within seven (7) days of becoming aware of the basis thereof, and at its own expense returning the goods which are the subject of the claim to CIGWELD or nominated Accredited Distributor/Accredited Service Provider.

 The goods being used in accordance with the Manufacturer's Operating Manuals, and under competent supervision.

 Does not apply to:
 Obsolete goods sold at auction, second-hand goods and prototype goods.
 Breakdown or malfunction caused by accident, misuse or normal wear and tear.
 Repairs or replacement made other than by CIGWELD or Accredited Service Providers, unless by prior arrangement with CIGWELD.
 Replacement parts or accessories which may affect product safety or performance and which are not manufactured, distributed or approved by CIGWELD.
4. CIGWELD declares that, to the extent permitted by law, it hereby limits its liability in respect of the supply of goods which are not of a kind ordinarily acquired for personal, domestic or household use or consumption to any one or more of the following (the choice of which shall be at the option of CIGWELD).

 The replacement of the goods or the supply of equivalent goods.
 The repair of goods.
 The payment of cost of replacing the goods or acquiring equivalent goods.
 The payment of the cost of having goods repaired.
5. Except as provided in Clauses 2 to 4 above, to the extent permitted by statute, CIGWELD hereby excludes all liability for any loss, damage, death or injury of any kind whatsoever occasioned to the Customer in respect of the supply of goods including direct, indirect, consequential or incidental loss, damage or injury of any kind.

Warranty Schedule – July 2005

These warranty periods relate to the warranty conditions in clause 2. All warranty periods are from date of sale from the Accredited Distributor of the equipment. Notwithstanding the foregoing, in no event shall the warranty period extend more than the time stated plus one year from the date CIGWELD delivered the product to the Accredited Distributor. Unless otherwise stated the warranty period includes parts and labour.

CIGWELD reserves the right to request documented evidence of date of purchase.

MULTI PROCESS EQUIPMENT	WARRANTY PERIOD
Transmig 320SP; Transmig 400SP; Transmig 500SP	
Main Power Magnetics	3 years (Labour 1 year)
Original Main Power Rectifier, Control P.C. Boards.....	3 years (Labour 1 year)
All other circuits and components including, but not limited to, relays, switches, contactors, solenoids, fans, power switch semi-conductors.....	1 year
WIREFEEDER EQUIPMENT	
SP4000G; SP4000W; SP4000R	
Control P.C. Board	3 years (Labour 1 year)
All other circuits and components including, but not limited to, relays, switches, contactors, solenoids, fans, power switch semi-conductors.....	1 year
ACCESSORIES	
Control P.C. Board	3 years (Labour 1 year)
All other circuits and components including, but not limited to, relays, switches, contactors, solenoids, fans, motors, pumps, power switch semi-conductors	1 year
MIG Torch (where fitted).....	3 months
MIG Torch Consumable Items.....	Nil

Transmig 320SP, 400SP, 500SP

Please note that the information detailed in this statement supersedes any prior published data produced by CIGWELD.



WARNING 4

For the purpose of safety and performance and to protect your CIGWELD Equipment Warranty always use genuine CIGWELD replacement parts and accessories.

SECTION 2: Introduction

2.01 How to Use This Manual

This Owner's Manual usually applies to just the underlined specification or part numbers listed on the page 3. If none are underlined, they are all covered by this manual.

To ensure safe operation, read the entire manual, including the chapter on safety instructions and warnings. Throughout this manual, the word **WARNING**, **CAUTION** and **NOTE** may appear. Pay particular attention to the information provided under these headings. These special annotations are easily recognized as follows:



WARNING

Gives information regarding possible personal injury. Warnings will be enclosed in a box such as this.

CAUTION

Refers to possible equipment damage. Cautions will be shown in bold type.

NOTE

Offers helpful information concerning certain operating procedures. Notes will be shown in italics.

2.02 Equipment Identification

The unit's identification number (specification or part number), model, and serial number usually appear on a nameplate attached to the machine.

Equipment which does not have a nameplate attached to the machine is identified only by the specification or part number printed on the shipping container. Record these numbers for future reference.

2.03 Receipt of Equipment

When you receive the equipment, check it against the invoice to make sure it is complete and inspect the equipment for possible damage due to shipping. If there is any damage, notify the carrier immediately to file a claim. Furnish complete information concerning damage claims or shipping errors to:

CIGWELD, Customer Care Department, 71 Gower St, Preston, Victoria, Australia, 3072.

Include all equipment identification numbers as described above along with a full description of the parts in error.

Additional copies of this manual may be purchased by contacting CIGWELD, Customer Care Department, at the address given above. Include the Owner's Manual number and equipment identification numbers.

2.04 Machine components

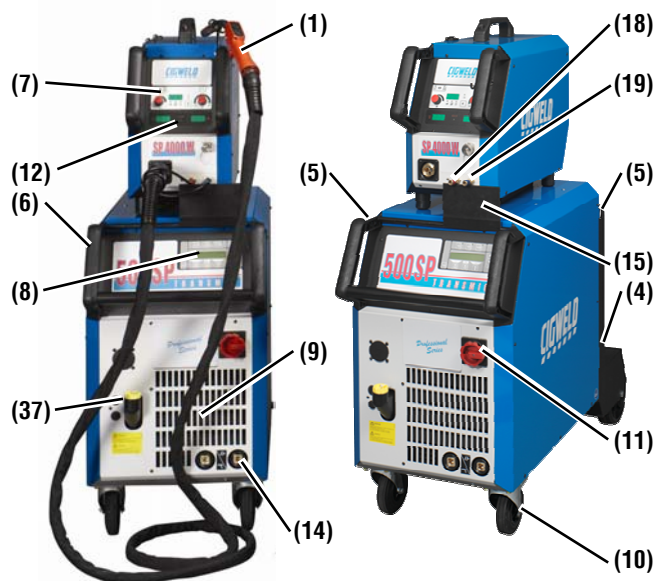

- (1) MIG Torch
- (2) Gas Regulator (not shown)
- (3) Gas Cylinder (not shown)
- (4) Gas Cylinder Tray
- (5) Lifting Points
- (6) Handle
- (7) Primary Control Operating Panel
- (8) Secondary Control Operating Panel
- (9) Air intake
- (10) Wheeling Gear
- (11) Mains On/Off Switch
- (12) Preview and actual welding current and voltage
- (13) Work Clamp (not shown)
- (14) Negative Connection Socket for Work Lead
- (15) Protective cover, operation panel
- (18) Red = Hot coolant return
- (19) Blue = Cool coolant to torch
- (37) Coolant tank cap

SECTION 3: Specification

Power Source Part Numbers		320SP	400SP	500SP
Compact with Integrated Wirefeeder		W1000100	–	–
Remote Power Source suits air cooled system		–	W1000300	–
Remote Power Source with Integrated Cooler		–	W1000200	W1000500
Remote Automation Power Source		–	W1000400	W1000600
Welding Output				
Welding Current Range (I_{2min} - I_{2max})	A	5 – 320	5 – 400	5 – 500
Welding MIG Voltage Range (U_{2min} - U_{2max})	V	15.2 – 30	15.2 – 34	15.2 – 39
Nominal DC Open Circuit Voltage (OCV)	V	81	81	81
Nominal DC OCV in MMA Mode (VRD ON)	V	26	26	26
Voltage/Current Adjustment Continuously Variable		Yes	Yes	Yes
Duty cycle 100% (At 40 °C)	A	250	320	400
Duty cycle 60% (At 40 °C)	A	270	350	500
Duty cycle at max. current (At 40 °C)		35%@320A	50%@400A	60%@500A
Weldable Wire Steel & Stainless Steel	Ø mm	0.6 – 1.2	0.6 – 1.2	0.6 – 1.6
Weldable Wire Aluminium	Ø mm	1.0 – 1.2	1.0 – 1.6	1.0 – 2.4
Welding Electrodes	Ø mm	2.0 – 6.0	2.0 – 8.0	2.0 – 8.0
Wirefeed Speed	m/min	0.1 – 25	n/a	n/a
Mains Power				
Mains voltage 3~ (50/60 Hz)	V	415	415	415
Mains voltage tolerance range	%	+/- 10	+/- 10	+/- 10
Input power S_1 (100% At 40 °C)	kVA	10.7	14.3	19
Input power S_1 (60% At 40 °C)	kVA	12.6	16.1	26.1
Input power S_1 (max. current)	kVA	15.1	19.4	26.1
♣ Generator Requirement	kVA			
Current input I_1 (100% At 40 °C)	A	14.9	20.0	26.5
Current input I_1 (60% At 40 °C)	A	17.5	22.5	36.3
Current input I_1 (maximum current)	A	21.0	27.1	36.3
Power factor (At I_{2max})	cos	0.99	0.99	0.99
✦ Mains fuse/circuit breaker	A	32	32	63
Classification				
Protection class (EN 60 529)		IP23	IP23	IP23
Insulation class		F	F	F
Cooling method		Fan Cooled	Fan Cooled	Fan Cooled
Noise emission	dB (A)	<70	<70	<70
Cooling system (Where Fitted)				
Standard cooling power (l/min)	kW	n/a	1.1	1.1
Maximum pressure	Pmax (bar)	n/a	3.5	3.5
Pump		n/a	Centrifugal pump	Centrifugal pump
Dimensions and weights				
Dimension power source (DxWxH)	mm	745x340x498	1116x445x855	1116x445x855
Weight of power source	kg	35	91.3	100.8
Standard equipment				
Wire feed unit	Rollers	4	n/a	n/a
Wire diameter	mm	0.9/1.2	n/a	n/a

♣ Minimum Generator Requirements at the Maximum Output Duty Cycle.

✦ Motor start fuses or thermal circuit breakers are recommended for this application. Check local requirements for your situation in this regard.

Transmig 320SP, 400SP, 500SP

Wirefeeder Part Numbers		SP4000G	SP4000W	SP4000R
Wirefeeder suits air cooled torch		–	W3000100	–
Wirefeeder suits coolant cooled torch		W3000200	–	–
Wirefeeder suits Automation Power Source		–	–	W3000300
Welding Output				
Weldable Wire Steel & Stainless Steel	Ø mm	0.6 – 1.2	0.6 – 1.2	0.6 – 1.6
Weldable Wire Aluminium	Ø mm	1.0 – 1.2	1.0 – 1.6	1.0 – 2.4
Wirefeed Speed	m/min	0.1 – 25	0.1 – 25	0.1 – 25
Wire feed unit	Rollers	4	4	4
Wire diameter	mm	0.9/1.2	0.9/1.2	0.9/1.2
Dimensions and weights				
Size of wire feed case (DxWxH)	mm	639x281x498	639x281x498	540x207x178
Weight of wire feed case	kg	20.2	20.2	8.5

NOTE 1

Due to variations that can occur in manufactured products, claimed performance, voltages, ratings, all capacities, measurements, dimensions and weights quoted are approximate only. Achievable capacities and ratings in use and operation will depend upon correct installation, use, applications, maintenance and service.

SECTION 4: Getting Started

NOTE 2

Please refer to Sections 4.04 Recommended Setup and SECTION 5: Control Panel for explanations of the controls.



WARNING 5

CIGWELD advises that a suitable Mains Plug be fitted to this equipment by a qualified electrical trades-person.





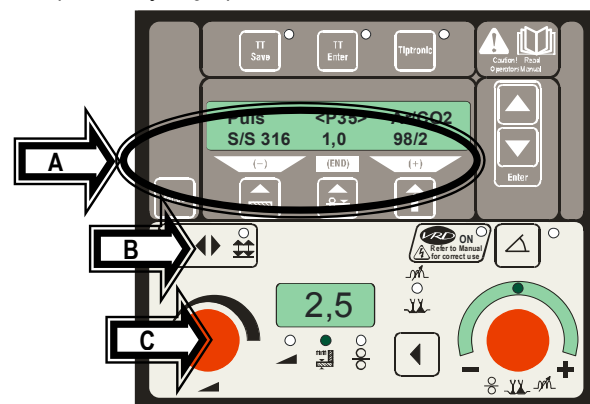

- Where fitted, place the gas cylinder on machines cylinder tray (4) and secure with the two safety chains (35). If this arrangement is not used then ensure that the gas cylinder is secured to a building pillar, wall bracket or otherwise securely fixed in an upright position.
- Remove screw cap from gas cylinder, if fitted, and open gas cylinder valve (34) briefly to remove contaminants.
- Connect gas regulator to gas cylinder.
- Connect gas hose (31) from machine to gas regulator and open gas cylinder valve.
- Plug Mains Plug in a suitable socket, refer to WARNING 5.
- Connect work lead (22) to Negative connection (14) (–) and attach Work clamp (13) to workpiece.
- Fit the correct size feed rollers (29) to wire feeder then fit the selected welding wire and set the pressure levers (27) to position 2.
- Connect torch (1) (central socket (16), coolant connections (20) red-blue) and mount contact tip to fit welding wire selected.
- Insert welding wire.
- Turn on main switch (11).
- Press push-button (51) ▲ and push-button (48) (gas type) (solenoid valve is activated) and adjust gas amount on the gas regulator (rule of thumb: wire diameter x 10 = gas flow).

- Keep the wire inch switch  pressed until the welding wire protrudes approximately 10 mm out of the MIG torch nozzle.

4.01 Synergic Welding

The following instructions explain how to set up for synergic non-pulse or synergic pulse or Twin Pulse.



- A Set Mode**
 - Mode:  Normal = Synergic non-pulse, Pulse = Synergic pulse, TwinPulse = Synergic TwinPulse
 - Wire Type: 
 - Wire size: 
 - Shielding Gas: 
 - Set LED to: 
- B Set Torch trigger operation**
 -  ↑ = 2T Normal Operation, ↓ = 4T Trigger Latch
- C Set Material Thickness**
 -  2,5

4.02 Conventional Manual MIG Welding

The following instructions explain how to set up for conventional manual MIG welding.

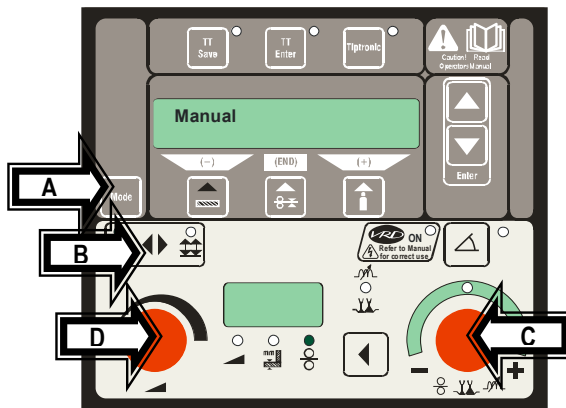

- A Set *Mode to Manual*
- B Set *Torch trigger operation*
 ↑ = 2T Normal Operation
 ↓ = 4T Trigger Latch
- C Set *Wirefeed speed knob*
- D Set *Arc Voltage knob*

4.03 GTAW Welding

The following instructions explain how to set up for GTAW (TIG) welding with VRD on.

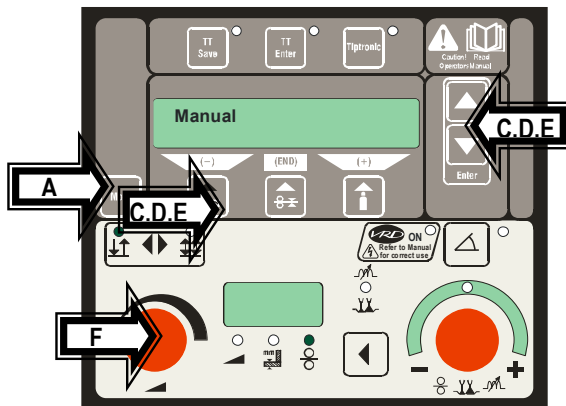

- A Set *Mode to MMA*
- B Press *Press the up button* To confirm MMA mode is required
- C Press *To display Arc dynamic*
 Then Press (-) to reduce value to 0% for GTAW
- D Press *To display Start Current*
 Then Press (-) to reduce value to 20% for GTAW

E Press *To display Start Time*

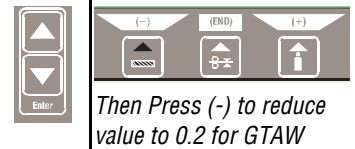

F Set *Weld Current knob*



4.04 Recommended Setup for MIG

Torch connection

Fit the MIG Torch (17) to the Euro adaptor (16) by pushing the torch connector into the brass torch adaptor and screwing the plastic torch nut clockwise to secure the torch to the torch adaptor. Remove the contact tip from the torch handset. If a coolant-cooling system is fitted then connect the coolant connections (20) of the torch with the sockets (18) and (19). Connect the red fitting together and the blue fittings together.

Red = Hot coolant return (18)
Blue = Cool coolant to torch (19)

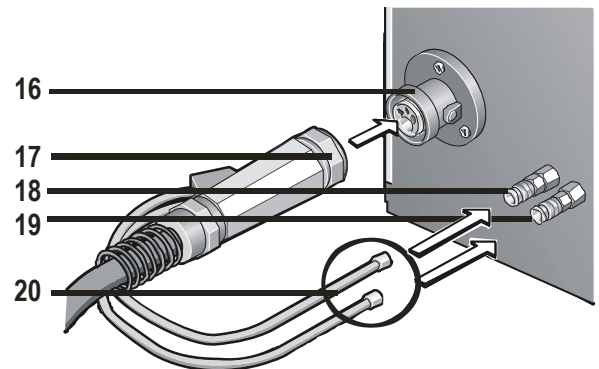

How to connect the work lead

Connect the work lead (22) to the Negative connection (14) and fasten it by turning the connector to the right. Connect the Work clamp (13) to the workpiece or at the welding table.

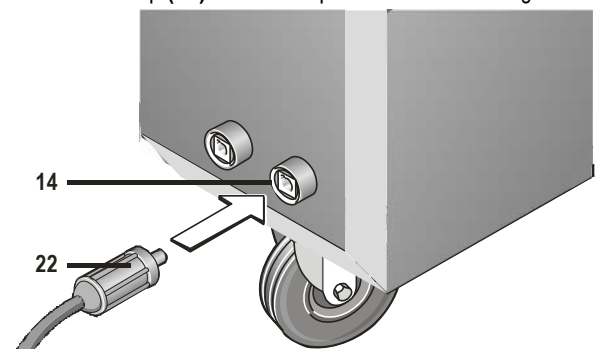

Where to connect the Work Clamp

Fasten the Work clamp (13) near the welding location; this avoids stray current flow through mains earthing system.

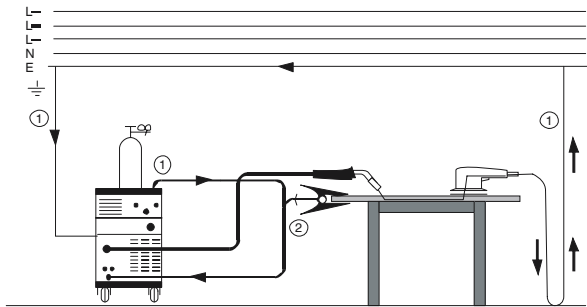

WARNING 6

Do not place the Work clamp on the welding machine or gas cylinder as welding current may conducted via the mains earth and will burn it out.

Connect the Work clamp tightly to the welding bench or to the workpiece.

How to connect at the mains

Plug in the plug into a suitable mains socket. The fuses or circuit breaker should correspond to the specification data.

How to fit the wire spool

Open the wire feed compartment lid on the machine or wire-feed case and un-screw the nut (26) from the wire support coil hub (24).

Place wire spool on the hub (24) and ensure that the drive dog-pin (23) engages the mating hole in the wire spool.

Press then release the inch switch  to adjust the brake (25), the wire spool should not continue to run on.

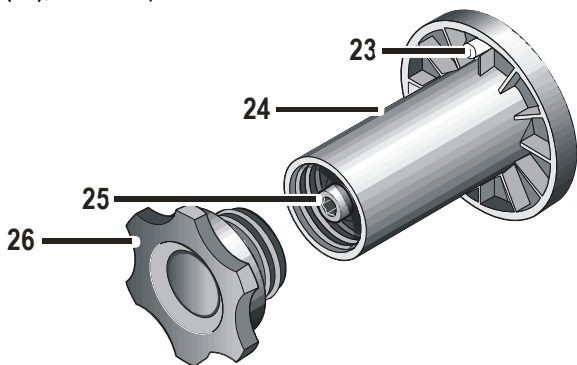

Insert of the wire electrode

Un-screw the contact tip in the MIG torch handset.

Open the wire feed compartment lid on the machine or wire-feed case.

The diameter of the wire should correspond to the diameter of the feedrolls. The wire size is on the face of the feedrolls.

Open the pressure lever (27) and thread the wire through the inlet guide (28) and the outlet guide (16).

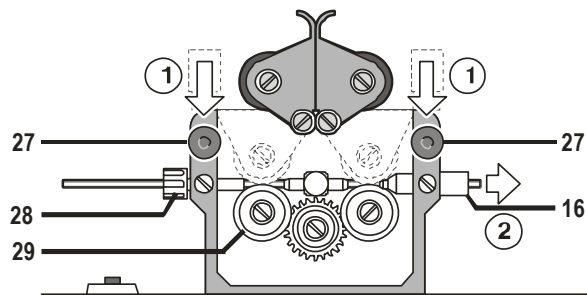

Close the lever (30) and fasten the pressure rollers (27).

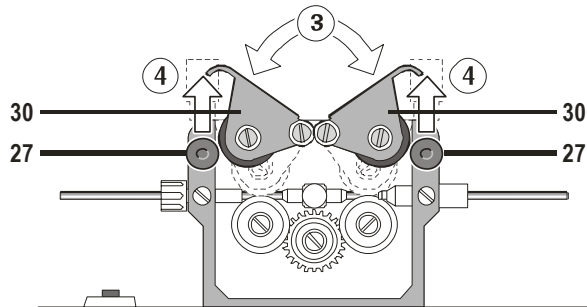

Switch on machine at main switch (11), stretch torch cable out straight and press the inch button switch  in the wire feed compartment. Adjust the pressure at the pressure adjustment screws (27) so the wire-feed rolls drive the wire consistently without slipping. The wire should not be deformed.

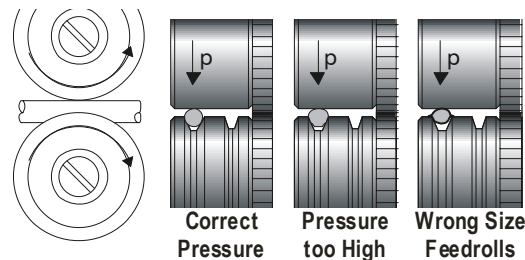

Adjust the pressure adjustment (27) next to the inlet guide (28) to a lower pressure less then the pressure adjustment (27) next to the outlet guide (16), this will ensure that the wire will be locate correctly in the wire-feed unit.

Press the inch switch  till the wire appears approximately 20 mm out of the torch neck.

Screw in the contact tip corresponding to the wire diameter and cut off the wire stick out.

How to connect the gas cylinder

If the Wheeling Kit is fitted, position a gas cylinder on the rear tray and lock securely to the Power Source cylinder bracket with the chains provided. If this arrangement is not used then ensure that the gas cylinder is secured to a building pillar, wall bracket or otherwise securely fixed in an upright position.

Open the gas valve once to blow out possible dirt particles.

Connect the gas regulator to the gas cylinder valve.

Connect the gas hose to the gas regulator.

Open the gas cylinder valve and adjust the gas flow on the gas regulator while pressing the torch trigger switch.

The quantity will be shown at the flowmeter.

This should be approximately wire diameter x 10 l/min.

How to refill the cooling fluid

Only use original MIG/TIG coolant for refill. It provides protection against frost down to -20°C. If using other coolants, the coolant pump could be damaged.

Coolant circulation has to be checked at regular intervals. Reliable coolant return flow is essential to ensure the coolant is not lost and the coolant cooled MIG torch is not damaged.

Check the level of the coolant every day before operating. The coolant must be visible when the tank cap (37) is removed.

CAUTION 1

Remove the pin from the breather hole in the cap of the coolant tank as leaving the pin in the cap may cause a coolant flow error.

MIG/TIG Coolant 5 Litre:

Part No. W4001400

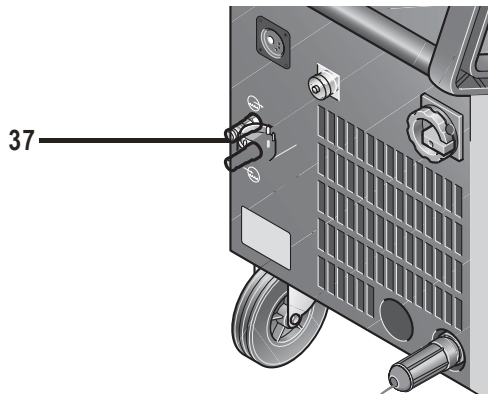

How to configure the machine for aluminium welding

Change the feedrolls to U groove for aluminium wire.

Change the torch liner to a nylon or teflon liner.

Remove the capillary tube (42) at the central connection.

Cut the teflon liner close to the end of the feedroll and pull the brass tube over the teflon liner with the corresponding length to stabilise it.

Fasten the torch and thread in the wire electrode.

NOTE 3

The parts required for the torch depends on the type torch and wire diameter. Please refer to the torch spare list.

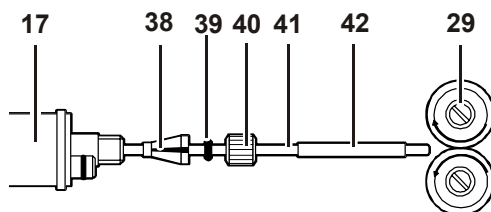

- (17) Central connection
- (38) Nipple for 4.0 mm and 4.7 external diameter
- (39) O-ring 3,5 x 1.5 mm to prevent gas outlet
- (40) Nut
- (41) Nylon or Teflon liner
- (42) Support tube for nylon or teflon liner with 4 mm OD, it substitute the outlet guide in the central connection

(16). A 4.7 mm diameter liner does not require the support tube is required.

(29) Feedroll

SECTION 5: Control Panels

This section explains the Secondary Control Panel (8) and Primary Control Panel (7) displays and buttons.

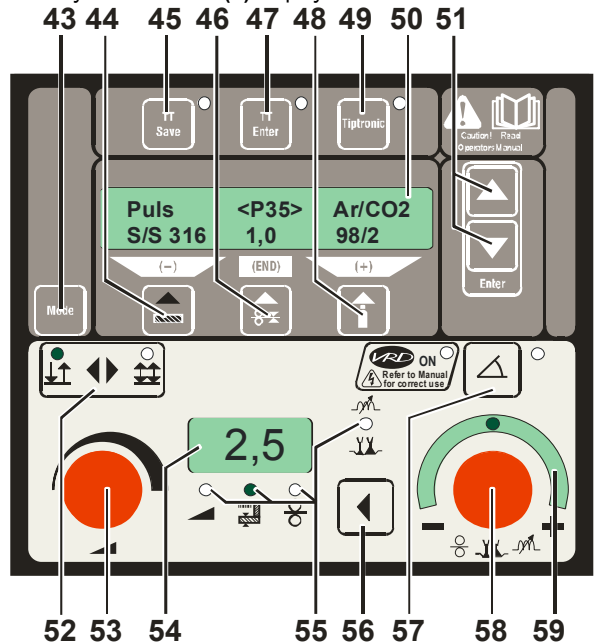

- (43) "Mode" push-button
For switching between the operation modes
Normal = Synergic non-pulse MIG;
Pulse = Synergic pulse MIG;
TwinPulse = Synergic TwinPulse pulse MIG;
MMA = Programmable scratch start TIG OR Stick welding with VRD;
- (44) "Material" push-button
For selection of the wire material to be welded. The push-button is also used for the "Decrement" (-) function, e. g., to reduce the value of a secondary parameter.
- (45) "TT Save" push-button (Tiptronic)
For saving user-defined, frequently used welding jobs.
- (46) "Welding wire diameter" push-button
For diameter selection of the wire to be welded. The push-button is also used for the "End" function, which you can move back up to the previous menu level.
- (47) "TT Enter" push-button (Tiptronic)
For acknowledgement when saving a welding job.
- (48) "Gas type" push-button
For selection of the gas to be used. The push-button is also used for the "increment" (+) function, e. g., to increase the value of a secondary parameter.
- (49) "Tiptronic" push-button
For switching the Tiptronic mode on or off.
- (50) Multi-function display
For indication of all parameter values and messages.
- (51) ▼ and ▲ push-buttons (Enter)
For switching between the individual secondary parameters. Pressing both push-buttons at the same time is used for acknowledgement (Enter).

Transmig 320SP, 400SP, 500SP

- (52) “2 stroke (2T) / 4 stroke (4T)” push-button
For switching between 2T and 4T (Latch) operation mode. A lit LED indicates the currently selected operating mode.
- (53) “Synergic Power” control knob
Sets welding current or material thickness or wire speed in Normal, Pulse, TwinPulse mode.
OR
“Arc Voltage” control knob
Sets welding arc voltage in Manual mode.
- (54) “Digital multifunction” display
Displays the primary parameters such as welding current, material thickness (in mm), wire feed speed (in m/min) or arc length trim.
- (55) “Primary parameter” Indicator Lights
These lights show which primary parameter is currently displayed in the multifunction display (54).
- (56) “Primary parameter” push-button
For switching between welding current, material thickness, wire feed speed and arc length, as indicated in the digital multifunction display (54).
- (57) “Downslope” push-button
Switches the downslope function on or off. A lit LED next to the push-button indicates that the downslope is on.
- (58) “Arc length” control knob
To adjust the arc length in Normal, Pulse, TwinPulse mode.
OR
“Wire speed/Inductance” control knob
To adjust the wire speed or Inductance in Manual mode.
- (59) “Arc length” LED indication
Indicates the degree of the trim in Normal, Pulse, TwinPulse mode.
OR
“Wire speed” LED indication
Indicates the wire speed in Manual mode.

When the uppermost centre LED is lit, the programmed arc length/wire speed remains unchanged; “0” is indicated in the multifunction display (54). Turn the rotary control knob (58) left to shorten the arc length/wire speed; turn the rotary control knob (58) right to lengthen the arc length/wire speed



- (60) Smart Torch display
Indicates the welding current or arc length trim; material thickness or arc length trim; wire feed speed or arc length trim (Linked to the digital multifunction display (54)).
In Tiptronic mode, the current job set and the current job number are displayed.

- (61) Smart torch rocker
Changes the welding current, material thickness, arc length to the arc length (depending on which value is being displayed on the digital multifunction display (54)).
In Tiptronic mode, the rocker can be used to switch between the active jobs or job sets.
- (62) Smart torch push-button
Has the same function as the “Primary parameter” push-button (56) on the *Control Panel*.
In Tiptronic mode this push-button can be used to switch between job selection and job-set selection.

Current / voltage display

The actual welding voltage and welding current values are indicated during welding. After the welding procedure, the “Hold” LED illuminates and the last welding voltage and welding current values are indicated. When the operator changes certain welding adjustments (e.g. thickness, program, job), the “Hold” LED goes out and the preview values for current and voltage are displayed.



SECTION 6: Menu Structure

Menu structure

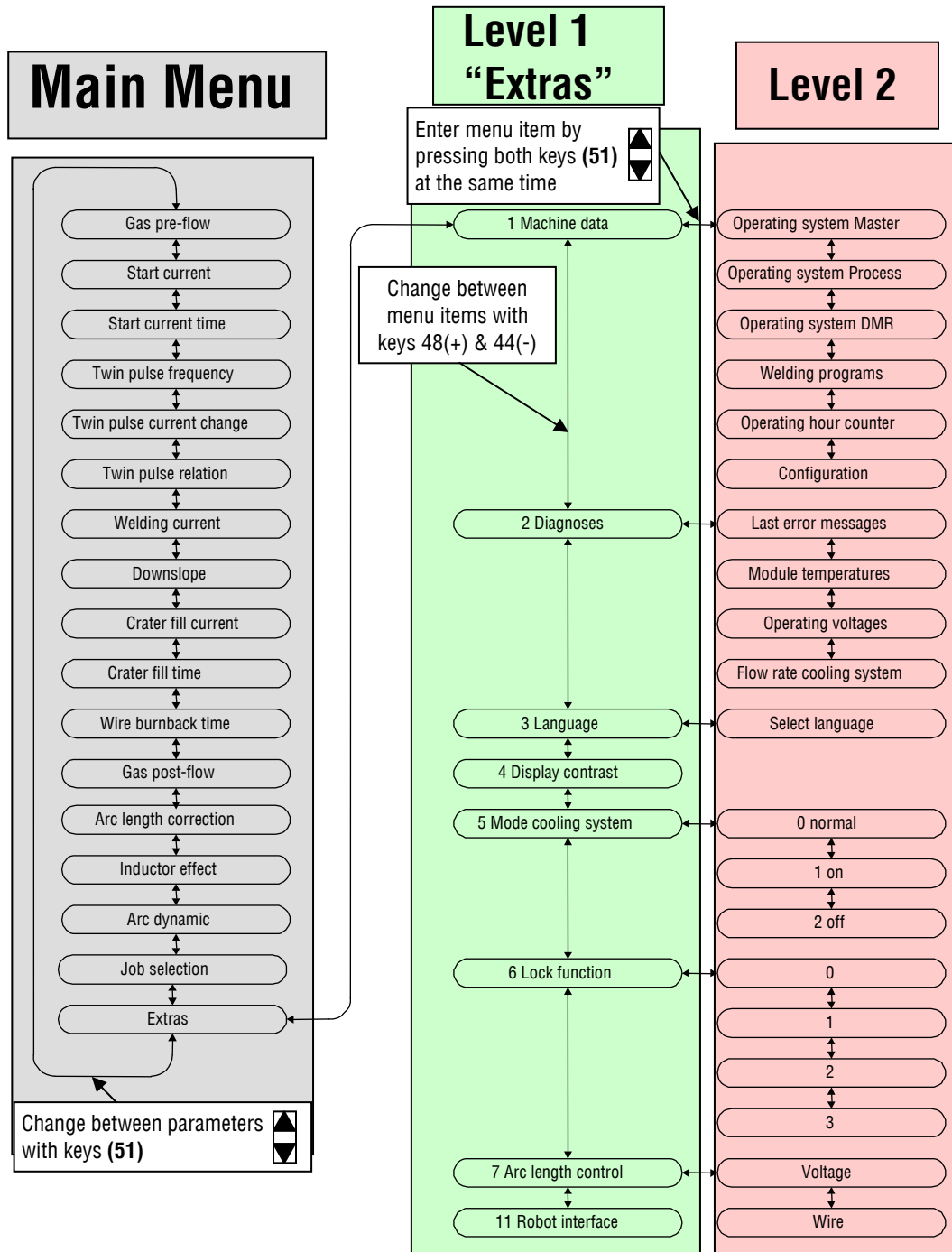

Main Level	Level 1	Level 2	Remark
Gas pre-flow			0 – 10 sec.; not in MMA electrode mode
Start current			20 % – 200 % of the welding current
Start current time			0 – 10 sec.; not in 4-stroke mode
Twin pulse frequency			0,5 – 5 Hz; only in TwinPulse mode
Twin pulse current change			5 – 50 % of the welding current; only in TwinPulse mode
Twin pulse relation			20 % – 80 %; only in TwinPulse mode
Welding current			Adjustment range depends on the selected material-wire-gas combination

Transmig 320SP, 400SP, 500SP

Main Level	Level 1	Level 2	Remark
Downslope			10 – 990 A/sec.; not in electrode mode, only when downslope = on
Crater fill current			10 % – 200 % of the welding current; not in electrode mode, only when slope = on or in 4 stroke
Crater Fill time			0 – 10 sec.; not in electrode mode, only for slope = on
Wire burnback time			20 % – 300 % of the programmed value; not in electrode mode
Gas post-flow			20 % – 200 % of the programmed value; not in electrode mode
Arc length correction			60 % – 140 % of the programmed value
Inductor effect			20 % – 200 % of the programmed value; only in normal mode (short arc)
Arc dynamic (Arc Force)			0 % – 100 % of the programmed value; only in electrode mode
Job selection, indication of set and job name			Set and job name are indicated only in Tiptronic mode upon actuation of the „TT Enter“ push-button (47) or the „Tiptronic“ push-button (49)
	Edit mode for set and job name		Move the cursor with the ▼ and ▲ push-buttons (51) ; change the character with the pushbuttons (48) (+) and (44) (-)
Extras	1 Machine data	Operating system Master	Version number, operating system Master
		Operating system Process	Version number, operating system process
		Operating system DMRs	Version number, motor assembly
		Welding program version	Version number, welding programs
		Operating hour counter	Indication of the welding duration in h, min, sec
		Configuration	Machine type and the recognized power module (with max. current) are indicated alternately
	2 Diagnosis	Last error message	Indication of the last three error messages from the error memory (0 = last error, 2 = oldest error)
		Module temperatures	Temperatures of the power modules in °C
		Operating voltages	Indication of the operating voltages (15 V / 24 V) of the assembly DPMAPRO
		Flow rate, cooling unit	Indication of the coolant flow rate in l/min
	3 Language		Selection of the menu language
	4 Display contrast		Contrast setting of the LCD display
	5 Mode cooling system	0 normal	cooling unit switches on, as soon as an arc is ignited
		1 on	cooling unit runs constantly
		2 off	cooling unit is deactivated
	6 Lock function	0	All free
		1	Welding current, mode and Tiptronic on/off free
		2	Tiptronic on/off, job selection free
		3	All locked except menu selection, gas and pump test
	7 Arc length control	Voltage	correct arc length with rotary pulse encoder (58)
Wire		correct wire speed with rotary pulse encoder (58)	
8 Robot interface		Menu item is only visible when the machine is equipped with a robot interface (further details about setup/configuration see operation manual INT)	

6.01 Secondary Parameters (Menu Main Level)

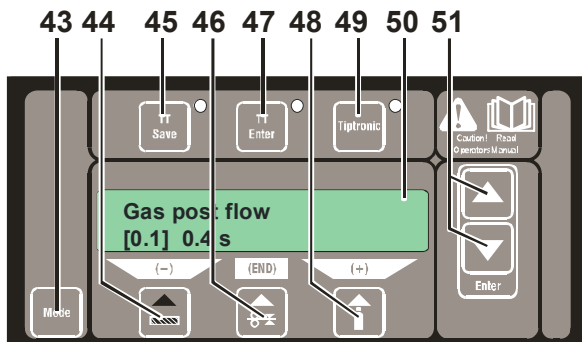

You can switch to the secondary parameters with ▼ and ▲ (51) push-buttons. The currently selected parameter is indicated in the display (50). The value in the square brackets is a standard or suggested value.

Push-button (44) (-) is used to reduce the indicated parameter and push-button (48) (+) is used to increase the value of the indicated parameter. Pressing the push-button (46) (END) saves the parameter and the system switches back to the material-wire-gas combination display.

Extras menu

In addition to the secondary parameters, the Extras menu item is also available; it offers the following functions:

Push-buttons (44) (-) and (48) (+) are used to switch between the menu items. The different entries of the menu items are called up by pressing the ▼ and ▲ push-buttons (51) at the same time. Switching between the individual entries is also possible here with the push-buttons (44) (-) and (48) (+). To return, press push-button (46) (END).

Tiptronic

The Tiptronic function provides you with 100 independent jobs (10 job set with 10 jobs each). A job stores all the settings and corrections on the operating panel.

The best way to use the Tiptronic function is to assign job numbers to frequently recurring welding tasks or save the settings which individual welders use specifically for "their" jobs.

Save/Programming jobs:

- Determine the optimal welding values.
- Press the "TT Save" button (45) (Save LED flashes).
- Select the target job number with the push-buttons (44) (-) and (48) (+) or with the smart torch rocker, and confirm with the "TT Enter" push-button (47) (if you do not press Enter, the Save LED goes out after 10 s after the last keystroke and the save operation is aborted).
- The Save and Enter LEDs flash briefly to confirm that programming is terminated.

Selecting jobs:

- Switch the Tiptronic function on by pressing "Tiptronic" (49) (associated LED comes on).
- Select the job number with the smart torch rocker (alternatively the job number can be selected with the push-buttons (44) (-) and (48) (+)).
- To exit the Tiptronic mode, press "Tiptronic" (49) (Tiptronic LED goes out). The parameters are reset to the values that existed before you switched on the Tiptronic mode.

Setting a job inactive:

- Switch the Tiptronic function on by pressing "Tiptronic" (49) (associated LED comes on).
- Select job number with the smart torch rocker (61) or with the push-buttons (44) (-) and (48) (+) (an active job is indicated in the smart torch display (60) and in digital multifunction display (54) with a decimal point between the job set and the job number).
- Hold the Enter push-button (47) pressed for two seconds (the decimal point in the smart torch display 60 and in the digital display (54) goes out).

Setting a job active:

- Switch the Tiptronic function on by pressing "Tiptronic" (49) (associated LED comes on).
- Select the job number with the push-buttons (44) (-) and (48) (+) (with an inactive job, the decimal point between job set and job number is missing).
- Hold the "TT Enter" push-button (47) pressed for two seconds (the decimal point between the job set and the job number lights up).

Re-saving/Re-programming jobs:

- Switch the Tiptronic function on by pressing "Tiptronic" (49) and select a job (see Selecting Jobs).
- Change the settings as required.
- Press the "TT Save" button (45) (Save LED flashes).
- Press "TT Enter" button (47) to confirm.
- The Save and Enter LEDs flash briefly to confirm that programming is terminated.

Copying jobs:

- Switch the Tiptronic function on by pressing "Tiptronic" (49) and select a job for copying (see Selecting Jobs).
- Press the "TT Save" button (45) (Save LED flashes).
- Select the target job number with the push-buttons (44) (-) and (48) (+) and confirm with the "TT Enter" push-button (47) (if the Enter push-button is not depressed, the Save LED goes out after 10 seconds and the job is not saved, ie copying the job is cancelled). If the target job number has not been occupied with a job yet, it is indicated by the display flashing.
- The Save and Enter LEDs flash briefly to confirm that programming is terminated. The user-defined job texts are also copied onto the new target job number.

Transmig 320SP, 400SP, 500SP

Assigning descriptive text to a job

Text can be assigned to each job in order to identify it more clearly.

- Switch on the Tiptronic function with the “Tiptronic” push-button **(49)**.
- Select the job number with the push-buttons **(44)** (-) and **(48)** (+).
- Press the ▼ and ▲ push-buttons **(51)** at the same time (a flashing cursor appears in the display **(50)**) in order to get into the edit mode.
- The cursor is moved with the ▼ and ▲ push-buttons **(51)**. At the end of the line, the cursor jumps to the respective next line.
- Select a character (number, letter or special character) with push-buttons **(44)** (-) and **(48)** (+).
- The edit mode is ended by pressing push-button **(46)** (END) or by pressing the ▼ and ▲ push-buttons **(51)** at the same time.
If you press the “Tiptronic” push-button **(49)** in edit mode (Tiptronic is switched off), then the text entries will not be saved.

Texts can be programmed both for the job set (upper line in display **(50)**) as well as for the job (bottom line in display **(50)**).

Special functions

Gas test

Pressing the ▲ push-button **(51)** then the “Gas type” push-button **(48)** at the same time activates the gas test function. The solenoid valve of the system is activated and the gas flow rate can be checked / adjusted. The function remains active for 30 seconds and is then ended automatically. By pushing the “Gas type” push-button **(48)** again, the gas test can be terminated.

Pump test

Pressing the ▲ push-button **(51)** then the “Material” push-button **(44)** at the same time activates the pump test function. The coolant pump is switched on and runs for approximately one minute. By pushing the “Material” push-button **(44)**, the pump test can be terminated.

Resetting adjustments

Pressing the ▲ push-button **(51)** and the “TT Enter” push-button **(47)** at the same time resets all secondary parameters to the Factory set values. When the Tiptronic mode is active, the settings of the current job are reset. All adjustment in the

Extras menu (language, display contrast, etc.) remain unchanged.

Code lock function

The lock function in menu Extras is secured with a code lock. A three-digit code must be entered before the lock function can be changed. Only after the correct code is entered, the lock function can be altered. After leaving the menu, a new code number can be set or the old code number is acknowledged. Code “000” is the default (factory setting) number.

Procedure:

- Switch to menu Extras, lock function
- Press button **(44)** (-) or **(48)** (+) question “change parameter ?” is displayed
- Acknowledge with button ▲ **(51)**
- Set three-digit code number with button **(44)** (-), **(48)** (+) or encoder **(53)**
- Acknowledge the code number with button ▲ **(51)**
- Set desired lock function number with buttons **(44)** (-) or **(48)** (+)
- Leave menu with button **(46)** (END)
- If requested, set a new code number with buttons **(44)** (-), **(48)** (+) or encoder **(53)**
- Acknowledge the code number with button ▲ **(51)**

Lift TIG welding (optional)

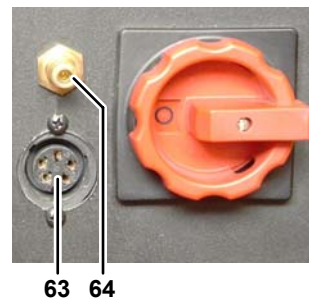

- Connect TIG torch to socket **(14)**
- Connect torch control-plug to socket
- Connect torch gas hose to gas connector
- Select TIG mode with mode button **(43)**

The following parameter can be set for TIG mode:

- start current / -time
- downslope
- end current / -time

Error codes

In case of a malfunction, an error code is indicated on the digital multifunction display (54) and the corresponding error description appears on the LCD display (50). As long as an error code is indicated, welding operation is not possible.

Code	Error description	Remark	Remedy
E00	<noP> (No welding program)	No welding parameters for the selected material-wire-gas combination	Choose a different material-wire-gas combination
E01	Thermal overload	The system has been overheated	Allow the system to cool down in standby; check the ventilation
E02	Mains over-voltage	Mains voltage too high	Check mains voltage
E03	Over-current	Output current too high	Notify an accredited CIGWELD Service Provider for repair
E04	Air-cooling error	Flow rate of air too low	Clean the air intake (9); check fan
E05	Faulty cooling circuit	No or too little flow rate of coolant	Check level of coolant and coolant filter
E06	Over-voltage	Output voltage too high	Notify an accredited CIGWELD Service Provider for repair
E07	EEPROM checksum error	Adjustment data faulty or not available	Switch system off and then on again
E08	Wire feed / tacho	Current input from feed motor too high No tacho signal available	Blow out torch package with compressed air and check wire feed unit
E09	Error v/a measuring	Faulty current / voltage measuring systems	Notify an accredited CIGWELD Service Provider for repair
E10	Torch socket / cable	Faulty torch switch cable or torch switch socket	Check torch
E11	Remote control socket	Faulty remote control or socket of remote control	Check remote control
E12	Communication process	Defective communication CAN-Bus (process)	Switch system off and then on again
E13	Error, temperature sensor	Thermo sensor not operative	Notify an accredited CIGWELD Service Provider for repair
E14	Supply voltage	Internal supply voltage too low	Check mains voltages
E16	Over-current protection 1	Allowable maximum power supply of power unit 1 too high	Notify an accredited CIGWELD Service Provider for repair
E18	Overload protection	Safety switch device for protection of electrical components	Allow the system to cool down in standby
E20	Over-voltage secondary	Output voltage too high	Notify an accredited CIGWELD Service Provider for repair
E21	Output voltage / current	Power unit delivers voltage / current without drive	Notify an accredited CIGWELD Service Provider for repair
E22	Mains under voltage 1	Mains voltage at power unit 1 too low	Check mains voltages
E23	Mains over-voltage	Mains voltage too high	Check mains voltages
E24	Over-current protection 2	Power supply of power unit 2 too high	Notify an accredited CIGWELD Service Provider for repair
E25	Power-module detection	Power unit not being recognized or unallowable combination of power units	Notify an accredited CIGWELD Service Provider for repair
E27	No program (DSP)	Welding programs faulty or not available	Notify an accredited CIGWELD Service Provider for repair
E30	Mains under-voltage 2	Mains voltage at power unit 2 too low	Check mains voltages
E31	Communication error	Faulty communication CAN-Bus (master)	Switch system off and then on again

SECTION 7: Basic MIG Welding

7.01 Types of Weld Transfer Modes

Dip transfer mode (short circuit arc)

This type of arc is especially suitable for thin materials and positional welding due to a relative cool welding pool welded with very short arc, low arc voltage and low current. The surface tension of the welding pool helps to draw the molten metal into the weld pool and to reignite the arc. This cycle is repeated again and again so the short circuit and the arcing period are constantly alternating.



The transition from the short circuit to spray arc depends on the wire diameter and the gas mixture.

Transitional arc

The transitional arc is especially suitable for medium thickness sheet metals and for vertical-down welding. The transfer of the electrode to the workpiece takes place partly in short circuit and in free flight. Due to fewer short circuits, the welding pool is hotter than at the short circuit arc. Welding with transitional arc provides higher electrode melt rate and is more economic than welding at short circuit arc.

Long arc

Long arcs are typically at a higher ampere range under carbon dioxide and gases with a high CO₂ content. It is not particularly suitable for positional welding. In this type of arc large drops are formed which falls into the welding pool mainly by force of gravity. This results in occasionally short circuits occurring, which increases the current at the moment of the short circuit and high spatter levels when the arc is reignited.

Spray arc

The spray arc is not suitable for positional welding, due to the extremely liquid nature of the weld pool. The spray arc forms by welding at the higher amperage using inert gas or mixtures with high argon content. The most typical characteristic of the spray arc is the transfer of extremely fine molten metal droplets across the arc.

Working range at MIG welding

Wire diameter	Long arc / Spray arc		Transitional arc		Short circuit arc	
	A	V	A	V	A	V
0.8	140... 180	23... 28	110... 150	18... 22	50... 130	14... 18
1.0	180... 250	24... 30	130... 200	18... 24	70... 160	16... 19
1.2	220... 320	25... 32	170... 250	19... 26	120... 200	17... 20
1.6	260... 320	26... 34	200... 300	22... 28	150... 200	18... 21

Favourable welding characteristic are only possible if voltage and current are correctly adjusted.

CO₂ requires an arc voltage approximately 3 V higher than gas mixtures with a high argon content.

7.02 Holding and Manipulating the Torch

NOTE 4

Metal shielded gas welding can be welded in all positions: horizontal, vertical-down, vertical-up, overhead and in horizontal-vertical position.

When horizontal welding, hold the torch vertical to the workpiece (neutral torch position) or up to 30° “pushing” the torch. For best depth of penetration and shielding gas coverage hold the torch in the neutral position. Please note that if the torch is tilted to far, it is possible that air will be sucked into the shielded gas and may result in porosity.

For vertical or overhead welding a slight pushing motion is required. Vertical down welding is most used for thin materials, hold the torch at the neutral or slightly “dragging” position. Some experience is required as the weld pool could run ahead of the arc and cause weld defects. There is a danger of lacks of fusion with thicker material due to the weld pool being very liquid due to high voltage.

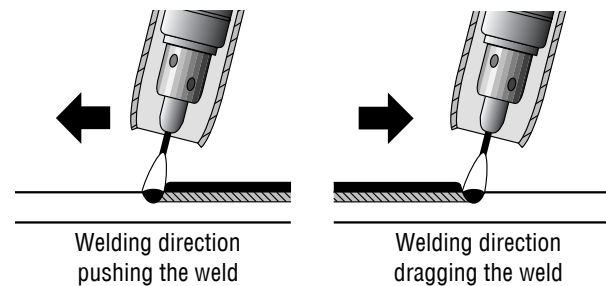

Avoid extreme side to side movements to avoid the weld pool being dammed up in front of the arc. This could cause lacks of fusion due to the weld pool flows ahead of the welding arc. The side to side motion should only be used as wide as is necessary to reach both sides of the joint. If the joint is too wide you should weld two parallel weld beads.

When vertical-up welding, the side to side motion should follow the shape of an open triangle.

Length of the arc

Welding with a longer arc reduces the penetration, the welding bead is wide and flat with increased spattering. The welding material is transferred with slightly larger drops than welding with a shorter arc. A longer arc is useful for welding a fillet weld to form a flat or concave seam.

Welding with a shorter arc (at the same amperage) increases the penetration, the welding bead is narrow and high with reduced spattering. The welding material is transferred with smaller droplets.

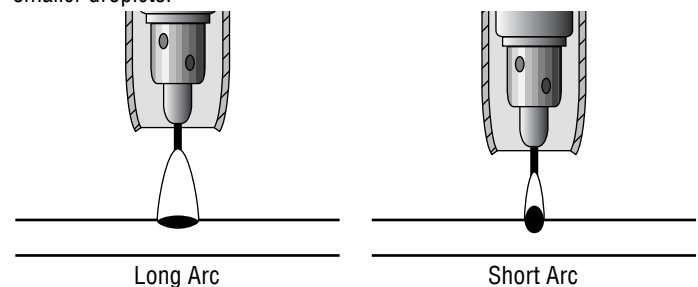

Length of the wire electrode

The distance between the torch and the workpiece should be 10 – 12 times the diameter of the wire. Altering the distance of the torch will influence the electrode stick out.

A longer electrode stick out reduces the amperage and the penetration.

A shorter electrode stick out increases the amperage if the wire-feed speed remains the same.

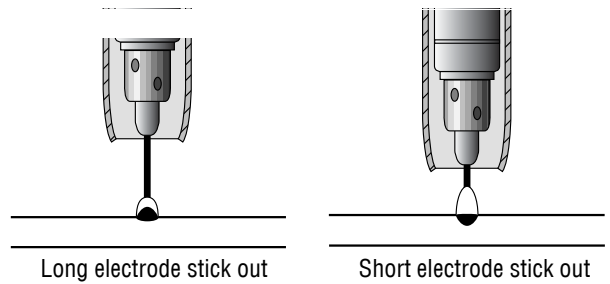

Material transfer

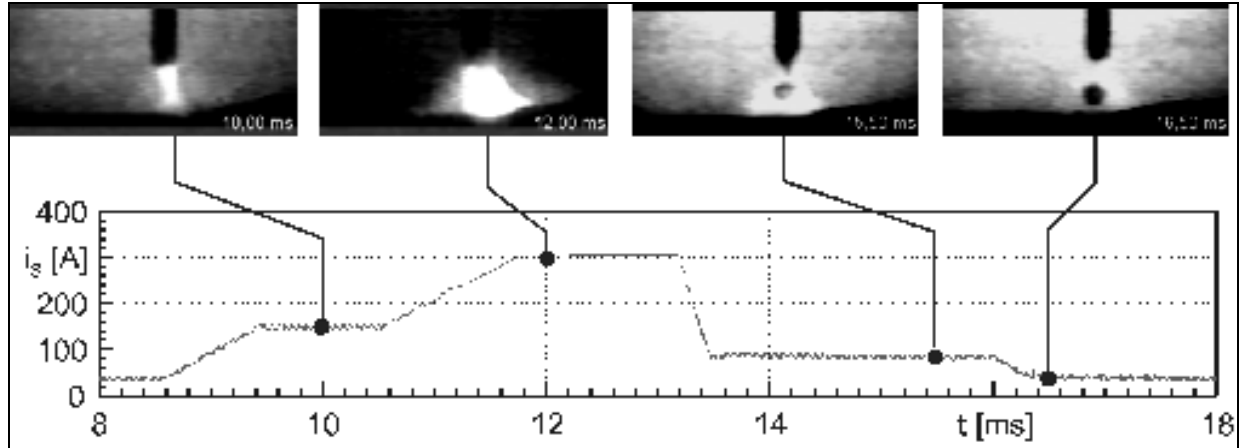

○ Benefits:

- Controlled, short-circuit-proof material transfer without spatter
- Low thermal transfer due to low primary current

○ Disadvantages:

- Only shielding gases with low CO₂ content can be used

SECTION 8: Basics of Pulsed Arc Welding

Current and voltage pulses

Material transfer is achieved by current and voltage pulses controlled at the same rate as the pulse frequency. The arc power is changed by the ratio between background and pulses current, the pulse duty cycle and the pulse frequency.

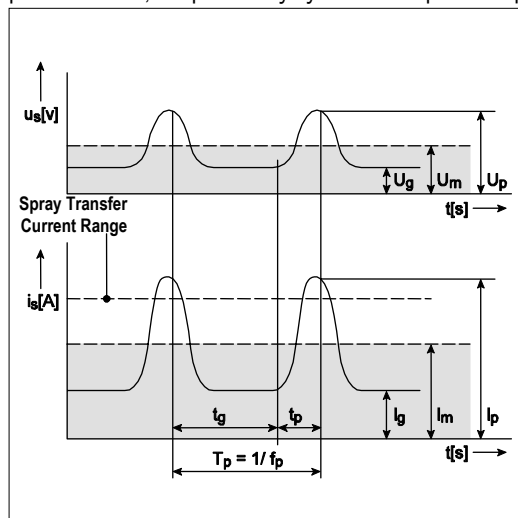

Forces acting during material transfer

A number of forces come into play which influences the resulting molten metal drop formation and separation.

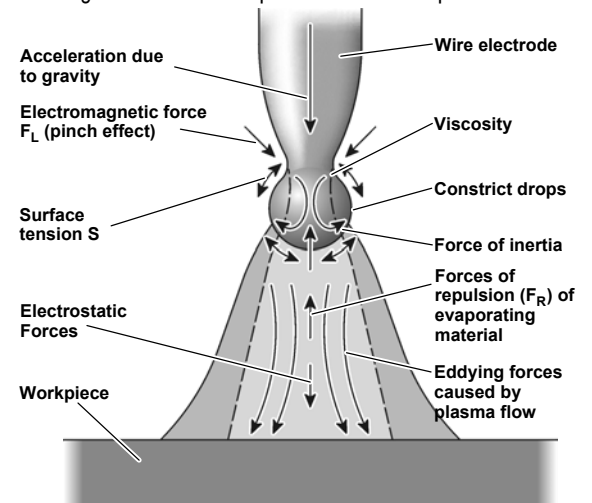

☞ The main force components for separating the drops are electromagnetic force (pinch effect).

Welding parameters

Pulse period t_p

The pulse period for separating the droplet is between 1.5 and 3.0 milli-seconds depending on wire diameter and the pulse current setting I_p .

If the pulse period is too long, material transfer only takes place during the pulse phase.

Arc formation and drop rate can be affected by additional pulse stages.

Pulse voltage U_p and pulse current I_p

Since welding with pulsed arc is based on the temporary utilisation of the pinch effect, the drop-separating pulse current must always be large enough to exceed critical current intensity depending on wire diameter, wire material and shielding gas composition, etc. If this value is not achieved, material transfer takes place completely or partially in the short circuit with possible spatter.

Wire feed speed v_D and pulse frequency f_p

The main condition for a controlled material transfer with one drop per pulse is to set a defined drop volume. The volume of the melted drop must then be identical with the volume of the wire electrode fed in each pulse period. The necessary wire feed speed v_D results from the product of pulse frequency f_p and the wire length "L" melted in each pulse period. From this relationship you see that a change in wire feed speed requires a linear change in pulse frequency. A rise in electrode melt rate by increasing wire feed speed needs a higher pulse frequency. The objective drop diameter should be about 1.2 mm with a wire diameter of 1.2 mm.

Primary current

Arc length ionisation must be maintained during the primary current phase, whose period results from the selected frequency and pulse period. This requires currents ranging between 25 and 80 A depending on wire diameter, material and material thickness. The primary current can also be used to affect the arc and material transfer. At a constant ratio of wire feed speed and pulse frequency, the arc length can be changed by varying the primary current and the associated voltage. Reducing the primary current causes a shorter arc. This can be used to counteract arc deflection with fillet welds or at high welding rates.

The time of drop separation can be affected by varying the ratio of primary current to pulse current. Normally the objective is to separate the drop just after the current pulse in the primary current phase (in the third pulse current phase).

This can be achieved by increasing the primary current and reducing the pulse current at the same time. Remember that excessively high primary current will melt the free wire end too quickly. This will form very large drops which can lead to spatter during the transition to the welding pool.

Pulse MIG applications

The main application for pulse MIG is for precision MIG welding of aluminium, stainless steel, steel and other weldable materials.

- Spray transfer welding permitted at lower-than-normal average weld currents.
- No spatter or undercut in the majority of welding applications.
- Precise control of welding power, to assure bead shape and root penetration rivalling TIG welding.
- High energy arc produced, that virtually eliminates the risk of lack of fusion.
- Improved arc control for out-of-position welding and more effective welding of thin materials, with all the advantages of spray transfer.
- Optimised pulse programs for gas/wire combinations
- TwinPulse® capabilities.
- Exceptional out-of-position welding for non-ferrous materials, including aluminium.
- Effortless TIG-like weld appearance on aluminium and stainless steel
- Deeper weld penetration
- Accurate penetration on sheet metal
- Superior welding characteristics on hard-facing and high-alloy steels
- The ability to use larger-than-normal diameter wires on thin base material, providing a cost saving on wire
- Spray arc welding vertical up, giving smoother welds, better control and deeper penetration
- Improved edge wetting in synergic pulse mode

At the lower end of the performance range the pulsed arc cannot fully replace the dip transfer. The reason is the continuous arc that occurs in the primary current phase. This phenomenon does not exist with the short-circuiting arc. An exception to this is when welding aluminium and aluminium alloys. Normally, these materials can only be reliably welded using a pulsed arc. In the upper performance range, the pulsed arc is preferable to the sprayer arc, in particular for welding aluminium materials and high-alloy steels.

SECTION 9: Care and Maintenance



WARNING 7

There are extremely dangerous voltages and power levels present inside this product. Do not attempt to open or repair unless you are an Accredited CIGWELD Service Agent and you have had training in power measurements and troubleshooting techniques.

The machine requires minimum care and maintenance. Only a few items should be checked to ensure a trouble free long term operation:

- Check the mains plug, mains cable, and the welding torch as well as the Negative connection for damage from time to time.
- Once or twice a year please clean the machine with dry low compressed air. Switch off the machine and pull out the plug first. Open the case of the machine and clean also inside - please avoid blowing directly onto electronic parts – they could be damaged.

For machines with integrated coolant cooled machines:

- Check if the torch connections are coolant tight.
- Check the level of the cooling fluid and refill original Thermadyne cooling fluid, if required.
- Observe the quantity of the coolant return in the cooling reservoir to avoid damage of the torch or hose package (no claims under warranty possible).

9.01 Troubleshooting Guide

Symptom	Cause	Remedy
Torch too hot	Insufficient coolant through flow due to pollution in coolant	Flush the coolant hoses of the torch in opposite direction
	Contact tip is not tight or the wrong size for the wire used	Check it
No function when torch button is pressed	The torch connection is not tight	Tighten it
	No connection of the control cable in the torch hose	Check and change if necessary
	Thermal overload of the unit and thermal protection operates	Allow unit to cool down at no load
Irregular wire feeding or wire welds to the contact tip	Wire electrode is tight at the spool	Check and change if necessary
	Burr at the start of wire	Cut the burr off the wire
Irregular wire feeding or no wire feeding	In-correct contact pressure at the wire-feed rolls	Adjust it as described in the manual
	Torch defect	Check and change if necessary
	No intermediate guide or it is dirty	Install or clean the intermediate guide
	Poor quality of welding wire	Check and change if necessary
	Rust formation at the welding wire	Check and change if necessary
	Torch liner is dirty inside	Disconnect the torch from the machine, screw off the contact tip and clean the liner with compressed air
	Torch liner is dejected	Check and change if necessary
Unit switches off	Duty cycle overloaded	Allow the machine to cool down
	Poor cooling of units internal parts	Check the air in and outlet
Cooler or hoses defect or pump is damaged	Frozen systems due to low concentration of recommended coolant in re-circulator	Contact the nearest service facility
Arc or short circuit between contact tip and gas nozzle	Spatter built up inside the gas nozzle	Remove it with special pliers
Unstable arc	Wrong diameter of contact tip or worn out	Change contact tip
The <i>Control Panel</i> is completely blank	Primary power phase missing	Check the unit at another power outlet. Check power cable and mains fuses/circuit breakers
No shielded gas	Gas cylinder empty	Replace it
	Defect torch	Check and replace it
	Gas regulator dirty or defect	Check and replace it
	Valve of gas cylinder defect	Replace the gas cylinder
Shielded gas switches not off	Valve of gas cylinder dirty or does not close	Remove torch and gas regulator and clean it with compressed air

9.01 Troubleshooting Guide

Symptom	Cause	Remedy
Not sufficient shielded gas	Incorrect adjustment of shielded gas	Increase shielding gas flow rate as described in the manual
	Dirty gas regulator	Check valve
	Torch, gas hose blocked or not air-tight	Check and change if necessary
	Shielded gas is blow away from draught	Avoid draught
Less welding performance	Phase missing	Check the unit at another power outlet. Check power cable and mains fuses/circuit breakers
	Poor Work lead connection	Ensure good electrical contact between Work clamp and workpiece
	Work lead plug not tightened	Fasten work lead by turning the plug to the right
	Defective torch	Repair or replace it
Hot plug of work lead	Plug was not tightened by turning to the right	Check
Higher wire wear out at wire-feeding unit	Wire rolls does not fit to the wire diameter	Install right wire rolls
	Wrong contact pressure at wire feeding	Adjust as described at the manual

9.02 Options

Pocket Pendant remote control RC 20

For correctional adjustments of the wire feed speed, level and job with the RC 20 Remote Hand Pendant.

Control Panel remote control HR911

Includes 5 m power supply cable and CAN-BUS plug. In conjunction with wire feeders without operation panel or Robotic wire feeder, the HR911 must be used as operating panel.

Robot interface

Interface for connection to automated welding appliances or welding robots.

Push pull torch

At longer torches as 5 m it is recommended to use a Push pull torch. Due to an additional wire-feed motor at the torch a continuous wire feed is provided.

Push pull Interface Option

For control of a Thermadyne push pull torch.

Instrument set DS - V/A-Meter

Additional digital voltmeter and ammeter for indication of the actual values of welding current and welding voltage, either in the power source or in the wire feeder.

Suspension fixture





Fixture for suspended mounting of the workshop wire feeder.

Interconnection Assembly

Prolongation between power source and wire-feed case from 1 or 10 m.

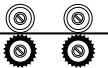
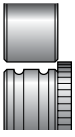
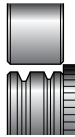
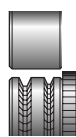
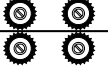
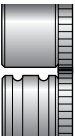
Lift TIG option

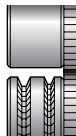
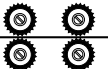
TIG welding with additional TIG torch.

Description		Use	Feedroll for Aluminium Wire	Feedroll for Solid Wire	Feedroll for Flux Cored Wire
Standard		Standard at 4 rolls feeding units. Due to the straightening effect of the feed rolls system, less wire friction in the torch. For use with thicker or hard wires. Knurled rolls ideal for flux cored wires.			
Double drive		Straightening effect and double drive. Less contact pressure due to double drive provides less wire distortion. For use with thicker and hard wires with longer torch lengths. Knurled rolls ideal for flux cored wires.			
Wire-feed rolls with Double grooves		Rolls with double groove (above and below). No wire distortion. Ideal for soft wires, ie Aluminium, bronze, copper, etc.			

Appendix - mounting torch holder

