

# LN-25 PORTABLE CV/CC SEMIAUTOMATIC WIRE FEEDER

IM620-B

September, 2005

|  |       |       |
|--|-------|-------|
| For use with machines having Code Number | 10556 | 11144 |
|  | 10557 | 11145 |
|  | 10558 | 11282 |
|  |       | 11283 |

## Safety Depends on You

Lincoln arc welding and cutting equipment is designed and built with safety in mind. However, your overall safety can be increased by proper installation ... and thoughtful operation on your part. **DO NOT INSTALL, OPERATE OR REPAIR THIS EQUIPMENT WITHOUT READING THIS MANUAL AND THE SAFETY PRECAUTIONS CONTAINED THROUGHOUT.** And, most importantly, think before you act and be careful.

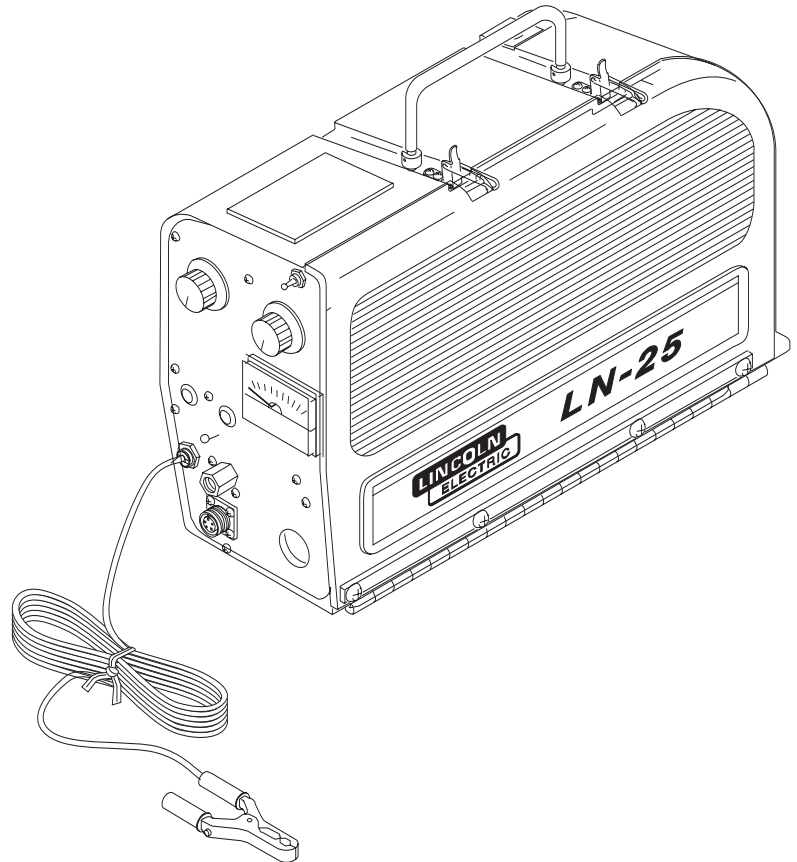

## OPERATING MANUAL



**LINCOLN**<sup>®</sup>  
**ELECTRIC**

Copyright © 2005 Lincoln Global Inc.

• World's Leader in Welding and Cutting Products •  
• Sales and Service through Subsidiaries and Distributors Worldwide •  
Cleveland, Ohio 44117-1199 U.S.A. TEL: 216.481.8100 FAX: 216.486.1751 WEB SITE: [www.lincolnelectric.com](http://www.lincolnelectric.com)

## ! WARNING

### ! CALIFORNIA PROPOSITION 65 WARNINGS !

Diesel engine exhaust and some of its constituents are known to the State of California to cause cancer, birth defects, and other reproductive harm.

The Above For Diesel Engines

The engine exhaust from this product contains chemicals known to the State of California to cause cancer, birth defects, or other reproductive harm.

The Above For Gasoline Engines

**ARC WELDING CAN BE HAZARDOUS. PROTECT YOURSELF AND OTHERS FROM POSSIBLE SERIOUS INJURY OR DEATH. KEEP CHILDREN AWAY. PACEMAKER WEARERS SHOULD CONSULT WITH THEIR DOCTOR BEFORE OPERATING.**

Read and understand the following safety highlights. For additional safety information, it is strongly recommended that you purchase a copy of "Safety in Welding & Cutting - ANSI Standard Z49.1" from the American Welding Society, P.O. Box 351040, Miami, Florida 33135 or CSA Standard W117.2-1974. A Free copy of "Arc Welding Safety" booklet E205 is available from the Lincoln Electric Company, 22801 St. Clair Avenue, Cleveland, Ohio 44117-1199.

**BE SURE THAT ALL INSTALLATION, OPERATION, MAINTENANCE AND REPAIR PROCEDURES ARE PERFORMED ONLY BY QUALIFIED INDIVIDUALS.**



### FOR ENGINE powered equipment.

1.a. Turn the engine off before troubleshooting and maintenance work unless the maintenance work requires it to be running.



1.b. Operate engines in open, well-ventilated areas or vent the engine exhaust fumes outdoors.



1.c. Do not add the fuel near an open flame welding arc or when the engine is running. Stop the engine and allow it to cool before refueling to prevent spilled fuel from vaporizing on contact with hot engine parts and igniting. Do not spill fuel when filling tank. If fuel is spilled, wipe it up and do not start engine until fumes have been eliminated.

1.d. Keep all equipment safety guards, covers and devices in position and in good repair. Keep hands, hair, clothing and tools away from V-belts, gears, fans and all other moving parts when starting, operating or repairing equipment.

1.e. In some cases it may be necessary to remove safety guards to perform required maintenance. Remove guards only when necessary and replace them when the maintenance requiring their removal is complete. Always use the greatest care when working near moving parts.



1.f. Do not put your hands near the engine fan. Do not attempt to override the governor or idler by pushing on the throttle control rods while the engine is running.

1.g. To prevent accidentally starting gasoline engines while turning the engine or welding generator during maintenance work, disconnect the spark plug wires, distributor cap or magneto wire as appropriate.



1.h. To avoid scalding, do not remove the radiator pressure cap when the engine is hot.



### ELECTRIC AND MAGNETIC FIELDS may be dangerous

2.a. Electric current flowing through any conductor causes localized Electric and Magnetic Fields (EMF). Welding current creates EMF fields around welding cables and welding machines

2.b. EMF fields may interfere with some pacemakers, and welders having a pacemaker should consult their physician before welding.

2.c. Exposure to EMF fields in welding may have other health effects which are now not known.

2.d. All welders should use the following procedures in order to minimize exposure to EMF fields from the welding circuit:

2.d.1. Route the electrode and work cables together - Secure them with tape when possible.

2.d.2. Never coil the electrode lead around your body.

2.d.3. Do not place your body between the electrode and work cables. If the electrode cable is on your right side, the work cable should also be on your right side.

2.d.4. Connect the work cable to the workpiece as close as possible to the area being welded.

2.d.5. Do not work next to welding power source.

Mar '95



### ELECTRIC SHOCK can kill.

3.a. The electrode and work (or ground) circuits are electrically "hot" when the welder is on. Do not touch these "hot" parts with your bare skin or wet clothing. Wear dry, hole-free gloves to insulate hands.

3.b. Insulate yourself from work and ground using dry insulation. Make certain the insulation is large enough to cover your full area of physical contact with work and ground.

**In addition to the normal safety precautions, if welding must be performed under electrically hazardous conditions (in damp locations or while wearing wet clothing; on metal structures such as floors, gratings or scaffolds; when in cramped positions such as sitting, kneeling or lying, if there is a high risk of unavoidable or accidental contact with the workpiece or ground) use the following equipment:**

- Semiautomatic DC Constant Voltage (Wire) Welder.
- DC Manual (Stick) Welder.
- AC Welder with Reduced Voltage Control.

3.c. In semiautomatic or automatic wire welding, the electrode, electrode reel, welding head, nozzle or semiautomatic welding gun are also electrically "hot".

3.d. Always be sure the work cable makes a good electrical connection with the metal being welded. The connection should be as close as possible to the area being welded.

3.e. Ground the work or metal to be welded to a good electrical (earth) ground.

3.f. Maintain the electrode holder, work clamp, welding cable and welding machine in good, safe operating condition. Replace damaged insulation.

3.g. Never dip the electrode in water for cooling.

3.h. Never simultaneously touch electrically "hot" parts of electrode holders connected to two welders because voltage between the two can be the total of the open circuit voltage of both welders.

3.i. When working above floor level, use a safety belt to protect yourself from a fall should you get a shock.

3.j. Also see Items 6.c. and 8.



### ARC RAYS can burn.

4.a. Use a shield with the proper filter and cover plates to protect your eyes from sparks and the rays of the arc when welding or observing open arc welding. Headshield and filter lens should conform to ANSI Z87. 1 standards.

4.b. Use suitable clothing made from durable flame-resistant material to protect your skin and that of your helpers from the arc rays.

4.c. Protect other nearby personnel with suitable, non-flammable screening and/or warn them not to watch the arc nor expose themselves to the arc rays or to hot spatter or metal.



### FUMES AND GASES can be dangerous.

5.a. Welding may produce fumes and gases hazardous to health. Avoid breathing these fumes and gases. When welding, keep your head out of the fume. Use enough ventilation and/or exhaust at the arc to keep

fumes and gases away from the breathing zone. **When welding with electrodes which require special ventilation such as stainless or hard facing (see instructions on container or MSDS) or on lead or cadmium plated steel and other metals or coatings which produce highly toxic fumes, keep exposure as low as possible and below Threshold Limit Values (TLV) using local exhaust or mechanical ventilation. In confined spaces or in some circumstances, outdoors, a respirator may be required. Additional precautions are also required when welding on galvanized steel.**

5.b. Do not weld in locations near chlorinated hydrocarbon vapors coming from degreasing, cleaning or spraying operations. The heat and rays of the arc can react with solvent vapors to form phosgene, a highly toxic gas, and other irritating products.

5.c. Shielding gases used for arc welding can displace air and cause injury or death. Always use enough ventilation, especially in confined areas, to insure breathing air is safe.

5.d. Read and understand the manufacturer's instructions for this equipment and the consumables to be used, including the material safety data sheet (MSDS) and follow your employer's safety practices. MSDS forms are available from your welding distributor or from the manufacturer.

5.e. Also see item 1.b.

Mar '95

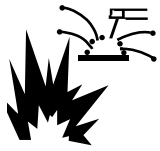

### WELDING SPARKS can cause fire or explosion.

6.a. Remove fire hazards from the welding area. If this is not possible, cover them to prevent the welding sparks from starting a fire.

Remember that welding sparks and hot materials from welding can easily go through small cracks and openings to adjacent areas. Avoid welding near hydraulic lines. Have a fire extinguisher readily available.

- 6.b. Where compressed gases are to be used at the job site, special precautions should be used to prevent hazardous situations. Refer to "Safety in Welding and Cutting" (ANSI Standard Z49.1) and the operating information for the equipment being used.
- 6.c. When not welding, make certain no part of the electrode circuit is touching the work or ground. Accidental contact can cause overheating and create a fire hazard.
- 6.d. Do not heat, cut or weld tanks, drums or containers until the proper steps have been taken to insure that such procedures will not cause flammable or toxic vapors from substances inside. They can cause an explosion even though they have been "cleaned". For information, purchase "Recommended Safe Practices for the Preparation for Welding and Cutting of Containers and Piping That Have Held Hazardous Substances", AWS F4.1 from the American Welding Society (see address above).
- 6.e. Vent hollow castings or containers before heating, cutting or welding. They may explode.
- 6.f. Sparks and spatter are thrown from the welding arc. Wear oil free protective garments such as leather gloves, heavy shirt, cuffless trousers, high shoes and a cap over your hair. Wear ear plugs when welding out of position or in confined places. Always wear safety glasses with side shields when in a welding area.
- 6.g. Connect the work cable to the work as close to the welding area as practical. Work cables connected to the building framework or other locations away from the welding area increase the possibility of the welding current passing through lifting chains, crane cables or other alternate circuits. This can create fire hazards or overheat lifting chains or cables until they fail.
- 6.h. Also see item 1.c.

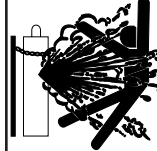

### CYLINDER may explode if damaged.

7.a. Use only compressed gas cylinders containing the correct shielding gas for the process used and properly operating regulators designed for the gas and pressure used. All hoses, fittings, etc. should be suitable for the application and maintained in good condition.

- 7.b. Always keep cylinders in an upright position securely chained to an undercarriage or fixed support.
- 7.c. Cylinders should be located:
  - Away from areas where they may be struck or subjected to physical damage.
  - A safe distance from arc welding or cutting operations and any other source of heat, sparks, or flame.
- 7.d. Never allow the electrode, electrode holder or any other electrically "hot" parts to touch a cylinder.
- 7.e. Keep your head and face away from the cylinder valve outlet when opening the cylinder valve.
- 7.f. Valve protection caps should always be in place and hand tight except when the cylinder is in use or connected for use.
- 7.g. Read and follow the instructions on compressed gas cylinders, associated equipment, and CGA publication P-1, "Precautions for Safe Handling of Compressed Gases in Cylinders," available from the Compressed Gas Association 1235 Jefferson Davis Highway, Arlington, VA 22202.



### FOR ELECTRICALLY powered equipment.

- 8.a. Turn off input power using the disconnect switch at the fuse box before working on the equipment.
- 8.b. Install equipment in accordance with the U.S. National Electrical Code, all local codes and the manufacturer's recommendations.
- 8.c. Ground the equipment in accordance with the U.S. National Electrical Code and the manufacturer's recommendations.

Mar '95

## PRÉCAUTIONS DE SÛRETÉ

Pour votre propre protection lire et observer toutes les instructions et les précautions de sûreté spécifiques qui paraissent dans ce manuel aussi bien que les précautions de sûreté générales suivantes:

### Sûreté Pour Soudage A L'Arc

1. Protégez-vous contre la secousse électrique:
  - a. Les circuits à l'électrode et à la pièce sont sous tension quand la machine à souder est en marche. Eviter toujours tout contact entre les parties sous tension et la peau nue ou les vêtements mouillés. Porter des gants secs et sans trous pour isoler les mains.
  - b. Faire très attention de bien s'isoler de la masse quand on soude dans des endroits humides, ou sur un plancher métallique ou des grilles métalliques, principalement dans les positions assis ou couché pour lesquelles une grande partie du corps peut être en contact avec la masse.
  - c. Maintenir le porte-électrode, la pince de masse, le câble de soudage et la machine à souder en bon et sûr état de fonctionnement.
  - d. Ne jamais plonger le porte-électrode dans l'eau pour le refroidir.
  - e. Ne jamais toucher simultanément les parties sous tension des porte-électrodes connectés à deux machines à souder parce que la tension entre les deux pinces peut être le total de la tension à vide des deux machines.
  - f. Si on utilise la machine à souder comme une source de courant pour soudage semi-automatique, ces précautions pour le porte-électrode s'appliquent aussi au pistolet de soudage.
2. Dans le cas de travail au dessus du niveau du sol, se protéger contre les chutes dans le cas où on recoit un choc. Ne jamais enrouler le câble-électrode autour de n'importe quelle partie du corps.
3. Un coup d'arc peut être plus sévère qu'un coup de soliel, donc:
  - a. Utiliser un bon masque avec un verre filtrant approprié ainsi qu'un verre blanc afin de se protéger les yeux du rayonnement de l'arc et des projections quand on soude ou quand on regarde l'arc.
  - b. Porter des vêtements convenables afin de protéger la peau de soudeur et des aides contre le rayonnement de l'arc.
  - c. Protéger l'autre personnel travaillant à proximité au soudage à l'aide d'écrans appropriés et non-inflammables.
4. Des gouttes de laitier en fusion sont émises de l'arc de soudage. Se protéger avec des vêtements de protection libres de l'huile, tels que les gants en cuir, chemise épaisse, pantalons sans revers, et chaussures montantes.
5. Toujours porter des lunettes de sécurité dans la zone de soudage. Utiliser des lunettes avec écrans latéraux dans les zones où l'on pique le laitier.
6. Eloigner les matériaux inflammables ou les recouvrir afin de prévenir tout risque d'incendie dû aux étincelles.

7. Quand on ne soude pas, poser la pince à un endroit isolé de la masse. Un court-circuit accidentel peut provoquer un échauffement et un risque d'incendie.
8. S'assurer que la masse est connectée le plus près possible de la zone de travail qu'il est pratique de le faire. Si on place la masse sur la charpente de la construction ou d'autres endroits éloignés de la zone de travail, on augmente le risque de voir passer le courant de soudage par les chaînes de levage, câbles de grue, ou autres circuits. Cela peut provoquer des risques d'incendie ou d'échauffement des chaînes et des câbles jusqu'à ce qu'ils se rompent.
9. Assurer une ventilation suffisante dans la zone de soudage. Ceci est particulièrement important pour le soudage de tôles galvanisées plombées, ou cadmiées ou tout autre métal qui produit des fumées toxiques.
10. Ne pas souder en présence de vapeurs de chlore provenant d'opérations de dégraissage, nettoyage ou pistolage. La chaleur ou les rayons de l'arc peuvent réagir avec les vapeurs du solvant pour produire du phosgène (gas fortement toxique) ou autres produits irritants.
11. Pour obtenir de plus amples renseignements sur la sûreté, voir le code "Code for safety in welding and cutting" CSA Standard W 117.2-1974.

## PRÉCAUTIONS DE SÛRETÉ POUR LES MACHINES À SOUDER À TRANSFORMATEUR ET À REDRESSEUR

1. Relier à la terre le chassis du poste conformément au code de l'électricité et aux recommandations du fabricant. Le dispositif de montage ou la pièce à souder doit être branché à une bonne mise à la terre.
2. Autant que possible, l'installation et l'entretien du poste seront effectués par un électricien qualifié.
3. Avant de faire des travaux à l'intérieur de poste, la débrancher à l'interrupteur à la boîte de fusibles.
4. Garder tous les couvercles et dispositifs de sûreté à leur place.

Mar. '93

# Thank You

for selecting a **QUALITY** product by Lincoln Electric. We want you to take pride in operating this Lincoln Electric Company product •• as much pride as we have in bringing this product to you!

## **Please Examine Carton and Equipment For Damage Immediately**

When this equipment is shipped, title passes to the purchaser upon receipt by the carrier. Consequently, Claims for material damaged in shipment must be made by the purchaser against the transportation company at the time the shipment is received.

Please record your equipment identification information below for future reference. This information can be found on your machine nameplate.

Product \_\_\_\_\_

Model Number \_\_\_\_\_

Code Number or Date Code \_\_\_\_\_

Serial Number \_\_\_\_\_

Date Purchased \_\_\_\_\_

Where Purchased \_\_\_\_\_

Whenever you request replacement parts or information on this equipment, always supply the information you have recorded above. The code number is especially important when identifying the correct replacement parts.

## **On-Line Product Registration**

- Register your machine with Lincoln Electric either via fax or over the Internet.

- For faxing: Complete the form on the back of the warranty statement included in the literature packet accompanying this machine and fax the form per the instructions printed on it.
- For On-Line Registration: Go to our **WEB SITE at [www.lincolnelectric.com](http://www.lincolnelectric.com)**. Choose "Quick Links" and then "Product Registration". Please complete the form and submit your registration.

**Read this Operators Manual completely** before attempting to use this equipment. Save this manual and keep it handy for quick reference. Pay particular attention to the safety instructions we have provided for your protection. The level of seriousness to be applied to each is explained below:

### **WARNING**

This statement appears where the information **must** be followed **exactly** to avoid **serious personal injury** or **loss of life**.

### **CAUTION**

This statement appears where the information **must** be followed to avoid **minor personal injury** or **damage to this equipment**.



# TABLE OF CONTENTS

---

|  |                    |
|--|--------------------|
| <b>SAFETY .....</b>  | <b>i-iv</b>        |
| <b>INSTALLATION .....</b>  | <b>SECTION A</b>   |
| Technical Specifications .....                                   | A-1                |
| Safety Precautions .....   | A-2                |
| Power Source Connections .....                                   | A-2                |
| Gun Cable Connection to Feeder .....                             | A-3                |
| Weld Cable Connection .....                                      | A-4                |
| Electrode Cable Connection .....                                 | A-4                |
| Work Cable Connection .....                                      | A-4                |
| Wire Feed Drive Roll and Guide Tube Kits .....                   | A-4                |
| <b>OPERATION .....</b>   | <b>SECTION B</b>   |
| Safety Precautions .....   | B-1                |
| General Description .....  | B-1                |
| Recommended Processes and Equipment .....                        | B-1                |
| Welding Capability .....   | B-1                |
| Controls and Settings .....                                      | B-2                |
| Sequence of Operation .....                                      | B-4                |
| Loading Electrode .....  | B-4                |
| Loading Wire Drive .....   | B-5                |
| Idle Roll Pressure Setting .....                                 | B-5                |
| Presetting Wire Feed Speed .....                                 | B-6                |
| Making a Weld .....  | B-7                |
| Procedure at End of Coil .....                                   | B-8                |
| Automatic Protection Shutdown .....                              | B-8                |
| <b>ACCESSORIES .....</b>   | <b>SECTION C</b>   |
| LN-25 Option Chart .....   | C-1                |
| Options and Accessories .....                                    | C-2                |
| K430-2 Gas Solenoid Kit .....                                    | C-2                |
| K434-1 Gas Flow Timer Kit .....                                  | C-2                |
| K460-1 Pulse Power Adapter Kit .....                             | C-3                |
| K461 Pulse Power Control Cable Assembly .....                    | C-3                |
| K443-2, K443-3 LN-25 Contactor Kits .....                        | C-3                |
| Remote Output Control Options and Control Cable Assemblies ..... | C-3                |
| K431-1 Remote Output Control Kit .....                           | C-3                |
| K433 Power Source Remote Box .....                               | C-4                |
| K432 Remote Control Cable Assembly .....                         | C-4                |
| K439 Remote Extension Cable Assembly .....                       | C-4                |
| K624-1 42V Remote Output Control Module .....                    | C-4                |
| K625, K626, K626 Remote Control Cable Assembly .....             | C-4                |
| K444, K444-1 or K444-2 Remote Voltage Control Kit .....          | C-5                |
| K557-1 Rear Handle Kit .....                                     | C-5                |
| <b>MAINTENANCE .....</b>   | <b>SECTION D</b>   |
| Safety Precautions .....   | D-1                |
| Routine Maintenance .....  | D-1                |
| Circuit Protection and Automatic Shutdown .....                  | D-1                |
| Adjusting Speed Sensor Module .....                              | D-1                |
| Calibration of the LN-25 Wire Speed Dial .....                   | D-2                |
| <b>TROUBLESHOOTING GUIDE .....</b>                               | <b>SECTION E</b>   |
| How to Use the Troubleshooting Guide .....                       | E-1                |
| Troubleshooting Guide .....                                      | E-2                |
| <b>WIRING DIAGRAM .....</b>                                      | <b>SECTION F</b>   |
| <b>PHYSICAL DIMENSIONS .....</b>                                 | <b>SECTION F</b>   |
| <b>PARTS MANUAL .....</b>  | <b>P333 SERIES</b> |

---

## TECHNICAL SPECIFICATIONS – LN-25

| VOLTAGE  |  |   |                       |
|--|--|---|-----------------------|
| Constant Voltage (CV)<br>or<br>Constant Current (CC) |  | 15-40 VDC (110VDC Maximum OCV)                  |                       |
| RATED CURRENT  |  |   |                       |
| Rated current without contactor                      |  | 500 Amps 60% Duty Cycle                         |                       |
| Rated current with contactor                         |  | 300 Amps 60% Duty Cycle                         |                       |
| WIRE FEED SPEED                                      |  |   |                       |
| 50 – 700 Inches Per Minute (IPM)                     |  |   |                       |
| WIRE DIAMETERS                                       |  |   |                       |
| .023" to 1/16"<br>.045" to 5/64"<br>.035" to 1/16"   |  | SOLID STEEL WIRE<br>CORED WIRE<br>ALUMINUM WIRE |                       |
| PHYSICAL DIMENSIONS                                  |  |   |                       |
| HEIGHT<br>(Handle Down)                              | WIDTH                                  | DEPTH   | WEIGHT<br>w/o Options |
| 14 Inches<br>(354 mm)                                | 7.4 Inches<br>(187 mm)                 | 21 Inches<br>(531 mm)                           | 28 lbs<br>(13 kg)     |
| TEMPERATURE RANGE                                    |  |   |                       |
| OPERATION:   | - 40° C to +40° C (- 40° F to +104° F) |   |                       |
| STORAGE:   | - 40° C to +85° C (- 40° F to +185° F) |   |                       |
| ENVIRONMENTAL RATING                                 |  |   |                       |
| IP23   |  |   |                       |

LN-25





## SAFETY PRECAUTIONS

### ⚠ WARNING

Unless an optional output control or contactor is used with the LN-25, the electrode circuit (including welding wire, wire drive and welding gun) is electrically hot when the welding power source is on. The gun trigger controls wire feed only.

Disconnect or shut off welding power source before making connections or installations to the LN-25.

Welding gun should be stored in the insulated gun holder, located near the rear on the top of the LN-25 case, to avoid accidental arcing.

The LN-25 should be positioned upright on a horizontal surface.

### ⚠ WARNING



ELECTRIC SHOCK can kill.

- Do not touch metal portions of the LN-25 lead clip when welding power source is on.

## POWER SOURCE CONNECTION

The LN-25 can be used with most DC welding power source. A constant voltage power source is recommended; however, the LN-25 can also be used with a constant current power source as long as the open circuit voltage is less than 110V DC.

### ⚠ CAUTION

Do not use LN-25 models below Code 9200 with any TIG or Square Wave welding power sources. Do not use LN-25 models equipped with internal contactors with non- Lincoln TIG or Square Wave welding power sources. Damage to the LN-25 circuit can occur as a result of the high output inductance typically associated with these power sources. TIG high frequency power should never be applied to the LN-25.

If not using an LN-25 Remote Output Control option (See Remote Output Control Options and Cable Assemblies Section), the power source output must be electrically “hot” at all times when the power source is turned on.

See the power source instruction manual for proper power source connections and setting required.

### ⚠ WARNING



ELECTRIC SHOCK can kill.

- Do not operate with covers removed.
- Turn off power source before installing or servicing.
- Do not touch electrically hot parts.
- Turn the input power to the welding power source off at the fuse box before working in the terminal strip.
- Only qualified personnel should install, use or service this equipment.

## DC-250

- Connect a jumper from 2 to 4 on the power source terminal strip so the output will be energized when the DC-250 is turned on.
- Connect electrode cable to the “Innershield/GMAW” output terminal of polarity required by electrode. Connect work lead to other “Innershield/GMAW” output terminal.
- Place “Set to CV Electrode Cable Polarity” switch at appropriate position.
- Place power source toggle switch in “Output Control at DC-250” position, unless a Remote Control is connected to 75, 76 and 77 on the DC-250 terminal strip.
- Place mode switch in “Innershield GMAW (CV)” position. Set CV arc control to “2” (or “NORMAL” on some machines). Initially set the output control on “7”.

## DC-400 AND CV-400

- Connect a jumper from 2 to 4 on the power source terminal strip so the output will be energized when the power source is turned on.

**NOTE:** DC-400 machines above Code 9200 have an output toggle switch to perform this function.

- Connect the electrode cable to the output terminal of polarity required by electrode. Connect work lead to other output terminal.

LN-25

- c. Place “Set to Same Polarity As Electrode Cable Connection” switch at appropriate position.
- d. Place power source toggle switch in “Output Control at DC(CV) -400” position, unless a remote control is connected to 75, 76 and 77 on the power source terminal strip.
- e. If power source has a mode switch, set switch to Constant Voltage Innershield. Initially set the output control on “6”.

### DC-600

- a. Connect a jumper from 2 to 4 on the power source terminal strip so the output will be energized when the DC-600 is turned on. (For DC-600 below Code 8200, also jumper N to S.)
- b. Connect the electrode cable to the output terminal of polarity required by electrode. Connect work lead to other output terminal.
- c. Place “Set to Same Polarity As Electrode Cable Connection” switch at appropriate position.
- d. Place power source toggle switch in “Output Control at DC-600” position, unless a remote control is connected to 75, 76 and 77 on the DC-600 terminal strip.
- e. Set mode switch to Constant Voltage Innershield. Initially set output control on “4”.

### R3S-325

- a. Connect a jumper from 4 to 32 on the power source terminal strip so that the output will be energized when the R3S-325 is turned on.
- b. Connect the electrode cable to the output terminal of polarity required by electrode. Connect work lead to other output terminal.
- c. Set power source per its instruction manual.

**NOTE:** Use of the optional Line Voltage Compensator available for the R3S-325 is recommended if input line voltage variation exceeds  $\pm 3\%$ .

### SAM-400, —650

- a. Connect a jumper from 2 to C4 on the power source terminal strip so the output will be energized when the SAM power source is on.
- b. Connect work lead to WORK stud. Connect electrode to AUTO EQUIPMENT stud. Connect SAM-650 “Tap” lead to the Innershield stud desired.

- c. Set ELECTRODE POLARITY switch to constant voltage polarity required by electrode.
- d. Set toggle switch to “Constant Voltage” and set the Constant Voltage Control on welder and the portable field control on #5 for initial start.

### SA-200, —250 OR SAE-300, —400 (WITH CV ADAPTER)

- a. For electrode negative welding, connect the electrode lead from the LN-25 to the output terminal on the CV Adapter, and the work lead to the power source output terminal labeled “POSITIVE”. For electrode positive welding, interchange the above lead connections so the LN-25 electrode lead is then connected to the positive power source terminal.
- b. Place both switches on the CV Adapter to the CV INNERSHIELD position and make appropriate power source settings per the CV Adapter instructions provided for the power source being used.
- c. The output voltage is set with the voltage control on the CV Adapter.

**NOTE:** Refer to the Instruction Manual provided with the machine for details on connection and operation of the LN-25 with the power source.

### INVERTEC, CV300 AND OTHER NEWER LINCOLN POWER SOURCES

Refer to the instruction manual provided with the power source for details on connection and operation of the LN-25 with these newer machines.

## GUN CABLE CONNECTION TO FEEDER

Lay the cable out straight. Insert the connector on the welding conductor cable into the brass conductor block on the front of the wire drive unit. Make sure it is all the way in and tighten the hand wheel clamp. Keep this connection clean and bright. Connect the control cable polarized amphenol plug into the mating 5-cavity receptacle on the front panel of the wire feeder case.

### FOR GMA GUN AND CABLES:

Requires installation of K430-1 Gas Solenoid Kit (factory installed on K446 and K449 models).

See K430-1 Gas Solenoid Kit Section (in Accessories Section) for gas solenoid operation and gas supply connection.

LN-25



Install the barbed fitting and union nut to the 5/8-18 female inert gas fitting on the front panel of the LN-25 case. Connect the 3/8" I.D. gas hose from the gun cable to the barbed fitting.

When the gun is to be removed, this fitting can be easily detached by loosening the union nut.

## WELD CABLE CONNECTION

The size of the electrode cable and work cable must be sufficient for the maximum weld current and total cable length to be used. Refer to table A.1.

TABLE A.1

| Weld Current<br>60% Duty Cycle | Total Cable Length |           |           |           |
|--------------------------------|--------------------|-----------|-----------|-----------|
|                                | 50'-100'           | 100'-150' | 150'-200' | 200'-250' |
| 200Amps                        | 2 AWG              | 2 AWG     | 1 AWG     | 1/0       |
| 300Amps                        | 1 AWG              | 1 AWG     | 1/0       | 2/0       |
| 400Amps                        | 2/0                | 2/0       | 3/0       | 3/0       |
| 500Amps                        | 2/0                | 3/0       | 3/0       | 4/0       |

## ELECTRODE CABLE CONNECTION

Route the electrode cable through the oval hole in the lower portion of the LN-25 rear panel. Connect the electrode cable to the LN-25 input stud using the 1/2" nut provided.

Secure the cable with the strain relief clamp provided. All units are supplied with an optional pigtail for customers that prefer to make a taped and bolted connection externally.

## WORK CABLE CONNECTION

Connect a work lead of sufficient size between the proper output stud on the power source and the work. Be sure the connection to the work makes tight metal-to-metal electrical contact. Poor work lead connections can result in poor welding performance.

## WIRE FEED DRIVE ROLL AND GUIDE TUBE KITS

### ⚠ WARNING

Turn off power source before installing or changing drive roll and/or guide tubes.

**NOTE:** The maximum wire sizes the LN-25 will satisfactorily feed are 5/64" cored and 1/16" solid electrodes.

The electrode sizes that can be fed with each roll and guide tube are stencilled<sup>(1)</sup> on each part. Check the kit for proper components. See the instructions, included with the drive roll kit, to install these parts on new machines or replace them on used machines. Refer to table A.2.

TABLE A.2

|  | Kit  | Instructions |
|--|--|--------------|
| <b>Steel Wire Sizes:</b><br>.068-3/64 Cored<br>1/16 (.062) Cored or Solid Steel<br>(Can also be used for .052)<br>.045 and .052 Solid Steel<br>.045 and .052 Cored<br>.035 Solid Steel<br>.035 Cored<br>.030 Solid Steel<br>.025 Solid Steel | KP653-3/32<br>-1/16<br>-.052<br>-.052C<br>-.035S<br>-.035C<br>-.030S<br>-.025S | L9932        |
| <b>Aluminum Wire Sizes:</b><br>1/16<br>3/64<br>.035  | KP654-1/16A<br>-3/64A<br>-.035A  | L9932        |

<sup>(1)</sup>Drive rolls for only **cored** electrode sizes are stencilled with a "C" suffix to the wire sizes.

Drive rolls for only **solid** electrode sizes are stencilled with an "S" suffix to the wire sizes.

Drive rolls for aluminum wire sizes are stencilled with an "A" suffix to the wire sizes.

LN-25

**LINCOLN**<sup>®</sup>  
ELECTRIC

## SAFETY PRECAUTIONS

READ AND UNDERSTAND ENTIRE SECTION  
BEFORE OPERATING MACHINE

### WARNING



ELECTRIC SHOCK can kill.

- Do not touch electrically live part or electrode with skin or wet clothing.
- Insulate yourself from work and ground.
- Always wear dry insulating gloves.



FUMES AND GASSES can be dangerous.

- Keep your head out of fumes.
- Use ventilation or exhaust to remove fumes from breathing zone.

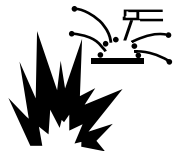

WELDING SPARKS can cause fire or explosion.

- Keep flammable material away.



ARC RAYS can burn.

- Wear eye, ear and body protection.

## GENERAL DESCRIPTION

The LN-25 is a lightweight portable semiautomatic wire feeder designed for “across-the-arc” operation without a control cable on most any DC welding power source. Simply connect the LN-25 to the electrode cable, clip it to Work and it is ready to weld, using up to 30 lb. coils or spools.

The wire drive, controls and wire reel are fully enclosed in a rugged molded plastic case providing a compact and versatile welding package ideally suited to “on-the-go” field welding applications in virtually any environment.

## RECOMMENDED PROCESSES AND EQUIPMENT

When combined with the quality drive roll kits and accessories available for use with the LN-25, a versatile portable welding system can be provided to meet the specific needs of Innershield, submerged arc or gas metal arc welding applications within the wire feed capabilities of the LN-25.

The LN-25 provides constant wire feed speed for use with constant voltage (CV) power sources, and arc-sensing wire feed speed for use with constant current (CC) (formerly variable voltage) power sources. Wire speed is presettable on a dual-range calibrated dial.

The power sources recommended for use with the LN-25 include the DC-250, -400, -600, CV-400 and R3S type transformer machines, and the SAM-400, -650 engine welders, as well as the SA-200, -250 or SAE-300, -400 with CV Adapter and Pulse Power 500 with K460-1 LN-25 Kit.

## WELDING CAPABILITY

The LN-25 will handle up to 500 Amp 60% duty cycle welding currents. However, when equipped with a K443-2 Contactor, the LN-25 will handle up to 300 Amp 60% duty cycle.

LN-25

**LINCOLN**<sup>®</sup>  
**ELECTRIC**

## LN-25 INSTRUMENTS AND CONTROLS

Refer to Figure B.1 for control locations.

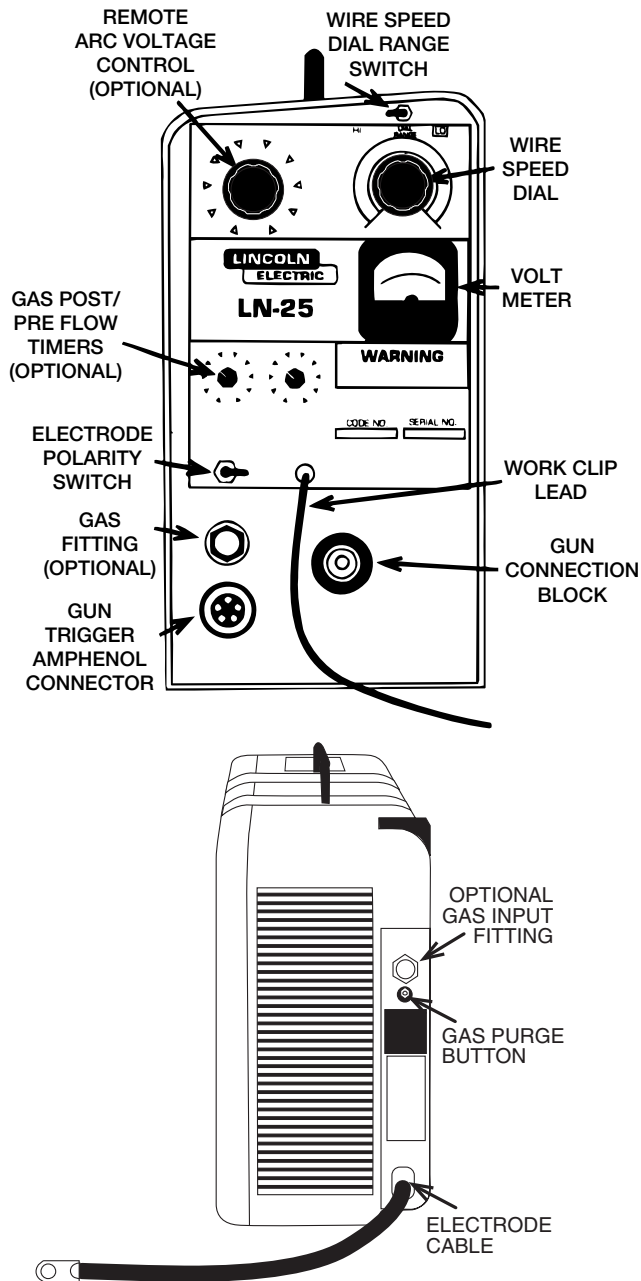

FIGURE B.1 CONTROL LOCATIONS

### VOLTMETER

(Factory installed on model Codes above 9218)

The 40V DC analog voltmeter is mounted to the front control panel of the LN-25 and is connected to read the arc voltage between the LN-25 electrode cable connection and the work clip lead.

### NOTE:

1. The Voltmeter will read zero if the LN-25 work clip lead is not connected to work, even if the electrode is electrically "hot" to work.
2. The Voltmeter will read below zero if the LN-25 polarity switch is not set to the same polarity as the electrode.
3. The Voltmeter will read power source open circuit voltage when the gun trigger is open, even if the LN-25 is equipped with the internal contactor.

### "ELECTRODE POLARITY" SWITCH

The polarity switch is located on the front panel of the LN-25 case.

Set the switch to the same polarity as the electrode lead connection to the power source. If the switch is not set for the correct polarity, the wire feeder will not operate.

### WIRE FEED MODE SWITCH

The CV-VV (CC) Wire Feed Mode switch is located inside the LN-25 case. The toggle switch extends from beneath the control box just above the wire drive.

The forward "CV" position provides constant wire feed speed mode for use with constant voltage (CV) welding power sources.

The backward "VV (CC)" position provides arc-sensing wire feed speed mode for use with constant current (formerly variable voltage) welding power sources.

### WIRE SPEED DIAL AND RANGE SWITCH

The Wire Speed control dial on the front panel of the LN-25 has two calibrated dial ranges selected by the HI-LO Dial Range switch.

When switched to the LO range position, the constant wire feed speed (CV Wire Feed Mode) is set on the inside (white) or (red) dial range calibrated for 50 to 350 in/min.

When switched to the HI range position, the constant wire feed speed (CV Wire Feed Mode) is set on the outside (black) or (blue) dial range calibrated for 50 to 700 in/min.

LN-25

**LINCOLN**<sup>®</sup>  
**ELECTRIC**

The volts marks around the HI range calibrated dial indicate the minimum arc volts required to obtain the indicated HI range wire feed speeds. For example; if wire speed is set to 400 in/min., a welding procedure arc voltage of at least 17V would be required to obtain the 400 in/min. wire feed speed.

#### WORK CLIP LEAD

### ⚠ WARNING



ELECTRIC SHOCK can kill.

- Do not touch metal portions of the LN-25 lead clip when welding power source is on.

### ⚠ WARNING

**IMPORTANT SAFETY NOTE:** To avoid possible electrical shock, do **not** touch the metal portions of the LN-25 work lead clip if the power source output is on. The clip will be electrically “HOT” to work if the input electrode cable to the LN-25 is electrically “HOT” even if the gun trigger is off and even if an internal contactor is used. Care should be taken to only handle the LN-25 work clip by its non-metal insulated portions and/or the welding power source should be turned off before handling the work clip.

The 15 ft. (4.6m) work clip lead attached to the front panel of the LN-25 case must be connected directly to the work using the spring clip on the end of the lead.

If not connected, the LN-25 will not operate even if a K431-1 or K624-1 (42V) Remote Output Control option (refer to Accessories Section) is used. However, the electrode will still be electrically “HOT” when the clip lead is disconnected, if K431-1 or K624-1 (42V) Remote Output Control Option, or Internal Contactor (K443-2), is not used.

When used with a K460-1 Pulse Power Adapter Kit, the LN-25 does not need a clip lead.

**NOTE:** The clip lead also serves as a work sensing lead for the LN-25 Voltmeter (if installed). If the clip lead is extended by the user beyond the standard 15 ft. (4.6m) length, the voltmeter reading will be lower than the actual arc volts due to the LN-25 motor control current flowing through the resistance of the extended lead. To minimize this voltmeter error, the following minimum lead size is recommended for the maximum extended lengths shown:

| AWG | Maximum Length |
|-----|----------------|
| #14 | 25 Ft(7.6m)    |
| #12 | 50 Ft(15.2m)   |
| #10 | 100 Ft(30.5m)  |
| #6  | 200 Ft(61m)    |

#### REMOTE ARC VOLTAGE CONTROL (OPTIONAL)

This rheostat control allows you to control the power source output arc voltage level. Refer to K444, K444-1 and K444-2 Remote Voltage Kits in the Accessories section.

#### GAS FITTING (OPTIONAL)

Provides gas output connection to the welding gun for the GMAW process. Refer to K430-2 Gas Solenoid Kit in the Accessories Section.

#### GAS POST PRE-FLOW TIMERS (OPTIONAL)

Allows for variable adjustment of gas pre-flow & post-flow at the start and end of the weld. Refer to K434-1 Gas Flow Timer Kit in Accessories Section.

LN-25





## SEQUENCE OF OPERATION

### LOADING ELECTRODE

#### ⚠ WARNING



ELECTRIC SHOCK can kill.

- Unless an optional output control or internal contactor is used with the LN-25, the electrode circuit is electrically “Hot” when the power source is on.
- Turn off the power source while mounting electrode coils.

### MOUNTING 22 TO 30 LB READI-REEL® COILS

The LN-25 will require an optional K363-P REDI-REEL® Adapter which is required to load Lincoln 22 to 30 lb REDI-REEL coils.

- Make certain that the threaded locking collar is tight and securely locks the adapter on the spindle (see figure B.2).
- Rotate the spindle and adapter so the retaining spring is at the 12 o'clock position.
- Position the REDI-REEL so that it will rotate in a clockwise direction when feeding (wire is to be dereeled from **bottom** of the coil).
- Set one of the REDI-REEL inside cage wires on the slot in the retaining spring tab.
- Lower the REDI-REEL to depress the retaining spring and align the other inside cage wires with the grooves in the molded adapter.
- Slide cage all the way onto the adapter until the retaining spring “pops up” fully.

#### ⚠ WARNING

Check to be sure the retaining spring has fully returned to the locking position and has securely locked the REDI-REEL cage in place. Retaining spring must rest on the cage, not the welding electrode.

- To remove REDI-REEL from Adapter, depress retaining spring tab with thumb while pulling the REDI-REEL cage from the molded adapter with both hands. It is not necessary to remove adapter from spindle.

- Load wire into wire drive per Loading Wire Drive Section.

### MOUNTING 10 TO 30 LB SPOOLS

For 12” Diameter Spools:

- Remove the locking collar and the REDI-REEL adapter (if so equipped) on the 2” diameter spindle (adapter is not required).
- Place the spool on the spindle so the brake holding pin enters one of the holes in the back side of the spool. Be sure the wire comes off the spool in a clockwise direction when dereeled from the bottom of the coil.
- Replace and tighten the locking collar.
- See Loading Wire Drive section for loading instructions.

For 8” Diameter Spools (Requires optional K468 Spindle Adapter for 8” Spools):

- Remove the locking collar and the REDI-REEL adapter (if so equipped) on the 2” diameter spindle (adapter is not required).
- Slide S18221 Spindle Adapter onto the 2” spindle so the brake holding pin enters the adapter pin hole.
- Place the spool on the spindle so the adapter tab enters one of the holes in the back side of the spool. Be sure the wire comes off the spool in a clockwise direction when dereeled from the bottom of the coil.
- Replace and tighten the Locking Collar.
- Load wire into wire drive per Loading Wire Drive Section.

**MOUNTING 13 OR 14 LB INNERSHIELD COILS**  
(Requires Optional K435 Spindle Adapter for 14 lb Coils.)

- Remove the locking collar and the REDI-REEL adapter (if so equipped) on the 2” diameter spindle (adapter is not required).
- Mount K435 Spindle Adapter and Innershield coil per the Instructions (S18256) included with the K435.

LN-25



FIGURE B.2 READI-REEL INSTALLATION

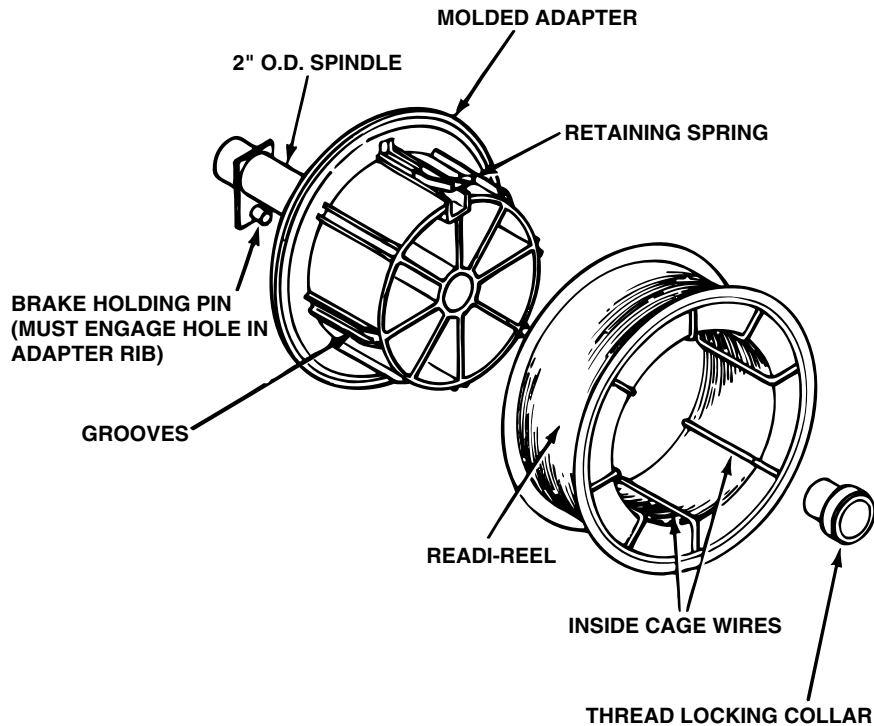

## LOADING WIRE DRIVE

- Turn the reel or spool until the free end of the electrode is accessible.
- While tightly holding the electrode, cut off the bent end and straighten the first six inches. Cut off the first inch. (If the electrode is not properly straightened, it may not feed or may not go into the outgoing guide tube causing a "bird nest".)
- Insert the free end through the incoming guide tube to the drive roll.
- Turn on the welding power source.

### ⚠ WARNING

Unless an optional output control or internal contactor is used with the LN-25, the electrode circuit is electrically "hot" when the power source is on.

- Press the gun trigger and push the electrode until it **just** enters the drive roll.

### ⚠ WARNING

When inching with gun trigger, the electrode and drive mechanism are always "hot" to work and ground. Use the "cold" inch switch on models with internal contactor.

- Inch the electrode through the gun.
- Adjust the brake tension with the thumbscrew on the spindle hub until the reel turns freely, but with little or no overrun when wire feeding is stopped. Do not over tighten.

### ⚠ CAUTION

Keep gun in LN-25 gun holder when not feeding wire to prevent accidental arcing.

## IDLE ROLL PRESSURE SETTING

The idle roll pressure is set at the factory backed out two turns from full pressure. This is an approximate setting. For small wire sizes and aluminum wire, the optimum idle roll pressure varies with type of wire, surface condition, lubrication and hardness. The optimum idle roll setting can be determined as follows:

- Press end of gun against a solid object that is electrically isolated from the welder output. Press the gun trigger for several seconds.
- If the wire "bird nests," jams or breaks at the drive roll, the idle roll pressure is too great. Back the pressure setting out  $\frac{1}{2}$  turn, run new wire through gun, and repeat above steps.

LN-25

3. If the only result is drive roll slippage, shut off the power source, then loosen the gun cable clamping screw in the gearbox conductor block and pull the gun cable forward about six inches. There should be a slight waviness in the exposed wire. If there is no waviness, the pressure is too low. Increase the pressure setting  $\frac{1}{4}$  turn, lock the gun cable in place and repeat the above steps.

### PRESETTING WIRE FEED SPEED

The LN-25 permits accurate presetting of the desired wire feed speed, in both CV and CC wire feed modes.

#### SETTING CONSTANT WIRE FEED SPEED (CV MODE)

- Set Wire Feed Mode switch to CV position.
- Set Dial Range switch to LO position for wire feed speeds up to 350 in/min., or HI position for wire feed speeds over 350 in/min.
- Set Wire Feed dial to the desired wire feed speed on the selected calibrated dial range.

The wire speed will remain constant at the value set, independent of arc voltage changes, as long as the arc voltage does not drop below the value per the chart below for the max. wire feed speed shown:

| Maximum Speed | Minimum Arc Volts |
|---------------|-------------------|
| 350 IPM       | 15V               |
| 400 IPM       | 17V               |
| 500 IPM       | 21V               |
| 600 IPM       | 24V               |
| 700 IPM       | 27V               |

#### SETTING ARC SENSING WIRE FEED SPEED (VV [CC] MODE)

When using a constant current (formerly variable voltage) power source, welding performance is improved using arc sensing wire feed speed (VV [CC] mode). In this wire feed mode the wire speed increases if arc voltage increases, and decreases if arc voltage decreases, but remains constant at any specific voltage level.

The LN-25 permits accurate VV (CC) mode presetting of the desired wire feed speed, for the desired arc voltage to be used, by setting the Wire Speed dial in the following manner before welding:

- Set Wire Feed Mode switch to VV (CC) position.

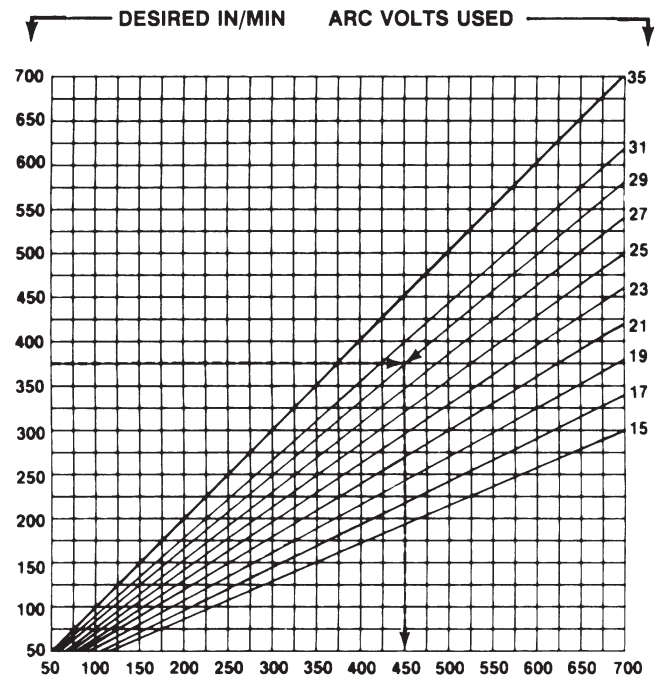

FIGURE B.3 CC WIRE SPEED SETTING

(HI or LO Range)

- Referring to the graph located above the Mode switch (also shown in Figure B.3):
  - Select the horizontal line representing the DESIRED IN/MIN. for the welding procedure. (See example arrow line for 375 in/min.)
  - Select the diagonal line representing the ARC VOLTS to be used for the welding procedure. (See example arrow line for 29 volts.)
  - Determine the vertical line representing the CC WIRE SPEED SETTING where the above two lines cross. (See example arrow line for 450.)
- Set the Wire Speed dial to the value determined in Step (3) above (450 for example used). Use HI Dial Range if value to be set is over 350.

The wire will feed at the DESIRED IN/MIN speed when the welding power source is set to the arc voltage to be used for the weld procedure (375 in/min. at 29V for example used).

A chart representation of the VV (CC) wire speed setting graph is shown in Figure B.4, giving the Wire Speed dial setting required for the DESIRED IN/MIN and ARC VOLTS used for the welding procedures:

LN-25

| Desired In/Min | Arc Volts Used |     |     |     |     |     |     |     |     |     |
|----------------|----------------|-----|-----|-----|-----|-----|-----|-----|-----|-----|
|                | 16             | 18  | 20  | 22  | 24  | 26  | 28  | 30  | 32  | 34  |
| 50             | 109            | 97  | 88  | 80  | 73  | 67  | 63  | 58  | 55  | 51  |
| 60             | 131            | 117 | 105 | 95  | 88  | 81  | 75  | 70  | 66  | 62  |
| 70             | 153            | 136 | 123 | 111 | 102 | 94  | 88  | 82  | 77  | 72  |
| 80             | 175            | 156 | 140 | 127 | 117 | 108 | 100 | 93  | 88  | 82  |
| 90             | 197            | 175 | 158 | 143 | 131 | 121 | 113 | 105 | 98  | 93  |
| 100            | 219            | 194 | 175 | 159 | 146 | 135 | 125 | 117 | 109 | 103 |
| 110            | 241            | 214 | 193 | 175 | 160 | 148 | 138 | 128 | 120 | 113 |
| 120            | 263            | 233 | 210 | 191 | 175 | 162 | 150 | 140 | 131 | 124 |
| 130            | 284            | 253 | 228 | 207 | 190 | 175 | 163 | 152 | 142 | 134 |
| 140            | 306            | 272 | 245 | 223 | 204 | 188 | 175 | 163 | 153 | 144 |
| 150            | 328            | 292 | 263 | 239 | 219 | 202 | 188 | 175 | 164 | 154 |
| 160            | 350            | 311 | 280 | 255 | 233 | 215 | 200 | 187 | 175 | 165 |
| 170            | 372            | 331 | 298 | 270 | 248 | 229 | 213 | 198 | 186 | 175 |
| 180            | 394            | 350 | 315 | 286 | 263 | 242 | 225 | 210 | 197 | 185 |
| 190            | 416            | 369 | 333 | 302 | 277 | 256 | 238 | 222 | 208 | 196 |
| 200            | 438            | 389 | 350 | 318 | 292 | 269 | 250 | 233 | 219 | 206 |
| 210            | 459            | 408 | 368 | 334 | 306 | 283 | 263 | 245 | 230 | 216 |
| 220            | 481            | 428 | 385 | 350 | 321 | 296 | 275 | 257 | 241 | 226 |
| 230            | 503            | 447 | 403 | 366 | 335 | 310 | 288 | 268 | 252 | 237 |
| 240            | 525            | 467 | 420 | 382 | 350 | 323 | 300 | 280 | 263 | 247 |
| 250            | 547            | 486 | 438 | 398 | 365 | 337 | 313 | 292 | 273 | 257 |
| 260            | 569            | 506 | 455 | 414 | 379 | 350 | 325 | 303 | 284 | 268 |
| 270            | 591            | 525 | 473 | 430 | 394 | 365 | 338 | 315 | 295 | 278 |
| 280            | 613            | 544 | 490 | 445 | 408 | 377 | 350 | 327 | 306 | 288 |
| 290            | 634            | 564 | 508 | 461 | 423 | 390 | 363 | 338 | 317 | 299 |
| 300            | 656            | 583 | 525 | 477 | 438 | 404 | 375 | 350 | 328 | 309 |
| 310            | 678            | 603 | 543 | 493 | 452 | 417 | 388 | 362 | 339 | 319 |
| 320            | 700            | 622 | 560 | 509 | 467 | 431 | 400 | 373 | 350 | 329 |
| 330            |                | 642 | 578 | 525 | 481 | 444 | 413 | 385 | 361 | 340 |
| 340            |                | 661 | 595 | 541 | 496 | 458 | 425 | 397 | 372 | 350 |
| 350            |                | 681 | 613 | 557 | 510 | 471 | 438 | 408 | 383 | 360 |
| 360            |                | 700 | 630 | 572 | 526 | 484 | 450 | 420 | 394 | 370 |
| 380            |                |     | 666 | 604 | 554 | 512 | 472 | 444 | 416 | 392 |
| 400            |                |     | 700 | 636 | 584 | 538 | 500 | 466 | 438 | 412 |
| 420            |                |     |     | 668 | 612 | 566 | 526 | 490 | 460 | 432 |
| 440            |                |     |     | 700 | 642 | 592 | 550 | 514 | 482 | 452 |
| 460            |                |     |     |     | 670 | 620 | 576 | 536 | 504 | 472 |
| 480            |                |     |     |     | 700 | 646 | 600 | 560 | 526 | 494 |
| 500            |                |     |     |     |     | 674 | 626 | 584 | 546 | 514 |
| 520            |                |     |     |     |     | 700 | 650 | 606 | 568 | 536 |
| 540            |                |     |     |     |     |     | 676 | 630 | 590 | 556 |
| 560            |                |     |     |     |     |     | 700 | 654 | 612 | 576 |
| 580            |                |     |     |     |     |     |     | 676 | 634 | 598 |
| 600            |                |     |     |     |     |     |     | 700 | 656 | 618 |
| 620            |                |     |     |     |     |     |     |     | 678 | 638 |
| 640            |                |     |     |     |     |     |     |     | 700 | 658 |
| 660            |                |     |     |     |     |     |     |     |     | 680 |
| 680            |                |     |     |     |     |     |     |     |     | 700 |
| 700            |                |     |     |     |     |     |     |     |     | 700 |

$$VV (CC) \text{ Speed Setting} = \frac{\text{Desired IPM}}{(\text{Arc Volts})} \times 35$$

FIGURE B.4 VV(CC) WIRE SPEED SETTING

### MAKING A WELD

The serviceability of a product or structure utilizing the LN-25 wire feeder is and must be the sole responsibility of the builder/user. Many variables beyond the control of The Lincoln Electric Company affect the results obtained in using the LN-25 wire feeder. These variables include, but are not limited to, welding procedure, plate chemistry and temperature, weldment design, fabrication methods and service requirements. The available range of the LN-25 wire feeder may not be suitable for all applications, and the builder/user is and must be solely responsible for welding settings.

#### SETUP

- a. Connect work cable to metal to be welded. Work cable must make good electrical contact to the work. The work must also be grounded as stated in "Arc Welding Safety Precautions."
- b. Check that the LN-25 is properly connected to the power source for the polarity and process to be used, and appropriate power source settings are made for the procedure to be used. (Refer to power source operating and connection instructions.)

**NOTE:** If the K431-1 Remote Output Control Kit or K624-1 42V Remote Control Module is installed but the LN-25 is to be used **without** the K432 Remote Control Cable Assembly, then the Remote Board harness plug must be removed from the 16-pin receptacle on the Control Board and the jumper plug (T13498-21) reinstalled.

**NOTE:** If the K460-1 Pulse Power Adapter Kit is installed but the LN-25 is to be used without the K461 Pulse Power Control Cable Assembly, then the instructions for returning the unit to across the arc operation included with the Installation Instructions (L9636) must be followed.

- c. Place the LN-25 conveniently near the work area in a location to minimize exposure to weld spatter and to avoid sharp bends in the gun cable.
- d. Connect the LN-25 Clip Lead to work and set Polarity Switch to same polarity as electrode.
- e. Set WIRE FEED MODE switch to CV or CC, as appropriate for the power source, then set the proper DIAL RANGE and WIRE SPEED dial setting for the proper wire feed speed per the welding procedure:

LN-25



**For CV:** Set dial to the calibrated IN/MIN desired. (Refer to Setting Constant Wire Feed Speed Section.)

**For CC:** Set dial to value determined from the CC Wire Speed Graph for the DESIRED IN/MIN and ARC VOLTS to be used. (Refer to Setting Arc Sensing Wire Feed Speed Section.)

**NOTE:** If procedure permits a range of acceptable arc voltage, use the middle of the range to determine proper WIRE SPEED setting.

- f. If using the optional Gas Flow Timer, set the desired PREFLOW TIME and POSTFLOW TIME.
- g. Be sure the proper contact tip for the wire size being used is in the gun, and the gun is safe from work contact. (Use the LN-25 insulated gun holder.)
- h. Turn on the welding power source, as well as the shielding gas supply (if used).

### ⚠ WARNING

Unless an optional output control or internal contactor is used, the electrode is electrically "hot" when the power source is on. The gun trigger controls wire feed and gas supplied to the nozzle area (if used).

### ⚠ WARNING

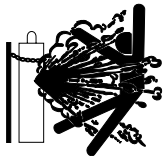

CYLINDER may explode if damaged.

- Keep cylinder upright and chained to support.
- Keep cylinder away from areas where it may be damaged.
- Never lift welder with cylinder attached
- Never allow welding electrode to touch cylinder.
- Keep cylinder away from welding or other live electrical circuits.

## WELDING

### ⚠ WARNING



ARC RAYS can burn.

- Do not touch metal portions of the LN-25 lead Clip when welding power source is on.

- a. Cut the electrode within approximately  $\frac{3}{8}$ " of the end of the contact tip for solid wire and within approximately  $\frac{1}{4}$ " of the extension guide for cored wire.
- b. Position electrode over joint. End of electrode should be slightly off the work.
- c. Lower welding helmet, close gun trigger, and begin welding. Hold the gun so the contact tip to work distance gives the correct electrical stickout as required for the procedure being used.

**NOTE:** If the arc voltage is not within the proper procedure range adjust the power source output control. (The CC mode WIRE SPEED setting should not be changed from the preset procedure value for the proper arc voltage.)

- d. To stop welding, release the gun trigger and then pull the gun away from the work. Store the gun in the LN-25 insulated gun holder when not welding.

## PROCEDURE AT END OF COIL

When the wire on the reel is used up, the following procedure is to be followed for removing the old wire from the gun cable and loading a new reel.

- a. Shut off power source if a Remote Output Control Option or internal contactor is not used.
- b. **Cut** the end of the electrode off at the gun end. Do not break it off by hand since this puts a slight bend in the wire and makes it difficult or impossible to pull it back through the nozzle.
- c. Uncouple the gun conductor cable from the LN-25.
- d. Lay the cable out straight.
- e. Using pliers to grip the wire, pull it out of the cable from the connector end. Do not pull it from the gun end.
- f. Put the conductor cable back on wire drive unit after the electrode has been removed.
- g. Load a new coil of wire and feed it through the cable as described in Loading Electrode Section.

## OPEN ARC WELDING WITH A CONSTANT CURRENT (formerly variable voltage) POWER SOURCE

### ⚠ WARNING

The LN-25 should be used with a constant current machine only upon non-critical weldments and after testing is done to assure quality is adequate for the application.

LN-25

## ⚠ CAUTION

Do not use LN-25 models below Code 9200 with any TIG or Square Wave welding power sources. Do not use LN-25 models equipped with internal contactors with non-Lincoln TIG or Square Wave welding power sources. Damage to the LN-25 circuit can occur as a result of the high output inductance typically associated with these power sources. TIG high frequency power should never be applied to the LN-25.

While welding with a continuously fed electrode, weld current variations are continuously taking place. There are many causes for these variations, but predominantly they occur due to changes in electrical stick out (operator hand movements, nozzle tip contact variations, etc.) and the dynamic metal transfer characteristics of the process or procedure being used (short arc, globular transfer, etc.).

When using a CV power source, these current variations have essentially no effect on the welding arc stability since CV power sources can provide a wide range of weld current levels with virtually no change in average arc voltage. These “flat slope” CV power sources, therefore, provide the arc power required to produce the best welding characteristics and ease of operation for most open arc, constant wire feed speed, welding processes.

CC (formerly VV) power sources, on the other hand, permit the arc voltage to decrease with increases in welding current. The output characteristics of these power sources can range from a “drooping slope,” which provide minor arc voltage changes with weld current variations, to “steep slope” which provide broad voltage changes with only minor current variations. The steeper the slope the more difficult it becomes to maintain arc voltage stability with a constant wire speed open arc process.

To aid in stabilizing the arc voltage when welding on CC power sources the LN-25 is provided with a VV (CC) wire feed mode. This arc voltage sensing feed mode decreases (or increases) the wire speed when the arc voltage decreases (or increases). **However**, if the electrode shorts to the work, the arc voltage will essentially drop to zero and the short circuit current supplied by the CC power source may not provide enough power to re-establish the arc (especially with steeper slope machines). Under this condition the LN-25 feeder will stop, as if the trigger was released, and not restart until the short has

been opened.

Arc shorting is more difficult to avoid when using a CC power source, and requires a more refined operator technique than when using a CV power source. Improved performance can be obtained on CC power source applications within the following guidelines:

1. Flatter slope power sources with higher arc force (short circuit current) will improve performance over steep slope machines. The steeper the slope, the more critical it is to hold proper electrode stick out to maintain arc stability. Welding techniques, such as weaving, will be more difficult to control. Use the highest output current tap or setting capable of providing the voltage adjustment required for the procedure.
2. Use spray or non-shorting small ball type transfer processes at higher procedure voltage levels. Generally, open arc processes with procedure voltage levels over 22 volts perform satisfactorily. Arc stability at procedure voltage levels below 22 volts may be more difficult to control, with the general exception of fine (.023— .035) solid steel electrodes with Argon-rich

## AUTOMATIC PROTECTION SHUTDOWN

The LN-25 control provides automatic electronic protection circuits which shut down the LN-25 for excessively high power source open circuit voltage or excessive motor overload.

### OVERVOLTAGE SHUTDOWN

If the power source open circuit voltage exceeds about 110-120 volts, the LN-25 will not operate until the power source voltage drops below about 102-110 volts.

### MOTOR OVERLOAD SHUTDOWN

If excessive motor overload occurs (due to prolonged excessive feeding force, jammed drive rolls or shorted motor leads), the LN-25 will shut down within a few seconds after the overload occurs.

The shutdown will reset automatically when the gun trigger is released, but will reoccur if the overload situation is not remedied.

LN-25



## How to use Table C.1.

Determine which Kit No. is to be used. Locate that Kit No. in the left hand vertical column. Scan horizontally to determine which LN-25 model is required and what additional kits may be required.

TABLE C.1

| LN-25 OPTION CHART   |   |              |            |            |            |      |      |        |      |        |        |        |      |        |      |      |      |
|--|---|--------------|------------|------------|------------|------|------|--------|------|--------|--------|--------|------|--------|------|------|------|
| O = CANNOT BE USED WITH X = REQUIRED ① = REQUIRES ONE OF THESE + = INCLUDED WITH |   |              |            |            |            |      |      |        |      |        |        |        |      |        |      |      |      |
| SEE TEXT   |   |              |            |            |            |      |      |        |      |        |        |        |      |        |      |      |      |
| KIT NO.  |   | LN-25 MODELS |            |            | LN-25 KITS |      |      |        |      |        |        |        |      |        |      |      |      |
|  |   | K428 LN-25   | K446 LN-25 | K449 LN-25 | K431-1     | K432 | K433 | K443-1 | K444 | K444-1 | K444-2 | K460-1 | K461 | K624-1 | K625 | K626 | K627 |
| K430-2   | Solenoid Kit                                | X            | +          | +          |            |      |      |        |      |        |        |        |      |        |      |      |      |
| K431-1   | Remote Output Control Module                | ①            | ①          | O          |            | X    | X    | O      | O    | O      | O      |        |      | O      |      |      |      |
| K432   | Remote Control Cable                        |              |            |            | X          |      | X    |        |      |        |        |        |      |        |      |      |      |
| K433   | 115VAC Power Source Remote Box              |              |            |            | X          | X    |      |        |      |        |        |        |      |        |      |      |      |
| K434-1   | Gas Flow Timer Kit                          |              |            | ①          | ①          |      |      | ①      |      |        |        | ①      |      | ①      |      |      |      |
| K439   | 50 Ft. Ext. Cable                           |              |            |            |            | X    |      |        |      |        |        |        |      |        |      |      |      |
| K443-2   | Contact Kit Codes 10500,10558               |              |            | +          | O          |      |      |        |      |        |        | O      |      | O      |      |      |      |
| K443-3   | Contact Kit Codes 11144 & Above             |              |            | +          | O          |      |      |        |      |        |        | O      |      | O      |      |      |      |
| K444   | Remote for Power Source w/Terminal Strip    | ①            | ①          | ①          | O          |      |      |        |      |        |        | O      |      | O      |      |      |      |
| K444-1   | Remote for Power Source w/6 Pin Amphenol    | ①            | ①          | ①          | O          |      |      |        |      |        |        | O      |      | O      |      |      |      |
| K444-2   | Remote for Power Source w/14 Pin Amphenol   | ①            | ①          | ①          | O          |      |      |        |      |        |        | O      |      | O      |      |      |      |
| K-624-1  | 42VAC Remote Output Control Module          | ①            | ①          | O          | O          |      |      | O      | O    | O      | O      | O      |      |        | ①    | ①    | ①    |
| K625   | 500 Amp Cable /w Stud-Type Output Terminals |              |            |            |            |      |      |        |      |        |        |        |      |        | X    |      |      |
| K626   | 350 Amp Cable /w Stud-Type Output Terminals |              |            |            |            |      |      |        |      |        |        |        |      |        | X    |      |      |
| K627   | 400 Amp Cable /w Twist-Mate Type Terminals  |              |            |            |            |      |      |        |      |        |        |        |      |        | X    |      |      |
| K460-1   | Pulse Power Adapter Kit                     | ①            | ①          | O          | O          |      |      | O      | O    | O      | O      |        | X    | O      |      |      |      |
| K461   | Pulse Power Control Cable                   |              |            |            |            |      |      |        |      |        |        | X      |      |        |      |      |      |

**IMPORTANT SAFETY NOTE:** This wire feeder provides "COLD" electrode when gun trigger is released if equipped with K431-1, K432 or K433 remote output control system, or K443-2 internal contactor kit. This feature and the use of a DC Constant Voltage welder provide an added margin of safety when welding must be performed under electrically hazardous conditions such as:

- Damp locations
- While wearing wet clothing
- On metal structures, or,
- In cramped positions (sitting, kneeling or lying) if there is a high risk of unavoidable or accidental contact with the workpiece or ground.

LN-25



## OPTIONAL ACCESSORIES

### ⚠ WARNING



ELECTRIC SHOCK can kill.

- Do not operate with covers removed.
- Turn off power source before installing or servicing.
- Do not touch electrically hot parts.
- Turn the input power to the welding power source off at the fuse box before working in the terminal strip.
- Only qualified personnel should install, use or service this equipment.

### ⚠ WARNING



CYLINDER may explode if damaged.

- Keep cylinder upright and chained to support.
- Keep cylinder away from areas where it may be damaged.
- Never lift welder with cylinder attached.
- Never allow welding electrode to touch cylinder.
- Keep cylinder away from welding or other live electrical circuits.
- See American National Standard Z-49.1, "Safety in Welding and Cutting" published by the American Welding Society.

### K430-2 GAS SOLENOID KIT

(For Codes above 10500 only)

(Factory Installed on K446 and K449 Models)

The kit permits the LN-25 to be used for Gas Metal Arc Welding (GMAW) processes with a GMA gun cable.

The kit can be used with or without a Remote Output Control option installed in the LN-25 and provides flow of shielding gas:

1. **With** wire feed, when the gun trigger is closed.
2. **Without** wire feed, when the kit's Purge button (located beneath the gas inlet fitting) is pressed.

**NOTE:** Always shut off the valve at the gas cylinder before making any gas connections to the LN-25.

User must provide a supply of shielding gas, a pressure regulator, a flow control valve and a hose from the flow valve to the gas inlet fitting of the LN-25. Install by connecting a supply hose from the gas flow valve outlet to the 5/8"-18 female inert gas fitting on the back panel of the LN-25 case.

The LN-25 can be used with any shielding gas recommended in the electrode's product literature at a maximum pressure of 60 psi (4.1 bar). This may include gases such as Argon, Helium, Nitrogen and blended gasses such as Ar-He, Ar-N<sub>2</sub>, Ar-O<sub>2</sub>, Ar-CO<sub>2</sub>, CO<sub>2</sub>, Ar-CO<sub>2</sub>-O<sub>2</sub>.

See GMA Gun Cable Gas Connection.

Installation instructions (M19154) are included with the kit.

### K434-1 GAS FLOW TIMER KIT

(Requires either a K431-1 Remote Output Control Kit, K460-1 Pulse Power Adapter Kit, K624-1 42V Remote Output Control Kit, or internal contactor K443-1 installed in LN-25).

The K434-1 Gas Flow Timer Kit is used with the LN-25 Gas Solenoid when the LN-25 is equipped with any of the Remote Output Control Options or internal contactor.

This kit provides the following gas flow timer functions:

1. **Preflow Control** - Provides flow of shielding gas to the work before the arc is established. The solenoid valve is energized immediately when the gun trigger is closed, but the time delay before the wire feeder and welding output are energized is adjustable between at least 0 to 1 second.
2. **Postflow Control** - Provides flow of shielding gas to the work after welding is stopped. Delay of the shut off of the solenoid valve after the gun trigger is released is adjustable between at least 0.5 to 5 seconds.

Installation instructions (M17590) are included with this kit.

LN-25





**K460-1 PULSE POWER ADAPTER KIT** (For use with K461 Pulse Power Control Cable.)(No Longer Available)

This kit enables the LN-25 to pulse weld with a Pulse Power 500 power source above Code 9300 (or lower Codes updated with Kit).

The kit includes a Remote PC board with output voltage control, and control cable receptacle which mount and connect inside the LN-25 control box per the Installation Instructions (L9636) included with the kit.

**NOTE:** If the K460-1 Pulse Power Adapter Kit is installed but the LN-25 is to be used without the K461 Pulse Power Control Cable Assembly, then the instructions for returning the unit to across the arc operation included with the Installation Instructions (L9636) must be followed.

**K461 PULSE POWER CONTROL CABLE ASSEMBLY** (No Longer Available)

(Requires K460-1 Pulse Power Adapter Kit installed in LN-25.)

The K461 control cable assemblies include an electrode cable, rated for up to 500 amps 60% duty cycle, and a 9-conductor control cable. The control cable pin connector connects to the LN-25 and the lugged leads connect to the Pulse Power. Available in 25, 50, 75 and 100 ft. lengths.

**K443-2 LN-25 CONTACTOR KIT**

**(For Codes 10500 - 10558 only)**

(Factory installed in K449 Model.)

The internal contactor provides “cold” electrode until the gun trigger is pressed, and a fixed burnback time delay to prevent electrode from sticking in the weld crater when the trigger is released. The contactor is rated for use up to 300 amps. A cold inch switch allows the wire to be loaded into the system without being electrically “hot”.

Installation Instructions (L10923) are included with the kit.

**NOTE:** The K443-2 cannot be used with K431-1 or K624-1 Remote Output Control Kit or K460-1 Pulse Power Adapter Kit. If remote voltage control is desired along with the internal contactor, obtain a K444, K444-1 or K444-2 Remote Voltage Control Kit.

## ⚠ CAUTION

This kit can only be used with LN-25's Code 10500-10558. To prevent possible damage to the LN-25 with internal contactor, do not connect to non-Lincoln TIG or Square Wave power sources. TIG high frequency power should never be applied to the LN-25.

**K443-3 LN-25 CONTACTOR KIT**

**(For Codes above 11100 only)**

(Factory installed in K449 Model.)

The internal contactor provides “cold” electrode until the gun trigger is pressed, and a fixed burnback time delay to prevent electrode from sticking in the weld crater when the trigger is released. The contactor is rated for use up to 300 amps. A cold inch switch allows the wire to be loaded into the system without being electrically “hot”.

Installation Instructions (L12319) are included with the kit.

**NOTE:** The K443-3 cannot be used with K431-1 or K624-1 Remote Output Control Kit or K460-1 Pulse Power Adapter Kit. If remote voltage control is desired along with the internal contactor, obtain a K444, K444-1 or K444-2 Remote Voltage Control Kit.

## ⚠ CAUTION

This kit can only be used with LN-25's above Code 11100. To prevent possible damage to the LN-25 with internal contactor, do not connect to non-Lincoln TIG or Square Wave power sources. TIG high frequency power should never be applied to the LN-25.

## REMOTE OUTPUT CONTROL OPTIONS AND CONTROL CABLE ASSEMBLIES

Remote Output Control Options are available to provide the LN-25 with the following additional features:

1. “Cold” electrode until the gun trigger is pressed, and a fixed burnback time delay to prevent electrode from sticking in the weld crater when the gun trigger is released.
2. Remote (10K ohm rheostat) control of power source output arc voltage level.

**K431-1 REMOTE OUTPUT CONTROL KIT**

(For use with K432 Remote Control Cable and K433 Power Source Remote Box.)

LN-25



The Kit includes a Remote PC board and control cable receptacle which mount and connect inside the LN-25 control box per the Installation Instructions (M17584) included with the kit.

**NOTE:** If the K431-1 Remote Output Control Kit is installed but the LN-25 is to be used without the K432 Remote Control Cable Assembly, then the Remote Board harness plug must be removed from the 16-pin receptacle on the Control Board and the jumper plug (T13498-21) reinstalled.

### **K433 POWER SOURCE REMOTE BOX**

(Requires K431-1 Remote Output Control Kit installed in LN-25 using K432 Remote Control Cable.)

The Remote Box is designed to mount and connect to Lincoln Idealarc® semiautomatic power sources per the Installation Instructions (M15324) and power source connection diagrams included with the kit.

The Remote Box provides the proper welding power source control interface and isolated 24V AC input supply for the LN-25 equipped with the K431-1 Remote Output Control Kit.

Remote Box requires 115V AC, 50/60 Hz input and a welding power source using a contact closure output pilot circuit, as available on appropriate Lincoln welding power sources.

### **K432 REMOTE CONTROL CABLE ASSEMBLY**

(Requires K431-1 Remote Output Control Kit installed in LN-25 and K433 Remote Box mounted to power source with 115V AC auxiliary power.)

The K432 control cable assemblies include an electrode cable, rated for up to 500 amps 60% duty cycle, and a 6-conductor control cable with pin connectors on both ends. Available in 25, 50, 75 and 100 ft. lengths.

The cable assembly end with the socket pin connector connects to the LN-25 per the Instructions (M17584) included with the K431-1 kit.

The cable assembly end with the male pin connector connects to the K433 and power source per the Instructions included with the K433 kit.

### **K439 REMOTE EXTENSION CABLE ASSEMBLY**

The 50 ft. Extension cable assemblies are used to extend the K432 Remote Control Cable Assembly when longer cable lengths are required.

Multiple K439 Extensions may be used, however, to prevent excessive weld cable voltage drops, the 500 amp max. rating of the K432 should be reduced by at least 50 amps for each K439 Extension used. For example, if three K439 Extensions are used (150 ft total extension), the maximum welding current used should be less than 350 amps.

The K439 Extension cable end with the male pin connector connects to the K433 Remote Box and power source per the Instructions included with the K433 kit.

The K439 Extension cable end with the socket pin connector connects to the mating K432 cable end (or next K439 Extension cable end). The electrode cables are connected using the bolt and nut provided with the K439 Extension. Properly insulate the bolted connection with electrical tape.

### **K624-1 42V REMOTE OUTPUT CONTROL MODULE**

(For use with K625, K626, K627 Remote Control Cable)

The Module includes a 42V Remote PC board and control cable receptacle which mount and connect inside the LN-25 control box per the Installation Instructions (M17253) included with the kit.

**NOTE:** If the K624-1 42V Remote Output Control Module is installed but the LN-25 is to be used without the K625, K626 or K627 Remote Control Cable Assembly, then the Remote Board harness plug must be removed from the 16-pin receptacle on the Control Board and the jumper plug (T13498-21) reinstalled.

### **K625, K626, K627 REMOTE CONTROL CABLE ASSEMBLY**

(Requires K624-1 Remote Output Control Module installed in LN-25.)

The K625, K626, K627 control cable assemblies include an electrode cable and a 8-conductor control cable:

LN-25



The cable assembly end with the socket pin connector connects to the LN-25 per the Instructions (M17253) included with the K624-1 Kit.

| CABLE TYPE | 60% DUTY RATING | POWER SOURCE ELECTRODE CONNECTION |
|------------|-----------------|-----------------------------------|
| K625       | 500 Amps        | Stud Terminal                     |
| K626       | 350 Amps        | Stud Terminal                     |
| K627       | 400 Amps        | Twist-Mate™                       |

The cable assembly end with the male pin connector connects to the power source per the Instructions (M17253) included with the K624-1 kit.

#### **K444, K444-1 OR K444-2 REMOTE VOLTAGE CONTROL KIT**

(Not required if using K431-1 or K624-1 Remote Output Control Kit or K460-1 Pulse Power Adapter Kit.)

The Remote Voltage Control Kit provides remote (10K ohm rheostat) control of power source output arc voltage level.

**K444** connects to power sources with control terminal strip connections for lead numbers 75, 76 and 77.

**K444-1** connects to power sources with a 6-pin control receptacle.

**NOTE:** To use a K444-1 with power sources with only a 14-pin control receptacle, a K864 Adapter is required to connect to K444-1 and if using a power source without an output control switch, a K484 Jumper Plug will also be required to jumper the output pilot circuit (2-4).

**K444-2** connects to power sources with a 14-pin control receptacle and provides a 2-4 jumper to activate power source output.

Installation Instructions are included with the kit.

#### **K577-1 REAR HANDLE KIT**

(For LN-25 model codes above 9383)

The fold-down handle mounts to the rear of the LN-25 case per the Installation Instructions (M16567) shipped with the kit.

This handle provides a means to also carry the LN-25 in the vertical position, especially convenient for passing the unit through a manhole.

#### **K363P READI-REEL ADAPTER KIT**

Adapts Lincoln Redi-Reel coils of electrode 30 lb. (14 kg) and 22 lb. (10 kg) to a 2" (51mm) spindle. Durable molded plastic one piece construction. Designed for easy loading; adapter remains on spindle for quick changeover.

LN-25



The following Figures C.1 and C.2 should serve as a guide to determine if a particular gun or switch can be connected to the LN-25.

**GUN CABLE CONNECTOR REQUIREMENTS TO PERMIT PROPER CONNECTION TO LINCOLN LN-25 WIRE FEEDER.**

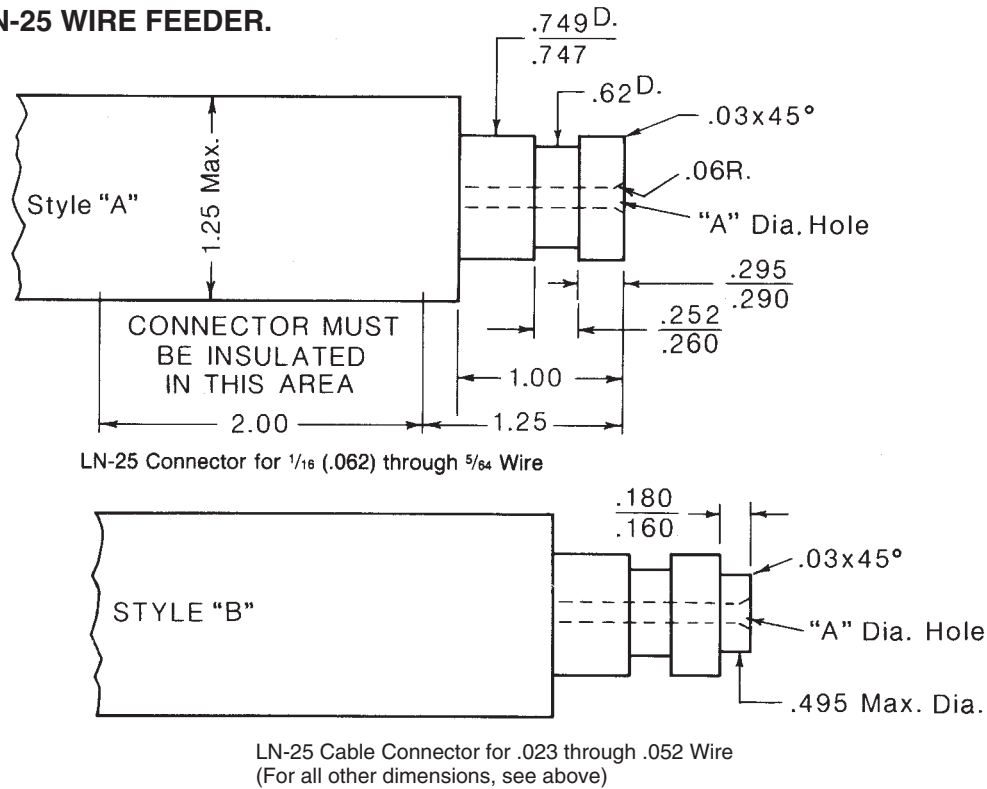

FIGURE C.1

**NOTE:** Connector part with .749/.747 diameter should be made from brass if it is to be part of the welding current carrying circuit.

| Wire Size      | "A Dia. Hole" To be Concentric to .749/.747 Dia. Within .008 F.I.M. |
|----------------|---|
| .068 thru 5/64 | .125 (1/8 Drill)  |
| 1/16 (.062)    | .078 (5/64 Drill)   |
| .045 & .052    | .062 (1/16 Drill)   |
| .023 thru .035 | .055 (#54 Drill)  |

| Drive Roll & Guide Tube Kit No. | Wire Sizes Used      |
|---------------------------------|----------------------|
| T-13355-3/8                     | 3/8, .072 & .068     |
| T-13355-1/8 <sup>(1)</sup>      | 1/8, .062            |
| T-13355-.052C                   | .045, .052 Cored     |
| T-13355-.052                    | .045, .052 Solid     |
| T-15010-.035S                   | .023 thru .035 Solid |

<sup>(1)</sup> Can also be used for .052" wire

**SWITCH REQUIREMENTS**

1/2 Amp AC 24 Volts – Inductive  
 1/2 Amp DC 24 Volts – Inductive

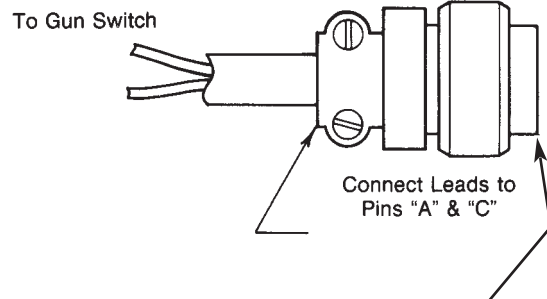

S12024-1 (L.E. Part No.)  
 Amphenol AN3057-10 (or equiv.)  
 S12020-6 (L.E. Part No.)  
 Amphenol MS-3106A-18-11P (or equiv.)

FIGURE C.2 SWITCH REQUIREMENTS

LN-25



## SAFETY PRECAUTIONS

### ⚠ WARNING



ELECTRIC SHOCK can kill.

- Do not operate with covers removed.
- Turn off power source before installing or servicing.
- Do not touch electrically hot parts.
- Turn the input power to the welding power source off at the fuse box before working in the terminal strip.
- Only qualified personnel should install, use or service this equipment.

## ROUTINE MAINTENANCE

### DRIVE ROLLS AND GUIDE TUBES

After feeding every coil of wire, inspect the drive roll section. Clean it as necessary. Do not use a solvent for cleaning the idle roll because it may wash the lubricant out of the bearing. The drive roll, idle roll and guide tubes are stamped with the wire sizes they will feed. If a wire size other than that stamped on the rolls is to be used, the rolls and guide tubes must be changed.

The drive rolls for .035 through .052 cored electrode and  $\frac{1}{16}$  through  $\frac{5}{64}$  electrode have a double set of teeth so they can be reversed for additional life. Drive rolls for .023 through .052 solid electrode and aluminum sizes have no teeth but use two grooves so they also can be reversed for additional life.

See Wire Feed Drive Roll and Guide Tube Kits Section for roll changing instructions.

### WIRE REEL SPINDLE

No routine maintenance required. Do not lubricate spindle.

## CONTROL BOX

Every six months open and inspect the control section. The accumulated dirt should be gently blown off all of the electrical components. Be sure the air that is being used is dry. Check that lead plugs are secure in their receptacles.

### WIRE DRIVE MOTOR AND GEAR BOX

Every year examine the gear box. Paint the gear teeth with molydisulfide filled grease. Lincoln specification E2322. **Do not** use a graphite grease.

Check the motor brushes. Replace if they are worn down to  $\frac{1}{4}$ " or less. When ordering feed motor brushes, give all information from the motor nameplate.

### GUN AND CABLE MAINTENANCE

See IM manual provided with the gun and cable assembly.

## CIRCUIT PROTECTION AND AUTOMATIC SHUTDOWN

### CONTROL PC BOARD

The Control P.C. Board has electronic protection for trigger circuit faults to the electrode circuit.

### AUTOMATIC PROTECTION SHUTDOWN

(See Automatic Protection Shutdown Section.)

## ADJUSTING SPEED SENSOR MODULE

The LN-25 Speed Sensor Module is a three lead Hall Effect switch device encased in an externally threaded housing which is screwed into a mounting plate on the motor side of the wire drive gearbox.

Proper positioning of this module is critical to proper operation of the LN-25 wire feed speed control. If the device is not screwed in far enough, the LN-25 motor speed could be unstable or run at full speed with no control. If screwed in too far, it will rub a moving part inside the gearbox.

The module is properly mounted to the gearbox as shipped from the factory. If the device is ever removed or replaced, proper mounting technique is as follows:

LN-25

1. Be sure all power to the LN-25 is shut off at the power source.
2. Check that the module mounting plate is screwed securely to the side of the gearbox.
3. Gently screw the module into the mounting plate until it **just** touches and stops against the rotating part inside the gearbox.
4. Back the module out  $\frac{1}{2}$  turn, then snug the module lock nut without rotating the module position. Do not over tighten lock nut.

## CALIBRATION OF LN-25 WIRE SPEED DIAL

Calibration of the LN-25 Wire Speed dial is achieved by proper mounting of the dial knob to the speed potentiometer shaft. Whenever the knob is removed, the dial is recalibrated as follows:

**NOTE:** Knob set screw does **not** seat on shaft flat.

1. Be sure the Wire Speed potentiometer mounting nut is securely tightened, then rotate the potentiometer shaft so its flat faces about to the 100 mark on the LO range calibrated dial.
2. Set DIAL RANGE switch to LO and WIRE FEED MODE switch to CV position.
3. Press gun trigger to feed wire and measure the wire feed speed (IN/MIN) using a Portable Digital Wire Feed Speed Meter (Lincoln K283). Take at least two readings to assure repeatable accuracy.

Feed Speed Meter (Lincoln K283). Take at least two readings to assure repeatable accuracy.

### WARNING

Electrode will be electrically "hot". Do not allow fed wire to contact any metal common with welding work.

An alternate means to measure wire feed speed is as follows:

- a. Cut wire off at the end of the gun tip.
  - b. Press trigger to feed wire for exactly 30 seconds.
  - c. Cut fed wire off at the end of the gun tip and accurately measure its length.
  - d. Multiply the measured length by 2 to obtain the wire speed (IN/MIN).
  - e. Repeat above steps to assure repeatable accuracy.
4. Carefully slip speed knob onto potentiometer shaft so it points precisely to the wire speed measured in step 3, then secure the knob set screw without disturbing the position. Recheck by repeating step 3.

LN-25

---

## HOW TO USE TROUBLESHOOTING GUIDE

### WARNING

Service and Repair should only be performed by Lincoln Electric Factory Trained Personnel. Unauthorized repairs performed on this equipment may result in danger to the technician and machine operator and will invalidate your factory warranty. For your safety and to avoid Electrical Shock, please observe all safety notes and precautions detailed throughout this manual.

This Troubleshooting Guide is provided to help you locate and repair possible machine malfunctions. Simply follow the three-step procedure listed below.

#### **Step 1. LOCATE PROBLEM (SYMPTOM).**

Look under the column labeled “PROBLEM (SYMPTOMS)”. This column describes possible symptoms that the machine may exhibit. Find the listing that best describes the symptom that the machine is exhibiting.

#### **Step 2. POSSIBLE CAUSE.**

The second column labeled “POSSIBLE CAUSE” lists the obvious external possibilities that may contribute to the machine symptom.

#### **Step 3. RECOMMENDED COURSE OF ACTION**

This column provides a course of action for the Possible Cause, generally it states to contact your local Lincoln Authorized Field Service Facility.

If you do not understand or are unable to perform the Recommended Course of Action safely, contact your local Lincoln Authorized Field Service Facility.

### CAUTION

If for any reason you do not understand the test procedures or are unable to perform the tests/repairs safely, contact your **Local Lincoln Authorized Field Service Facility** for technical troubleshooting assistance before you proceed.

---



| PROBLEMS<br>(SYMPTOMS)   | POSSIBLE<br>CAUSE   | RECOMMENDED<br>COURSE OF ACTION                                    |
|--|---|--|
| <b>FEEDING PROBLEMS</b>  |   |  |
| No wire feed when gun trigger is pulled  | <ol style="list-style-type: none"> <li>1. Power source must be on and open circuit voltage (OCV) present at weld terminals.</li> <li>2. LN-25 work clip may not be connected.</li> <li>3. LN-25 polarity switch must match electrode polarity.</li> <li>4. Jumper plug on control or option board may be loose or missing.</li> <li>5. The power source O.C.V. must be above 15 VDC. But not more than 110 VDC.</li> <li>6. The gun trigger may be faulty.- Replace gun.</li> </ol> | Contact your local<br>Lincoln Authorized<br>Field Service Facility |
| Wire feeds for a short time but stops feeding. When gun trigger is released and retriggered wire feeding starts but stops again. | <ol style="list-style-type: none"> <li>1. The drive motor may be overloaded. Check the wire feeding system. EX. Drive roll tension, reel brake and gun cable liner.</li> </ol>  |  |
| Wire feeds OK, but stubs or stops while welding.   | <ol style="list-style-type: none"> <li>1. If the power source is a constant current type supply the arc voltage may be "dipping" below 15 VDC causing the LN-25 to stop or hesitate.</li> <li>2. Connect a constant voltage type power supply to the LN-25.</li> <li>3. Make sure wire-feed mode switch (S3) is in the proper position.</li> </ol>  |  |

**⚠ CAUTION**

If for any reason you do not understand the test procedures or are unable to perform the tests/repairs safely, contact your local authorized field service facility for technical troubleshooting assistance before you proceed.

LN-25



| PROBLEMS<br>(SYMPTOMS)  | POSSIBLE<br>CAUSE  | RECOMMENDED<br>COURSE OF ACTION   |
|---|--|---|
| <b>FEEDING PROBLEMS</b>   |  |   |
| Rough wire feeding or wire not feeding but drive rolls turning. | <ol style="list-style-type: none"> <li>1. Gun cable kinked and/or twisted.</li> <li>2. Wire jammed in gun and cable.</li> <li>3. Incorrect size or installation of drive roll and guide tubes.</li> <li>4. Drive roll loose.</li> <li>5. Gun cable dirty.</li> <li>6. Worn drive roll.</li> <li>7. Electrode rusty and/or dirty.</li> <li>8. Worn nozzle or cable liner.</li> <li>9. Partially flashed or melted contact tip.</li> <li>10. Incorrect idle roll pressure.</li> <li>11. Wire reel brake tension set too high.</li> </ol> | <p>Contact your local<br/>Lincoln Authorized<br/>Field Service Facility</p> |

**⚠ CAUTION**

If for any reason you do not understand the test procedures or are unable to perform the tests/repairs safely, contact your local authorized field service facility for technical troubleshooting assistance before you proceed.

| PROBLEMS<br>(SYMPTOMS)  | POSSIBLE<br>CAUSE  | RECOMMENDED<br>COURSE OF ACTION   |
|---|--|---|
| <b>OUTPUT PROBLEMS</b>  |  |   |
| Solenoid does not close when trigger is pulled or purge button is pressed. Wire feeds properly. | <ol style="list-style-type: none"> <li>1. Make certain that plugs J2 and J3 are connected to the control board securely.</li> </ol>  |   |
| <b>WELD PROBLEMS</b>  |  |   |
| Variable or "hunting" arc.  | <ol style="list-style-type: none"> <li>1. Worn and/or melted contact tip -Replace.</li> <li>2. Worn work cable or poor work connection.</li> <li>3. Loose electrode connections. -Check for loose or faulty connections.</li> <li>4. Wrong electrode polarity for process being used.</li> </ol> | <p>Contact your local<br/>Lincoln Authorized<br/>Field Service Facility</p> |
| Weld porosity, narrow and ropey bead, or electrode stubbing into plate when welding.            | <ol style="list-style-type: none"> <li>1. Contaminated weld joint or improper procedures. - Clean joint and check procedure (wire speed and all voltage).</li> </ol>   |   |
| Motor feeds but there is no wire feed speed control.  | <ol style="list-style-type: none"> <li>1. Make sure all molex plugs and leads are securely connected to the control board.</li> <li>2. Check speed sensor - see maintenance section.</li> </ol>  |   |

**⚠ CAUTION**

If for any reason you do not understand the test procedures or are unable to perform the tests/repairs safely, contact your local authorized field service facility for technical troubleshooting assistance before you proceed.

## WIRING DIAGRAM LN-25 FOR CODES 10556, 10557 AND 10558

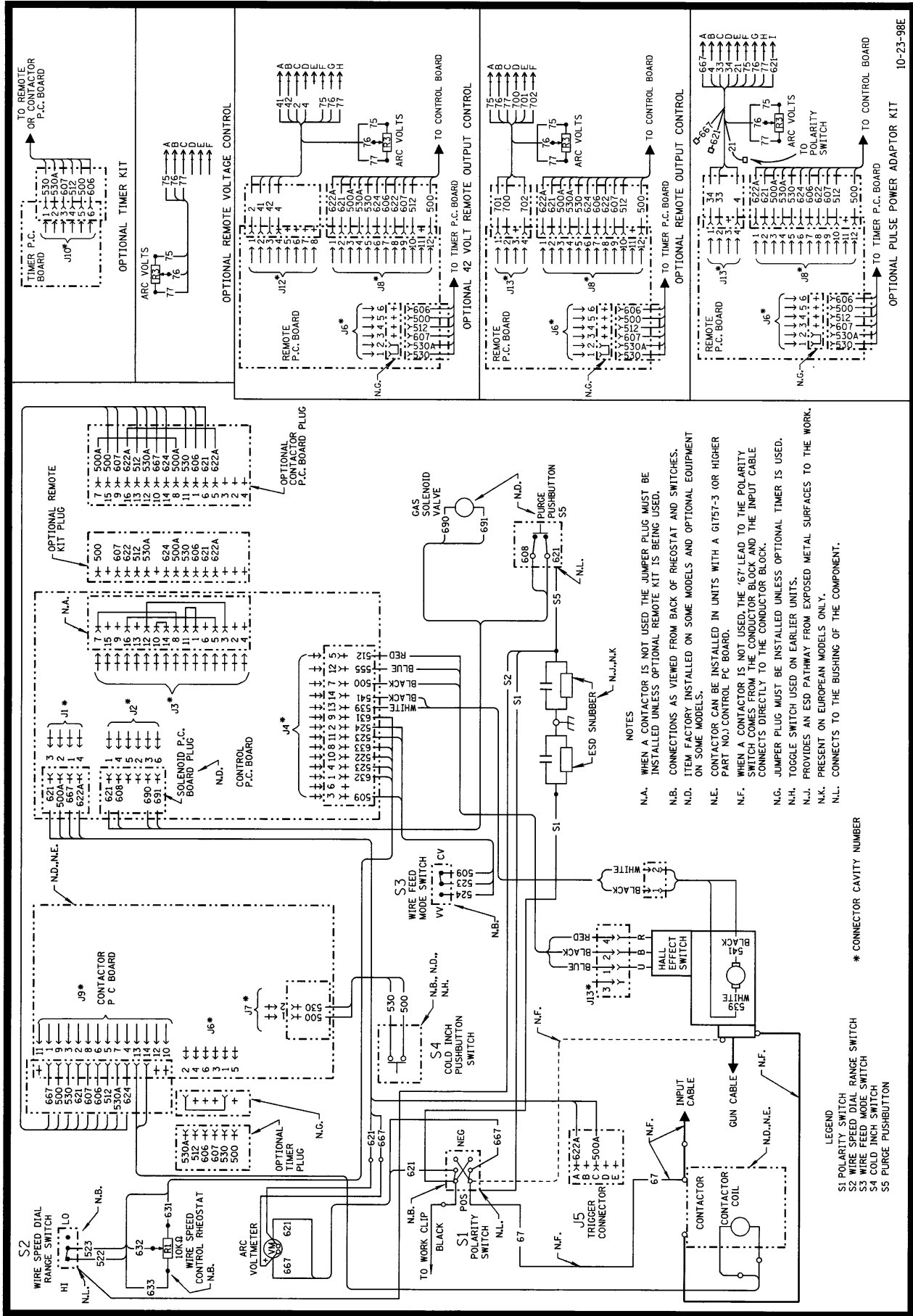

LN-25



NOTE: This diagram is for reference only. It may not be accurate for all machines covered by this manual. The specific diagram for a particular code is pasted inside the machine on one of the enclosure panels. If the diagram is illegible, write to the Service Department for a replacement. Give the equipment code number.

L10925

OPTIONAL PULSE POWER ADAPTOR KIT 10-23-98E

WIRING DIAGRAM - LN-25 FOR CODES 11144 AND 11145

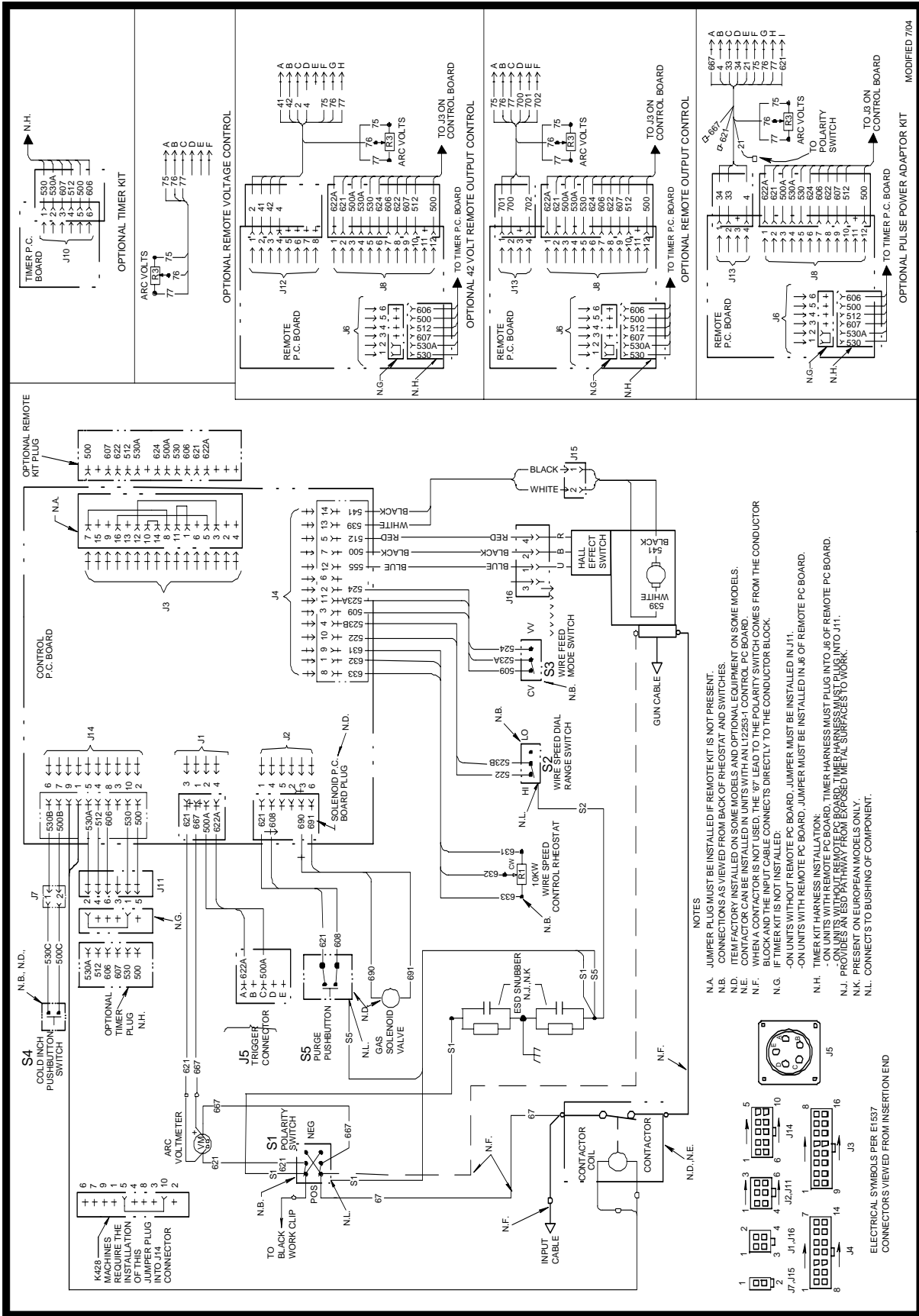

- NOTES**
- N.A. JUMPER PLUG MUST BE INSTALLED IF REMOTE KIT IS NOT PRESENT.
  - N.B. CONNECTIONS AS VIEWED FROM BACK OF RHEOSTAT AND SWITCHES.
  - N.D. TEMPORARY INSTALLED ON SOME MODELS AND OPTIONAL EQUIPMENT ON SOME MODELS.
  - N.F. WHEN A CONTACTOR IS NOT USED, THE 87 LEAD TO THE POLARITY SWITCH COMES FROM THE CONDUCTOR BLOCK AND THE INPUT CABLE CONNECTS DIRECTLY TO THE CONDUCTOR BLOCK.
  - N.G. IF TIMER KIT IS NOT INSTALLED:
    - ON UNITS WITHOUT REMOTE P.C. BOARD, JUMPER MUST BE INSTALLED IN J1.
    - ON UNITS WITH REMOTE P.C. BOARD, JUMPER MUST BE INSTALLED IN J6 OF REMOTE P.C. BOARD.  - N.H. TIMER KIT HARNESS INSTALLATION:
    - ON UNITS WITH REMOTE P.C. BOARD, TIMER HARNESS MUST PLUG INTO J6 OF REMOTE P.C. BOARD.
    - ON UNITS WITHOUT REMOTE P.C. BOARD, TIMER HARNESS MUST PLUG INTO J1.  - N.J. PROVIDES AN ESD PATHWAY FROM EXPOSED METAL SURFACES TO WORK.
  - N.K. PRESENT ON EUROPEAN MODELS ONLY.
  - N.L. CONNECT TO BUSHING OF COMPONENT.

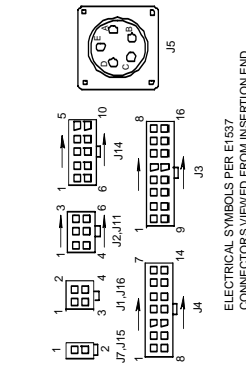

ELECTRICAL SYMBOLS PER E1537  
CONNECTORS VIEWED FROM INSERTION END

G4679

MODIFIED 7/04

NOTE: This diagram is for reference only. It may not be accurate for all machines covered by this manual. The specific diagram for a particular code is pasted inside the machine on one of the enclosure panels. If the diagram is illegible, write to the Service Department for a replacement. Give the equipment code number.

LN-25



LN-25 PHYSICAL DIMENSIONS

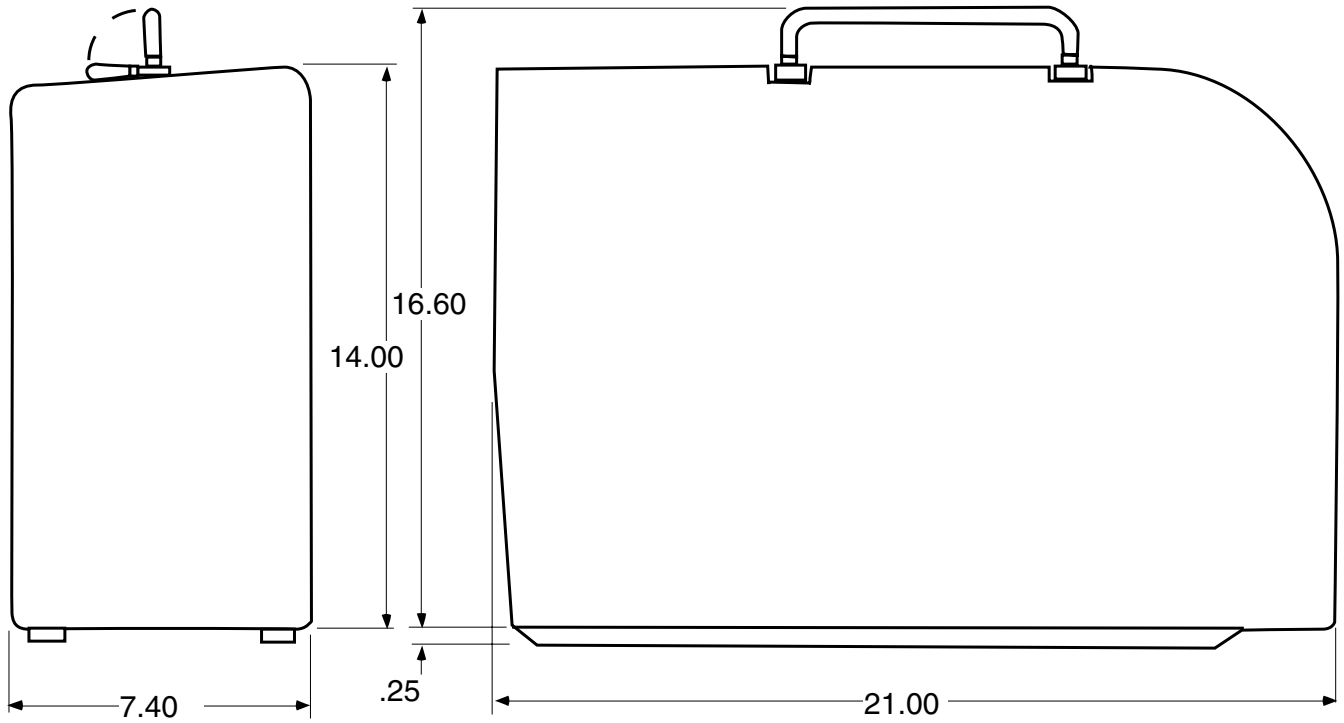

LN-25



# NOTES

---

LN-25





# NOTES

---

LN-25



|                                       |   |   |   |
|---------------------------------------|---|---|---|
|                                       |   |   |   |
| <b>WARNING</b>                        | <ul style="list-style-type: none"> <li>● Do not touch electrically live parts or electrode with skin or wet clothing.</li> <li>● Insulate yourself from work and ground.</li> </ul>                                     | <ul style="list-style-type: none"> <li>● Keep flammable materials away.</li> </ul>                              | <ul style="list-style-type: none"> <li>● Wear eye, ear and body protection.</li> </ul>              |
| Spanish<br><b>AVISO DE PRECAUCION</b> | <ul style="list-style-type: none"> <li>● No toque las partes o los electrodos bajo carga con la piel o ropa mojada.</li> <li>● Aíslese del trabajo y de la tierra.</li> </ul>   | <ul style="list-style-type: none"> <li>● Mantenga el material combustible fuera del área de trabajo.</li> </ul> | <ul style="list-style-type: none"> <li>● Protéjase los ojos, los oídos y el cuerpo.</li> </ul>      |
| French<br><b>ATTENTION</b>            | <ul style="list-style-type: none"> <li>● Ne laissez ni la peau ni des vêtements mouillés entrer en contact avec des pièces sous tension.</li> <li>● Isolez-vous du travail et de la terre.</li> </ul>                   | <ul style="list-style-type: none"> <li>● Gardez à l'écart de tout matériel inflammable.</li> </ul>              | <ul style="list-style-type: none"> <li>● Protégez vos yeux, vos oreilles et votre corps.</li> </ul> |
| German<br><b>WARNUNG</b>              | <ul style="list-style-type: none"> <li>● Berühren Sie keine stromführenden Teile oder Elektroden mit Ihrem Körper oder feuchter Kleidung!</li> <li>● Isolieren Sie sich von den Elektroden und dem Erdboden!</li> </ul> | <ul style="list-style-type: none"> <li>● Entfernen Sie brennbares Material!</li> </ul>                          | <ul style="list-style-type: none"> <li>● Tragen Sie Augen-, Ohren- und Körperschutz!</li> </ul>     |
| Portuguese<br><b>ATENÇÃO</b>          | <ul style="list-style-type: none"> <li>● Não toque partes elétricas e electrodos com a pele ou roupa molhada.</li> <li>● Isole-se da peça e terra.</li> </ul>   | <ul style="list-style-type: none"> <li>● Mantenha inflamáveis bem guardados.</li> </ul>                         | <ul style="list-style-type: none"> <li>● Use proteção para a vista, ouvido e corpo.</li> </ul>      |
| Japanese<br><b>注意事項</b>               | <ul style="list-style-type: none"> <li>● 通電中の電気部品、又は溶材にヒフやぬれた布で触れないこと。</li> <li>● 施工物やアースから身体が絶縁されている様にして下さい。</li> </ul>  | <ul style="list-style-type: none"> <li>● 燃えやすいものの側での溶接作業は絶対にしてはなりません。</li> </ul>                                | <ul style="list-style-type: none"> <li>● 目、耳及び身体に保護具をして下さい。</li> </ul>                              |
| Chinese<br><b>警告</b>                  | <ul style="list-style-type: none"> <li>● 皮肤或湿衣物切勿接触带电部件及焊条。</li> <li>● 使你自已与地面和工作件绝缘。</li> </ul>  | <ul style="list-style-type: none"> <li>● 把一切易燃物品移离工作场所。</li> </ul>  | <ul style="list-style-type: none"> <li>● 佩戴眼、耳及身体劳动保护用具。</li> </ul>                                 |
| Korean<br><b>위험</b>                   | <ul style="list-style-type: none"> <li>● 전도체나 용접봉을 젖은 헝겍 또는 피부로 절대 접촉치 마십시오.</li> <li>● 모재와 접지를 접촉치 마십시오.</li> </ul>  | <ul style="list-style-type: none"> <li>● 인화성 물질을 접근시키지 마십시오.</li> </ul>   | <ul style="list-style-type: none"> <li>● 눈, 귀와 몸에 보호장구를 착용하십시오.</li> </ul>                          |
| Arabic<br><b>تحذير</b>                | <ul style="list-style-type: none"> <li>● لا تلمس الاجزاء التي يسري فيها التيار الكهربائي أو الألكترود بجسد الجسم أو بالملابس المبللة بالماء.</li> <li>● ضع عازلا على جسمك خلال العمل.</li> </ul>                        | <ul style="list-style-type: none"> <li>● ضع المواد القابلة للاشتعال في مكان بعيد.</li> </ul>                    | <ul style="list-style-type: none"> <li>● ضع أدوات وملابس واقية على عينيك وأذنيك وجسمك.</li> </ul>   |

**READ AND UNDERSTAND THE MANUFACTURER'S INSTRUCTION FOR THIS EQUIPMENT AND THE CONSUMABLES TO BE USED AND FOLLOW YOUR EMPLOYER'S SAFETY PRACTICES.**

**SE RECOMIENDA LEER Y ENTENDER LAS INSTRUCCIONES DEL FABRICANTE PARA EL USO DE ESTE EQUIPO Y LOS CONSUMIBLES QUE VA A UTILIZAR, SIGA LAS MEDIDAS DE SEGURIDAD DE SU SUPERVISOR.**

**LISEZ ET COMPRENEZ LES INSTRUCTIONS DU FABRICANT EN CE QUI REGARDE CET EQUIPMENT ET LES PRODUITS A ETRE EMPLOYES ET SUIVEZ LES PROCEDURES DE SECURITE DE VOTRE EMPLOYEUR.**

**LESEN SIE UND BEFOLGEN SIE DIE BETRIEBSANLEITUNG DER ANLAGE UND DEN ELEKTRODENEINSATZ DES HERSTELLERS. DIE UNFALLVERHÜTUNGSVORSCHRIFTEN DES ARBEITGEBERS SIND EBENFALLS ZU BEACHTEN.**

|   |  |   |  |
|---|--|---|--|
|   |    |    |  |
| <ul style="list-style-type: none"> <li>● Keep your head out of fumes.</li> <li>● Use ventilation or exhaust to remove fumes from breathing zone.</li> </ul>                                   | <ul style="list-style-type: none"> <li>● Turn power off before servicing.</li> </ul>   | <ul style="list-style-type: none"> <li>● Do not operate with panel open or guards off.</li> </ul>   | <b>WARNING</b>   |
| <ul style="list-style-type: none"> <li>● Los humos fuera de la zona de respiración.</li> <li>● Mantenga la cabeza fuera de los humos. Utilice ventilación o aspiración para gases.</li> </ul> | <ul style="list-style-type: none"> <li>● Desconectar el cable de alimentación de poder de la máquina antes de iniciar cualquier servicio.</li> </ul>   | <ul style="list-style-type: none"> <li>● No operar con panel abierto o guardas quitadas.</li> </ul>   | Spanish<br><b>AVISO DE PRECAUCION</b>  |
| <ul style="list-style-type: none"> <li>● Gardez la tête à l'écart des fumées.</li> <li>● Utilisez un ventilateur ou un aspirateur pour ôter les fumées des zones de travail.</li> </ul>       | <ul style="list-style-type: none"> <li>● Débranchez le courant avant l'entretien.</li> </ul>   | <ul style="list-style-type: none"> <li>● N'opérez pas avec les panneaux ouverts ou avec les dispositifs de protection enlevés.</li> </ul>                       | French<br><b>ATTENTION</b>   |
| <ul style="list-style-type: none"> <li>● Vermeiden Sie das Einatmen von Schweißrauch!</li> <li>● Sorgen Sie für gute Be- und Entlüftung des Arbeitsplatzes!</li> </ul>                        | <ul style="list-style-type: none"> <li>● Strom vor Wartungsarbeiten abschalten! (Netzstrom völlig öffnen; Maschine anhalten!)</li> </ul>   | <ul style="list-style-type: none"> <li>● Anlage nie ohne Schutzgehäuse oder Innenschutzverkleidung in Betrieb setzen!</li> </ul>                                | German<br><b>WARNUNG</b>   |
| <ul style="list-style-type: none"> <li>● Mantenha seu rosto da fumaça.</li> <li>● Use ventilação e exaustão para remover fumo da zona respiratória.</li> </ul>                                | <ul style="list-style-type: none"> <li>● Não opere com as tampas removidas.</li> <li>● Desligue a corrente antes de fazer serviço.</li> <li>● Não toque as partes elétricas nuas.</li> </ul> | <ul style="list-style-type: none"> <li>● Mantenha-se afastado das partes moventes.</li> <li>● Não opere com os painéis abertos ou guardas removidas.</li> </ul> | Portuguese<br><b>ATENÇÃO</b>   |
| <ul style="list-style-type: none"> <li>● ヒュームから頭を離すようにして下さい。</li> <li>● 換気や排煙に十分留意して下さい。</li> </ul>   | <ul style="list-style-type: none"> <li>● メンテナンス・サービスに取りかかる際には、まず電源スイッチを必ず切ってください。</li> </ul>   | <ul style="list-style-type: none"> <li>● パネルやカバーを取り外したまま機械操作をしないで下さい。</li> </ul>  | Japanese<br><b>注意事項</b>  |
| <ul style="list-style-type: none"> <li>● 頭部遠離煙霧。</li> <li>● 在呼吸區使用通風或排風器除煙。</li> </ul>  | <ul style="list-style-type: none"> <li>● 維修前切斷電源。</li> </ul>   | <ul style="list-style-type: none"> <li>● 儀表板打開或沒有安全罩時不準作業。</li> </ul>   | Chinese<br><b>警告</b>   |
| <ul style="list-style-type: none"> <li>● 얼굴로부터 용접가스를 멀리하십시오.</li> <li>● 호흡지역으로부터 용접가스를 제거하기 위해 가스제거기나 통풍기를 사용하십시오.</li> </ul>   | <ul style="list-style-type: none"> <li>● 보수전에 전원을 차단하십시오.</li> </ul>   | <ul style="list-style-type: none"> <li>● 판넬이 열린 상태로 작동치 마십시오.</li> </ul>  | Korean<br><b>위험</b>  |
| <ul style="list-style-type: none"> <li>● ابعد رأسك بعيداً عن الدخان.</li> <li>● استعمل التهوية أو جهاز ضغط الدخان للخارج لكي تبعد الدخان عن المنطقة التي تتنفس فيها.</li> </ul>               | <ul style="list-style-type: none"> <li>● أقطع التيار الكهربائي قبل القيام بأية صيانة.</li> </ul>   | <ul style="list-style-type: none"> <li>● لا تشغيل هذا الجهاز اذا كانت الاغطية الحديدية الواقية ليست عليه.</li> </ul>  | Arabic<br><b>تحذير</b>   |

**LEIA E COMPREENDA AS INSTRUÇÕES DO FABRICANTE PARA ESTE EQUIPAMENTO E AS PARTES DE USO, E SIGA AS PRÁTICAS DE SEGURANÇA DO EMPREGADOR.**

使う機械や溶材のメーカーの指示書をよく読み、まず理解して下さい。そして貴社の安全規定に従って下さい。

請詳細閱讀並理解製造廠提供的說明以及應該使用的銀焊材料，並請遵守貴方的有閣勞動保護規定。

이 제품에 동봉된 작업지침서를 숙지하시고 귀사의 작업자 안전수칙을 준수하시기 바랍니다.

اقرأ بتمعن وافهم تعليمات المصنع المنتج لهذه المعدات والمواد قبل استعمالها واتبع تعليمات الوقاية لصاحب العمل.



• World's Leader in Welding and Cutting Products •

• Sales and Service through Subsidiaries and Distributors Worldwide •

Cleveland, Ohio 44117-1199 U.S.A. TEL: 216.481.8100 FAX: 216.486.1751 WEB SITE: [www.lincolnelectric.com](http://www.lincolnelectric.com)