



20mm

CUTMASTER™

PLASMA CUTTING SYSTEM



Art # A-09206

Operating Manual

Rev. AH

Date: April 25, 2012

Manual # 0-5078



60
AMP

DC

1
PHASE

3
PHASE

380-
400
V



WE APPRECIATE YOUR BUSINESS!

Congratulations on your new Thermal Dynamics product. We are proud to have you as our customer and will strive to provide you with the best service and reliability in the industry. This product is backed by our extensive warranty and world-wide service network. To locate your nearest distributor or service agency call 1-800-426-1888, or visit us on the web at www.thermal-dynamics.com.

This Operating Manual has been designed to instruct you on the correct use and operation of your Thermal Dynamics product. Your satisfaction with this product and its safe operation is our ultimate concern. Therefore please take the time to read the entire manual, especially the Safety Precautions. They will help you to avoid potential hazards that may exist when working with this product.

YOU ARE IN GOOD COMPANY!

The Brand of Choice for Contractors and Fabricators Worldwide.

Thermal Dynamics is a Global Brand of manual and automation Plasma Cutting Products for Thermadyne Industries Inc.

We distinguish ourselves from our competition through market-leading, dependable products that have stood the test of time. We pride ourselves on technical innovation, competitive prices, excellent delivery, superior customer service and technical support, together with excellence in sales and marketing expertise.

Above all, we are committed to developing technologically advanced products to achieve a safer working environment within the welding industry.



WARNING

Read and understand this entire Manual and your employer's safety practices before installing, operating, or servicing the equipment.

While the information contained in this Manual represents the Manufacturer's best judgement, the Manufacturer assumes no liability for its use.

Plasma Cutting Power Supply
CutMaster™ 20mm
SL60 1Torch™
Operating Manual Number 0-5078

Published by:
Thermal Dynamics Corporation
82 Benning Street
West Lebanon, New Hampshire, USA 03784
(603) 298-5711

www.thermal-dynamics.com

Copyright 2008, 2009, 2010, 2011, 2012 by
Thermadyne Corporation

All rights reserved.

Reproduction of this work, in whole or in part, without written permission of the publisher is prohibited.

The publisher does not assume and hereby disclaims any liability to any party for any loss or damage caused by any error or omission in this Manual, whether such error results from negligence, accident, or any other cause.

Original Publication Date: September 26, 2008

Revision Date: April 25, 2012

Record the following information for Warranty purposes:

Where Purchased: _____

Purchase Date: _____

Power Supply Serial #: _____

Torch Serial #: _____

This Page Intentionally Blank

TABLE OF CONTENTS

| | |
|--|-------|
| SECTION 1: GENERAL INFORMATION | 1-1 |
| 1.01 Notes, Cautions and Warnings | 1-1 |
| 1.02 Important Safety Precautions | 1-1 |
| 1.03 Publications | 1-2 |
| 1.04 Note, Attention et Avertissement | 1-3 |
| 1.05 Precautions De Securite Importantes | 1-3 |
| 1.06 Documents De Reference | 1-5 |
| 1.07 Declaration of Conformity | 1-6 |
| 1.08 Statement of Warranty | 1-7 |
| SECTION 2 SYSTEM: INTRODUCTION | 2-1 |
| 2.01 How To Use This Manual | 2-1 |
| 2.02 Equipment Identification | 2-1 |
| 2.03 Receipt Of Equipment..... | 2-1 |
| 2.04 Power Supply Specifications | 2-2 |
| 2.05 Input Wiring Specifications | 2-3 |
| 2.06 Power Supply Features | 2-4 |
| SECTION 2 TORCH: INTRODUCTION | 2T-1 |
| 2T.01 Scope of Manual..... | 2T-1 |
| 2T.02 General Description | 2T-1 |
| 2T.03 Specifications | 2T-1 |
| 2T.04 Options And Accessories..... | 2T-2 |
| 2T.05 Introduction to Plasma..... | 2T-2 |
| SECTION 3 SYSTEM: INSTALLATION | 3-1 |
| 3.01 Unpacking..... | 3-1 |
| 3.02 Lifting Options..... | 3-1 |
| 3.03 Primary Input Power Connections | 3-1 |
| 3.04 Gas Connections | 3-2 |
| SECTION 3 TORCH: INSTALLATION | 3T-1 |
| 3T.01 Torch Connections..... | 3T-1 |
| 3T.02 Setting Up Mechanical Torch..... | 3T-1 |
| SECTION 4 SYSTEM: OPERATION..... | 4-1 |
| 4.01 Front Panel Controls / Features..... | 4-1 |
| 4.02 Preparations for Operation | 4-2 |
| SECTION 4 TORCH: OPERATION..... | 4T-1 |
| 4T.01 Torch Parts Selection | 4T-1 |
| 4T.02 Cut Quality | 4T-2 |
| 4T.03 General Cutting Information..... | 4T-2 |
| 4T.04 Hand Torch Operation | 4T-3 |
| 4T.05 Gouging | 4T-6 |
| 4T.06 Mechanized Torch Operation | 4T-7 |
| 4T.07 Parts Selection for SL60 Torch Cutting | 4T-9 |
| 4T.08 Recommended Cutting Speeds for SL60 Torch With Exposed Tip..... | 4T-10 |
| 4T.09 Recommended Cutting Speeds for SL60 Torch With Shielded Tip..... | 4T-13 |
| PATENT INFORMATION | 4T-16 |

TABLE OF CONTENTS

| | |
|--|------------|
| SECTION 5 SYSTEM: SERVICE | 5-1 |
| 5.01 General Maintenance | 5-1 |
| 5.02 Maintenance Schedule | 5-2 |
| 5.03 Common Faults | 5-2 |
| 5.04 Fault Indicator | 5-3 |
| 5.05 Basic Troubleshooting Guide..... | 5-4 |
| 5.06 Power Supply Basic Parts Replacement | 5-6 |
| SECTION 5 TORCH: SERVICE..... | 5T-1 |
| 5T.01 General Maintenance | 5T-1 |
| 5T.02 Inspection and Replacement of Consumable Torch Parts | 5T-2 |
| SECTION 6: PARTS LISTS..... | 6-1 |
| 6.01 Introduction | 6-1 |
| 6.02 Ordering Information..... | 6-1 |
| 6.03 Power Supply Replacement | 6-1 |
| 6.04 Replacement Power Supply Parts | 6-2 |
| 6.05 Options and Accessories | 6-2 |
| 6.06 Replacement Parts for Hand Torch | 6-3 |
| 6.07 Replacement Parts - for Machine Torches with Unshielded Leads | 6-4 |
| 6.08 Replacement Shielded Machine Torch Leads Assemblies | 6-6 |
| 6.09 Torch Consumable Parts (SL60) | 6-7 |
| 6.10 Torch Consumable Parts (SL100) | 6-8 |
| APPENDIX 1: SEQUENCE OF OPERATION (BLOCK DIAGRAM) | A-1 |
| APPENDIX 2: DATA TAG INFORMATION | A-2 |
| APPENDIX 3: TORCH PIN - OUT DIAGRAMS..... | A-3 |
| APPENDIX 4: TORCH CONNECTION DIAGRAMS | A-4 |
| APPENDIX 5: SYSTEM SCHEMATIC, 380/400/415V UNITS | A-6 |
| APPENDIX 6: Publication History..... | A-8 |
| GLOBAL CUSTOMER SERVICE CONTACT INFORMATION | Rear Cover |

SECTION 1: GENERAL INFORMATION

1.01 Notes, Cautions and Warnings

Throughout this manual, notes, cautions, and warnings are used to highlight important information. These highlights are categorized as follows:

NOTE

An operation, procedure, or background information which requires additional emphasis or is helpful in efficient operation of the system.



CAUTION

A procedure which, if not properly followed, may cause damage to the equipment.



WARNING

A procedure which, if not properly followed, may cause injury to the operator or others in the operating area.



WARNING

Gives information regarding possible electrical shock injury. Warnings will be enclosed in a box such as this.

1.02 Important Safety Precautions



WARNING

OPERATION AND MAINTENANCE OF PLASMA ARC EQUIPMENT CAN BE DANGEROUS AND HAZARDOUS TO YOUR HEALTH.

Plasma arc cutting produces intense electric and magnetic emissions that may interfere with the proper function of cardiac pacemakers, hearing aids, or other electronic health equipment. Persons who work near plasma arc cutting applications should consult their medical health professional and the manufacturer of the health equipment to determine whether a hazard exists.

To prevent possible injury, read, understand and follow all warnings, safety precautions and instructions before using the equipment. Call 1-603-298-5711 or your local distributor if you have any questions.



GASES AND FUMES

Gases and fumes produced during the plasma cutting process can be dangerous and hazardous to your health.

- Keep all fumes and gases from the breathing area. Keep your head out of the welding fume plume.
- Use an air-supplied respirator if ventilation is not adequate to remove all fumes and gases.
- The kinds of fumes and gases from the plasma arc depend on the kind of metal being used, coatings on the metal, and the different processes. You must be very careful when cutting or welding any metals which may contain one or more of the following:

| | | |
|-----------|-----------|----------|
| Antimony | Chromium | Mercury |
| Arsenic | Cobalt | Nickel |
| Barium | Copper | Selenium |
| Beryllium | Lead | Silver |
| Cadmium | Manganese | Vanadium |

- Always read the Material Safety Data Sheets (MSDS) that should be supplied with the material you are using. These MSDSs will give you the information regarding the kind and amount of fumes and gases that may be dangerous to your health.
- For information on how to test for fumes and gases in your workplace, refer to item 1 in Subsection 1.03, Publications in this manual.
- Use special equipment, such as water or down draft cutting tables, to capture fumes and gases.
- Do not use the plasma torch in an area where combustible or explosive gases or materials are located.
- Phosgene, a toxic gas, is generated from the vapors of chlorinated solvents and cleansers. Remove all sources of these vapors.
- This product, when used for welding or cutting, produces fumes or gases which contain chemicals known to the State of California to cause birth defects and, in some cases, cancer. (California Health & Safety Code Sec. 25249.5 et seq.)



ELECTRIC SHOCK

Electric Shock can injure or kill. The plasma arc process uses and produces high voltage electrical energy. This electric energy can cause severe or fatal shock to the operator or others in the workplace.

- Never touch any parts that are electrically “live” or “hot.”
- Wear dry gloves and clothing. Insulate yourself from the work piece or other parts of the welding circuit.
- Repair or replace all worn or damaged parts.
- Extra care must be taken when the workplace is moist or damp.
- Install and maintain equipment according to NEC code, refer to item 9 in Subsection 1.03, Publications.
- Disconnect power source before performing any service or repairs.
- Read and follow all the instructions in the Operating Manual.



FIRE AND EXPLOSION

Fire and explosion can be caused by hot slag, sparks, or the plasma arc.

- Be sure there is no combustible or flammable material in the workplace. Any material that cannot be removed must be protected.

CUTMASTER 20mm

- Ventilate all flammable or explosive vapors from the workplace.
- Do not cut or weld on containers that may have held combustibles.
- Provide a fire watch when working in an area where fire hazards may exist.
- Hydrogen gas may be formed and trapped under aluminum workpieces when they are cut underwater or while using a water table. **DO NOT** cut aluminum alloys underwater or on a water table unless the hydrogen gas can be eliminated or dissipated. Trapped hydrogen gas that is ignited will cause an explosion.



NOISE

Noise can cause permanent hearing loss. Plasma arc processes can cause noise levels to exceed safe limits. You must protect your ears from loud noise to prevent permanent loss of hearing.

- To protect your hearing from loud noise, wear protective ear plugs and/or ear muffs. Protect others in the workplace.
- Noise levels should be measured to be sure the decibels (sound) do not exceed safe levels.
- For information on how to test for noise, see item 1 in Subsection 1.03, Publications, in this manual.



PLASMA ARC RAYS

Plasma Arc Rays can injure your eyes and burn your skin. The plasma arc process produces very bright ultra violet and infra red light. These arc rays will damage your eyes and burn your skin if you are not properly protected.

- To protect your eyes, always wear a welding helmet or shield. Also always wear safety glasses with side shields, goggles or other protective eye wear.
- Wear welding gloves and suitable clothing to protect your skin from the arc rays and sparks.
- Keep helmet and safety glasses in good condition. Replace lenses when cracked, chipped or dirty.
- Protect others in the work area from the arc rays. Use protective booths, screens or shields.
- Use the shade of lens as suggested in the following per ANSI/ASC Z49.1:

| Minimum Protective Arc Current | Suggested Shade No. | Shade No. |
|--------------------------------|---------------------|-----------|
| Less Than 300* | 8 | 9 |
| 300 - 400* | 9 | 12 |
| 400 - 800* | 10 | 14 |

* These values apply where the actual arc is clearly seen. Experience has shown that lighter filters may be used when the arc is hidden by the workpiece.



LEAD WARNING

This product contains chemicals, including lead, or otherwise produces chemicals known to the State of California to cause cancer, birth defects and other reproductive harm. **Wash hands after handling.** (California Health & Safety Code § 25249.5 et seq.)

1.03 Publications

Refer to the following standards or their latest revisions for more information:

1. OSHA, SAFETY AND HEALTH STANDARDS, 29CFR 1910, obtainable from the Superintendent of Documents, U.S. Government Printing Office, Washington, D.C. 20402
2. ANSI Standard Z49.1, SAFETY IN WELDING AND CUTTING, obtainable from the American Welding Society, 550 N.W. LeJeune Rd, Miami, FL 33126
3. NIOSH, SAFETY AND HEALTH IN ARC WELDING AND GAS WELDING AND CUTTING, obtainable from the Superintendent of Documents, U.S. Government Printing Office, Washington, D.C. 20402
4. ANSI Standard Z87.1, SAFE PRACTICES FOR OCCUPATION AND EDUCATIONAL EYE AND FACE PROTECTION, obtainable from American National Standards Institute, 1430 Broadway, New York, NY 10018
5. ANSI Standard Z41.1, STANDARD FOR MEN'S SAFETY-TOE FOOTWEAR, obtainable from the American National Standards Institute, 1430 Broadway, New York, NY 10018
6. ANSI Standard Z49.2, FIRE PREVENTION IN THE USE OF CUTTING AND WELDING PROCESSES, obtainable from American National Standards Institute, 1430 Broadway, New York, NY 10018
7. AWS Standard A6.0, WELDING AND CUTTING CONTAINERS WHICH HAVE HELD COMBUSTIBLES, obtainable from American Welding Society, 550 N.W. LeJeune Rd, Miami, FL 33126
8. NFPA Standard 51, OXYGEN-FUEL GAS SYSTEMS FOR WELDING, CUTTING AND ALLIED PROCESSES, obtainable from the National Fire Protection Association, Batterymarch Park, Quincy, MA 02269
9. NFPA Standard 70, NATIONAL ELECTRICAL CODE, obtainable from the National Fire Protection Association, Batterymarch Park, Quincy, MA 02269
10. NFPA Standard 51B, CUTTING AND WELDING PROCESSES, obtainable from the National Fire Protection Association, Batterymarch Park, Quincy, MA 02269
11. CGA Pamphlet P-1, SAFE HANDLING OF COMPRESSED GASES IN CYLINDERS, obtainable from the Compressed Gas Association, 1235 Jefferson Davis Highway, Suite 501, Arlington, VA 22202
12. CSA Standard W117.2, CODE FOR SAFETY IN WELDING AND CUTTING, obtainable from the Canadian Standards Association, Standards Sales, 178 Rexdale Boulevard, Rexdale, Ontario, Canada M9W 1R3
13. NWSA booklet, WELDING SAFETY BIBLIOGRAPHY obtainable from the National Welding Supply Association, 1900 Arch Street, Philadelphia, PA 19103
14. American Welding Society Standard AWSF4.1, RECOMMENDED SAFE PRACTICES FOR THE PREPARATION FOR WELDING AND CUTTING OF CONTAINERS AND PIPING THAT HAVE HELD HAZARDOUS SUBSTANCES, obtainable from the American Welding Society, 550 N.W. LeJeune Rd, Miami, FL 33126
15. ANSI Standard Z88.2, PRACTICE FOR RESPIRATORY PROTECTION, obtainable from American National Standards Institute, 1430 Broadway, New York, NY 10018

1.04 Note, Attention et Avertissement

Dans ce manuel, les mots “note,” “attention,” et “avertissement” sont utilisés pour mettre en relief des informations à caractère important. Ces mises en relief sont classifiées comme suit :

NOTE

Toute opération, procédure ou renseignement général sur lequel il importe d'insister davantage ou qui contribue à l'efficacité de fonctionnement du système.



ATTENTION

Toute procédure pouvant résulter l'endommagement du matériel en cas de non-respect de la procédure en question.



AVERTISSEMENT

Toute procédure pouvant provoquer des blessures de l'opérateur ou des autres personnes se trouvant dans la zone de travail en cas de non-respect de la procédure en question.



AVERTISSEMENT

Fournit l'information concernant des dommages possibles de choc électrique. Des avertissements seront enfermés dans une boîte de ce type.

1.05 Précautions De Sécurité Importantes



AVERTISSEMENTS

L'OPÉRATION ET LA MAINTENANCE DU MATÉRIEL DE SOUDAGE À L'ARC AU JET DE PLASMA PEUVENT PRÉSENTER DES RISQUES ET DES DANGERS DE SANTÉ.

Coupant à l'arc au jet de plasma produit de l'énergie électrique haute tension et des émissions magnétique qui peuvent interférer la fonction propre d'un "pacemaker" cardiaque, les appareils auditif, ou autre matériel de santé électronique. Ceux qui travail près d'une application à l'arc au jet de plasma devrait consulter leur membre professionnel de médication et le manufacturier de matériel de santé pour déterminer s'il existe des risques de santé.

Il faut communiquer aux opérateurs et au personnel TOUS les dangers possibles. Afin d'éviter les blessures possibles, lisez, comprenez et suivez tous les avertissements, toutes les précautions de sécurité et toutes les consignes avant d'utiliser le matériel. Composez le + 603-298-5711 ou votre distributeur local si vous avez des questions.



FUMÉE et GAZ

La fumée et les gaz produits par le procédé de jet de plasma peuvent présenter des risques et des dangers de santé.

- Eloignez toute fumée et gaz de votre zone de respiration. Gardez votre tête hors de la plume de fumée provenant du chalumeau.
- Utilisez un appareil respiratoire à alimentation en air si l'aération fournie ne permet pas d'éliminer la fumée et les gaz.
- Les sortes de gaz et de fumée provenant de l'arc de plasma dépendent du genre de métal utilisé, des revêtements se trouvant sur le métal et des différents procédés. Vous devez prendre soin lorsque vous coupez ou soudez tout métal pouvant contenir un ou plusieurs des éléments suivants:

| | | |
|-----------|-----------|----------|
| antimoine | cadmium | mercure |
| argent | chrome | nickel |
| arsenic | cobalt | plomb |
| baryum | cuivre | sélénium |
| béryllium | manganèse | vanadium |

- Lisez toujours les fiches de données sur la sécurité des matières (sigle américain “MSDS”); celles-ci devraient être fournies avec le matériel que vous utilisez. Les MSDS contiennent des renseignements quant à la quantité et la nature de la fumée et des gaz pouvant poser des dangers de santé.
- Pour des informations sur la manière de tester la fumée et les gaz de votre lieu de travail, consultez l'article 1 et les documents cités à la page 5.
- Utilisez un équipement spécial tel que des tables de coupe à débit d'eau ou à courant descendant pour capter la fumée et les gaz.
- N'utilisez pas le chalumeau au jet de plasma dans une zone où se trouvent des matières ou des gaz combustibles ou explosifs.
- Le phosgène, un gaz toxique, est généré par la fumée provenant des solvants et des produits de nettoyage chlorés. Éliminez toute source de telle fumée.
- Ce produit, dans le procédé de soudage et de coupe, produit de la fumée ou des gaz pouvant contenir des éléments reconnu dans L'état de la Californie, qui peuvent causer des défauts de naissance et le cancer. (La sécurité de santé en Californie et la code sécurité Sec. 25249.5 et seq.)



CHOC ELECTRIQUE

Les chocs électriques peuvent blesser ou même tuer. Le procédé au jet de plasma requiert et produit de l'énergie électrique haute tension. Cette énergie électrique peut produire des chocs graves, voire mortels, pour l'opérateur et les autres personnes sur le lieu de travail.

- Ne touchez jamais une pièce “sous tension” ou “vive”; portez des gants et des vêtements secs. Isolez-vous de la pièce de travail ou des autres parties du circuit de soudage.
- Réparez ou remplacez toute pièce usée ou endommagée.
- Prenez des soins particuliers lorsque la zone de travail est humide ou moite.
- Montez et maintenez le matériel conformément au Code électrique national des Etats-Unis. (Voir la page 5, article 9.)
- Débranchez l'alimentation électrique avant tout travail d'entretien ou de réparation.
- Lisez et respectez toutes les consignes du Manuel de consignes.



INCENDIE ET EXPLOSION

Les incendies et les explosions peuvent résulter des scories chaudes, des étincelles ou de l'arc de plasma. Le procédé à l'arc de plasma produit du métal, des étincelles, des scories chaudes pouvant mettre le feu aux matières combustibles ou provoquer l'explosion de fumées inflammables.

- Soyez certain qu'aucune matière combustible ou inflammable ne se trouve sur le lieu de travail. Protégez toute telle matière qu'il est impossible de retirer de la zone de travail.
- Procurez une bonne aération de toutes les fumées inflammables ou explosives.
- Ne coupez pas et ne soudez pas les conteneurs ayant pu renfermer des matières combustibles.
- Prévoyez une veille d'incendie lors de tout travail dans une zone présentant des dangers d'incendie.
- Le gas hydrogène peut se former ou s'accumuler sous les pièces de travail en aluminium lorsqu'elles sont coupées sous l'eau ou sur une table d'eau. NE PAS couper les alliages en aluminium sous l'eau ou sur une table d'eau à moins que le gas hydrogène peut s'échapper ou se dissiper. Le gas hydrogène accumulé explosera si enflammé.



RAYONS D'ARC DE PLASMA

Les rayons provenant de l'arc de plasma peuvent blesser vos yeux et brûler votre peau. Le procédé à l'arc de plasma produit une lumière infra-rouge et des rayons ultra-violet très forts. Ces rayons d'arc nuiront à vos yeux et brûleront votre peau si vous ne vous protégez pas correctement.

- Pour protéger vos yeux, portez toujours un casque ou un écran de soudeur. Portez toujours des lunettes de sécurité munies de parois latérales ou des lunettes de protection ou une autre sorte de protection oculaire.
- Portez des gants de soudeur et un vêtement protecteur approprié pour protéger votre peau contre les étincelles et les rayons de l'arc.
- Maintenez votre casque et vos lunettes de protection en bon état. Remplacez toute lentille sale ou comportant fissure ou rognure.
- Protégez les autres personnes se trouvant sur la zone de travail contre les rayons de l'arc en fournissant des cabines ou des écrans de protection.
- Utilisez la nuance de lentille qui est suggérée dans le recommandation qui suivent ANSI/ASC Z49.1:

| Nuance Minimum Courant Arc | Nuance Suggestée Protective Numéro | Numéro |
|-------------------------------|---------------------------------------|--------|
| Moins de 300* | 8 | 9 |
| 300 - 400* | 9 | 12 |
| 400 - 800* | 10 | 14 |

* Ces valeurs s'appliquent ou l'arc actuel est observé clairement. L'expérience a démontré que les filtres moins foncés peuvent être utilisés quand l'arc est caché par moicseau de travail.



BRUIT

Le bruit peut provoquer une perte permanente de l'ouïe. Les procédés de soudage à l'arc de plasma peuvent provoquer des niveaux sonores supérieurs aux limites normalement acceptables. Vous devez vous protéger les oreilles contre les bruits forts afin d'éviter une perte permanente de l'ouïe.

- Pour protéger votre ouïe contre les bruits forts, portez des tampons protecteurs et/ou des protections auriculaires. Protégez également les autres personnes se trouvant sur le lieu de travail.
- Il faut mesurer les niveaux sonores afin d'assurer que les décibels (le bruit) ne dépassent pas les niveaux sûrs.
- Pour des renseignements sur la manière de tester le bruit, consultez l'article 1, page 5.



PLOMB AVERTISSEMENT

Ce produit contient des produits chimiques, comme le plomb, ou engendre des produits chimiques, reconnus par l'état de Californie comme pouvant être à l'origine de cancer, de malformations fœtales ou d'autres problèmes de reproduction. **Il faut se laver les mains après toute manipulation.** (Code de Californie de la sécurité et santé, paragraphe 25249.5 et suivants)

1.06 Documents De Reference

Consultez les normes suivantes ou les révisions les plus récentes ayant été faites à celles-ci pour de plus amples renseignements :

1. OSHA, NORMES DE SÉCURITÉ DU TRAVAIL ET DE PROTECTION DE LA SANTÉ, 29CFR 1910, disponible auprès du Superintendent of Documents, U.S. Government Printing Office, Washington, D.C. 20402
2. Norme ANSI Z49.1, LA SÉCURITÉ DES OPÉRATIONS DE COUPE ET DE SOUDAGE, disponible auprès de la Société Américaine de Soudage (American Welding Society), 550 N.W. LeJeune Rd., Miami, FL 33126
3. NIOSH, LA SÉCURITÉ ET LA SANTÉ LORS DES OPÉRATIONS DE COUPE ET DE SOUDAGE À L'ARC ET AU GAZ, disponible auprès du Superintendent of Documents, U.S. Government Printing Office, Washington, D.C. 20402
4. Norme ANSI Z87.1, PRATIQUES SURES POUR LA PROTECTION DES YEUX ET DU VISAGE AU TRAVAIL ET DANS LES ECOLES, disponible de l'Institut Américain des Normes Nationales (American National Standards Institute), 1430 Broadway, New York, NY 10018
5. Norme ANSI Z41.1, NORMES POUR LES CHAUSSURES PROTECTRICES, disponible auprès de l'American National Standards Institute, 1430 Broadway, New York, NY 10018
6. Norme ANSI Z49.2, PRÉVENTION DES INCENDIES LORS DE L'EMPLOI DE PROCÉDÉS DE COUPE ET DE SOUDAGE, disponible auprès de l'American National Standards Institute, 1430 Broadway, New York, NY 10018
7. Norme A6.0 de l'Association Américaine du Soudage (AWS), LE SOUDAGE ET LA COUPE DE CONTENEURS AYANT RENFERMÉ DES PRODUITS COMBUSTIBLES, disponible auprès de la American Welding Society, 550 N.W. LeJeune Rd., Miami, FL 33126
8. Norme 51 de l'Association Américaine pour la Protection contre les Incendies (NFPA), LES SYSTEMES À GAZ AVEC ALIMENTATION EN OXYGENE POUR LE SOUDAGE, LA COUPE ET LES PROCÉDÉS ASSOCIÉS, disponible auprès de la National Fire Protection Association, Batterymarch Park, Quincy, MA 02269
9. Norme 70 de la NFPA, CODE ELECTRIQUE NATIONAL, disponible auprès de la National Fire Protection Association, Batterymarch Park, Quincy, MA 02269
10. Norme 51B de la NFPA, LES PROCÉDÉS DE COUPE ET DE SOUDAGE, disponible auprès de la National Fire Protection Association, Batterymarch Park, Quincy, MA 02269
11. Brochure GCA P-1, LA MANIPULATION SANS RISQUE DES GAZ COMPRIMÉS EN CYLINDRES, disponible auprès de l'Association des Gaz Comprimés (Compressed Gas Association), 1235 Jefferson Davis Highway, Suite 501, Arlington, VA 22202
12. Norme CSA W117.2, CODE DE SÉCURITÉ POUR LE SOUDAGE ET LA COUPE, disponible auprès de l'Association des Normes Canadiennes, Standards Sales, 178 Rexdale Boulevard, Rexdale, Ontario, Canada, M9W 1R3
13. Livret NWSA, BIBLIOGRAPHIE SUR LA SÉCURITÉ DU SOUDAGE, disponible auprès de l'Association Nationale de Fournitures de Soudage (National Welding Supply Association), 1900 Arch Street, Philadelphia, PA 19103
14. Norme AWSF4.1 de l'Association Américaine de Soudage, RECOMMANDATIONS DE PRATIQUES SURES POUR LA PRÉPARATION À LA COUPE ET AU SOUDAGE DE CONTENEURS ET TUYAUX AYANT RENFERMÉ DES PRODUITS DANGEREUX, disponible auprès de la American Welding Society, 550 N.W. LeJeune Rd., Miami, FL 33126
15. Norme ANSI Z88.2, PRATIQUES DE PROTECTION RESPIRATOIRE, disponible auprès de l'American National Standards Institute, 1430 Broadway, New York, NY 10018

CUTMASTER 20mm

1.07 Declaration of Conformity

Manufacturer: Thermal Dynamics Corporation
Address: 82 Benning Street
West Lebanon, New Hampshire 03784
USA

The equipment described in this manual conforms to all applicable aspects and regulations of the 'Low Voltage Directive' (2006/95 EC) and to the National legislation for the enforcement of this Directive.

The equipment described in this manual conforms to all applicable aspects and regulations of the "EMC Directive" (European Council Directive 89/336/EEC) and to the National legislation for the enforcement of this Directive.

Serial numbers are unique with each individual piece of equipment and details description, parts used to manufacture a unit and date of manufacture.

National Standard and Technical Specifications

The product is designed and manufactured to a number of standards and technical requirements. Among them are:

- * CSA (Canadian Standards Association) standard C22.2 number 60 for Arc welding equipment.
- * UL (Underwriters Laboratory) rating 94VO flammability testing for all printed-circuit boards used.
- * CENELEC EN50199 EMC Product Standard for Arc Welding Equipment.
- * ISO/IEC 60974-1 (BS 638-PT10) (EN 60 974-1) (EN50192) (EN50078) applicable to plasma cutting equipment and associated accessories.
- * For environments with increased hazard of electrical shock, Power Supplies bearing the 'S' mark conform to EN50192 when used in conjunction with hand torches with exposed cutting tips, if equipped with properly installed standoff guides.
- * Extensive product design verification is conducted at the manufacturing facility as part of the routine design and manufacturing process. This is to ensure the product is safe, when used according to instructions in this manual and related industry standards, and performs as specified. Rigorous testing is incorporated into the manufacturing process to ensure the manufactured product meets or exceeds all design specifications.

Thermal Dynamics has been manufacturing products for more than 30 years, and will continue to achieve excellence in our area of manufacture.

Manufacturers responsible representative: Steve Ward
Operations Director
Thermadyne Europe
Europa Building
Chorley N Industrial Park
Chorley, Lancashire,
England PR6 7BX



1.08 Statement of Warranty

LIMITED WARRANTY: Subject to the terms and conditions established below, Thermal Dynamics® Corporation warrants to the original retail purchaser that new Thermal Dynamics CUTMASTER™ 1Series plasma cutting systems sold after the effective date of this warranty are free of defects in material and workmanship. Should any failure to conform to this warranty appear within the applicable period stated below, Thermal Dynamics Corporation shall, upon notification thereof and substantiation that the product has been stored operated and maintained in accordance with Thermal Dynamics' specifications, instructions, recommendations and recognized industry practice, correct such defects by suitable repair or replacement.

This warranty is exclusive and in lieu of any warranty of merchantability or fitness for a particular purpose.

Thermal Dynamics will repair or replace, at its discretion, any warranted parts or components that fail due to defects in material or workmanship within the time periods set out below. Thermal Dynamics Corporation must be notified within 30 days of any failure, at which time Thermal Dynamics Corporation will provide instructions on the warranty procedures to be implemented.

Thermal Dynamics Corporation will honor warranty claims submitted within the warranty periods listed below. All warranty periods begin on the date of sale of the product to the original retail customer or 1 year after sale to an authorized Thermal Dynamics Distributor.

LIMITED WARRANTY PERIOD

| Product | Power Supply Components (Parts and Labor) | Torch and Leads (Parts and Labor) |
|-----------------|--|--------------------------------------|
| CUTMASTER™ 10mm | 3 Years | 1 Year |
| CUTMASTER™ 12mm | 3 Years | 1 Year |
| CUTMASTER™ 20mm | 3 Years | 1 Year |
| CUTMASTER™ 25mm | 3 Years | 1 Year |
| CUTMASTER™ 35mm | 3 Years | 1 Year |
| CUTMASTER™ 40mm | 3 Years | 1 Year |

This warranty does not apply to:

1. Consumable Parts, such as tips, electrodes, shield cups, o-rings, starter cartridges, gas distributors, fuses, filters.
2. Equipment that has been modified by an unauthorized party, improperly installed, improperly operated or misused based upon industry standards.

In the event of a claim under this warranty, the remedies shall be, at the discretion of Thermal Dynamics Corporation:

1. Repair of the defective product.
2. Replacement of the defective product.
3. Reimbursement of reasonable costs of repair when authorized in advance by Thermal Dynamics.
4. Payment of credit up to the purchase price less reasonable depreciation based on actual use.

These remedies may be authorized by Thermal Dynamics and are FOB West Lebanon, NH or an authorized Thermadyne service station. Product returned for service is at the owner's expense and no reimbursement of travel or transportation is authorized.

LIMITATION OF LIABILITY: Thermal Dynamics Corporation shall not under any circumstances be liable for special or consequential damages such as, but not limited to, damage or loss of purchased or replacement goods or claims of customer or distributors (hereinafter "Purchaser") for service interruption. The remedies of the Purchaser set forth herein are exclusive and the liability of Thermal Dynamics with respect to any contract, or anything done in connection therewith such as the performance or breach thereof, or from the manufacture, sale, delivery, resale, or use of the goods covered by or furnished by Thermal Dynamics whether arising out of contract, negligence, strict tort, or under any warranty, or otherwise, shall not, except as expressly provided herein, exceed the price of the goods upon which liability is based.

This warranty becomes invalid if replacement parts or accessories are used which may impair the safety or performance of any Thermal Dynamics product.

This warranty is invalid if the Thermal Dynamics product is sold by non - authorized persons.

Effective September 4, 2007

This Page Intentionally Blank

SECTION 2 SYSTEM: INTRODUCTION

2.01 How To Use This Manual

This Owner's Manual applies to just specification or part numbers listed on page i.

To ensure safe operation, read the entire manual, including the chapter on safety instructions and warnings.

Throughout this manual, the words **WARNING**, **CAUTION**, and **NOTE** may appear. Pay particular attention to the information provided under these headings. These special annotations are easily recognized as follows:

NOTE

An operation, procedure, or background information which requires additional emphasis or is helpful in efficient operation of the system.



CAUTION

A procedure which, if not properly followed, may cause damage to the equipment.



WARNING

A procedure which, if not properly followed, may cause injury to the operator or others in the operating area.



WARNING

Gives information regarding possible electrical shock injury. Warnings will be enclosed in a box such as this.

Additional copies of this manual may be purchased by contacting Thermadyne at the address and phone number in your area listed in the inside back cover of this manual. Include the Owner's Manual number and equipment identification numbers.

Electronic copies of this manual can also be downloaded at no charge in Acrobat PDF format by going to the Thermal Dynamics web site listed below and clicking on Thermal Dynamics and then on the Literature link:

<http://www.thermal-dynamics.com>

2.02 Equipment Identification

The unit's identification number (specification or part number), model, and serial number usually appear on a data tag attached to the rear panel. Equipment which does not have a data tag such as torch and cable assemblies are identified only by the specification or part number printed on loosely attached card or the shipping container. Record these numbers on the bottom of page i for future reference.

2.03 Receipt Of Equipment

When you receive the equipment, check it against the invoice to make sure it is complete and inspect the equipment for possible damage due to shipping. If there is any damage, notify the carrier immediately to file a claim. Furnish complete information concerning damage claims or shipping errors to the location in your area listed in the inside back cover of this manual.

Include all equipment identification numbers as described above along with a full description of the parts in error.

Move the equipment to the installation site before un-crating the unit. Use care to avoid damaging the equipment when using bars, hammers, etc., to un-crate the unit.

CUTMASTER 20mm

2.04 Power Supply Specifications

| CutMaster 20mm Power Supply Specifications | | | | | | | |
|--|---|-----|-----|-----|-----|------|-----|
| Input Power | 380 VAC (360 - 440 VAC), Three Phase, 50/60 Hz | | | | | | |
| | 400 VAC (360 - 440 VAC), Three Phase, 50/60 Hz | | | | | | |
| Input Power Cable | Power Supply includes input cable. Cable for 400V 3 Phase. | | | | | | |
| Output Current | 20 - 60 Amps, Continuously Adjustable | | | | | | |
| Power Supply Gas Filtering Ability | Particulates to 5 Microns | | | | | | |
| CutMaster 20mm Power Supply Duty Cycle * | | | | | | | |
| Ambient Temperature | Duty Cycle Ratings @ 40° C (104° F) Operating Range 0° - 50° C | | | | | | |
| All Units | Duty Cycle | 40% | | 60% | | 100% | |
| | Ratings | IEC | CE | IEC | CE | IEC | CE |
| | Current | 60A | 60A | 50A | 50A | 30A | 30A |
| | DC Voltage | 104 | 104 | 100 | 100 | 92 | 92 |
| * NOTE: The duty cycle will be reduced if the primary input power (AC) is low or the output voltage (DC) is higher than shown in this chart. | | | | | | | |

NOTE

IEC Rating is determined as specified by the International Electro-Technical Commission. These specifications include calculating an output voltage based upon power supply rated current. To facilitate comparison between power supplies, all manufacturers use this output voltage to determine duty cycle.

Power Supply Dimensions & Weight

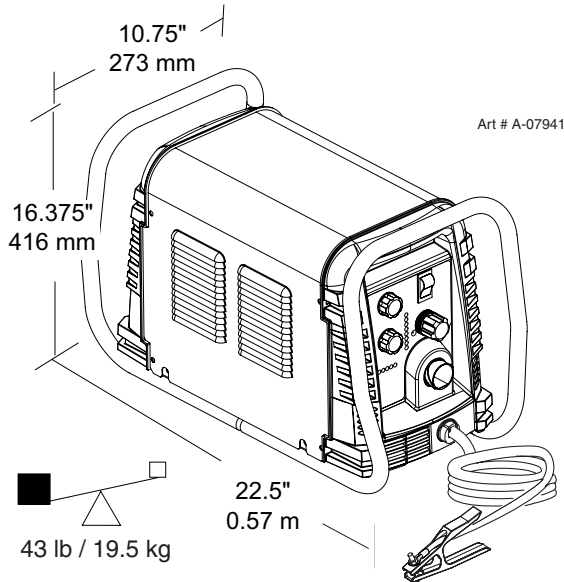

Ventilation Clearance Requirements

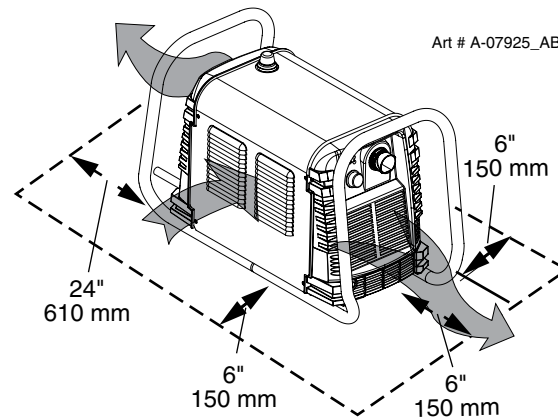

2.05 Input Wiring Specifications

| CutMaster 20mm Power Supply Input Cable Wiring Requirements | | | | | | | |
|--|---------------|-------|-------------|-------|-------|-----------------|---------------------|
| | Input voltage | Freq | Power Input | | | Suggested Sizes | |
| | Volts | Hz | kVA | I max | I eff | Fuse (amps) | Flexible Cord (AWG) |
| 3 Phase | 380 | 50/60 | 11 | 16 | 11 | 20 | 14 |
| | 400 | 50/60 | 11 | 16 | 11 | 20 | 14 |
| Line Voltages with Suggested Circuit Protection and Wire Sizes Based on National Electric Code and Canadian Electric Code | | | | | | | |

NOTE

*Refer to Local and National Codes or local authority having jurisdiction for proper wiring requirements.
Cable size is de-rated based on the Duty Cycle of the equipment.*

CUTMASTER 20mm

2.06 Power Supply Features

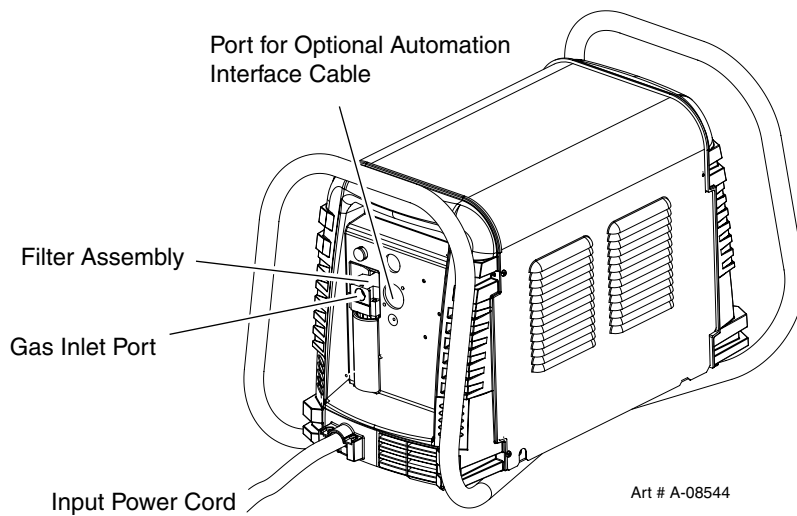
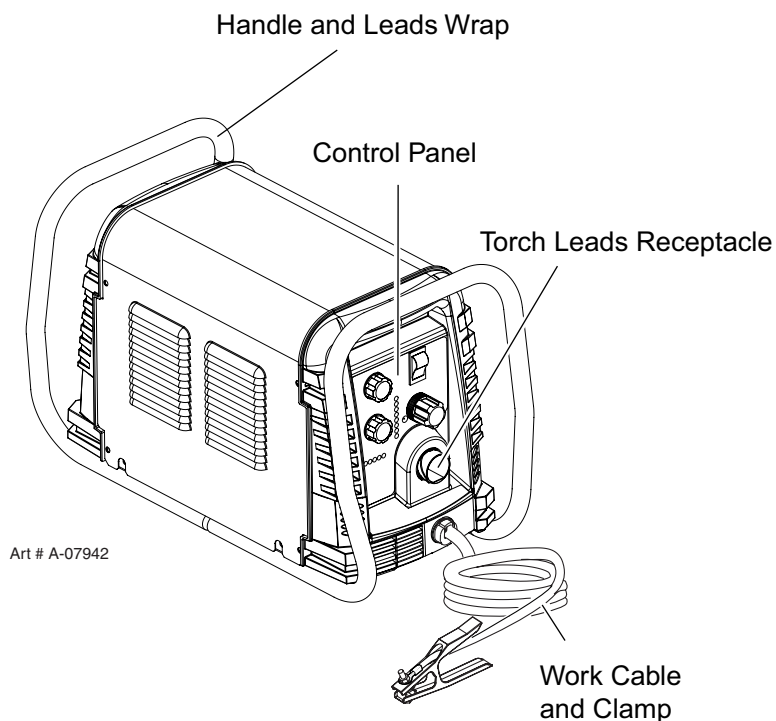

SECTION 2 TORCH: INTRODUCTION

2T.01 Scope of Manual

This manual contains descriptions, operating instructions and maintenance procedures for the 1 Torch Models SL60/Manual and SL100/Mechanized Plasma Cutting Torches. Service of this equipment is restricted to properly trained personnel; unqualified personnel are strictly cautioned against attempting repairs or adjustments not covered in this manual, at the risk of voiding the Warranty.

Read this manual thoroughly. A complete understanding of the characteristics and capabilities of this equipment will assure the dependable operation for which it was designed.

2T.02 General Description

Plasma torches are similar in design to the automotive spark plug. They consist of negative and positive sections separated by a center insulator. Inside the torch, the pilot arc starts in the gap between the negatively charged electrode and the positively charged tip. Once the pilot arc has ionized the plasma gas, the superheated column of gas flows through the small orifice in the torch tip, which is focused on the metal to be cut.

A single torch lead provides gas from a single source to be used as both the plasma and secondary gas. The air flow is divided inside the torch head. Single - gas operation provides a smaller sized torch and inexpensive operation.

NOTE

Refer to Section "2T.05 Introduction to Plasma" on page 2T-2, for a more detailed description of plasma torch operation.

Refer to the Appendix Pages for additional specifications as related to the Power Supply used.

2T.03 Specifications

A. Torch Configurations

1. Hand/Manual Torch, Models

The hand torch head is at 75° to the torch handle. The hand torches include a torch handle and torch trigger assembly.

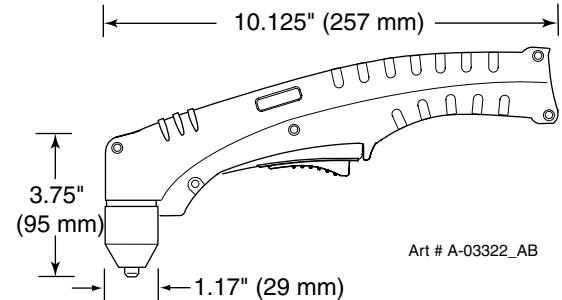

2. Mechanized Torch, Model

The standard machine torch has a positioning tube with rack & pinch block assembly.

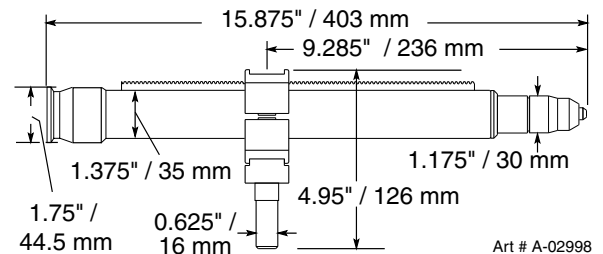

B. Torch Leads Lengths

Hand Torches are available as follows:

- 20 ft / 6.1 m, with ATC connectors
- 50 ft / 15.2 m, with ATC connectors

Machine Torches are available as follows:

- 5 foot / 1.5 m, with ATC connectors
- 10 foot / 3.05 m, with ATC connectors
- 25 foot / 7.6 m, with ATC connectors
- 50 foot / 15.2 m, with ATC connectors

C. Torch Parts

Starter Cartridge, Electrode, Tip, Shield Cup

D. Parts - In - Place (PIP)

Torch Head has built - in switch

12 VDC circuit rating

E. Type Cooling

Combination of ambient air and gas stream through torch.

CUTMASTER 20mm

F. Torch Ratings

| Manual Torch Ratings | |
|------------------------------|---------------------------|
| Ambient Temperature | 104° F 40° C |
| Duty Cycle | 100% @ 60 Amps @ 400 scfh |
| Maximum Current | 60 Amps |
| Voltage (V _{peak}) | 500V |
| Arc Striking Voltage | 7kV |

| Mechanized Torch Ratings | |
|------------------------------|----------------------------|
| Ambient Temperature | 104° F 40° C |
| Duty Cycle | 100% @ 100 Amps @ 400 scfh |
| Maximum Current | 120 Amps |
| Voltage (V _{peak}) | 500V |
| Arc Striking Voltage | 7kV |

G. Gas Requirements

| Manual and Mechanized Torch Gas Specifications | |
|--|---------------------------------|
| Gas (Plasma and Secondary) | Compressed Air |
| Operating Pressure Refer to NOTE | 60 - 95 psi 4.1 - 6.5 bar |
| Maximum Input Pressure | 125 psi / 8.6 bar |
| Gas Flow (Cutting and Gouging) | 300 - 500 scfh 142 - 235 lpm |



WARNING

This torch is not to be used with oxygen (O₂).

NOTE

Operating pressure varies with torch model, operating amperage, and torch leads length. Refer to gas pressure settings charts for each model.

H. Direct Contact Hazard

For standoff tip the recommended standoff is 3/16 inches / 4.7 mm.

2T.04 Options And Accessories

For options and accessories, see section 6.

2T.05 Introduction to Plasma

A. Plasma Gas Flow

Plasma is a gas which has been heated to an extremely high temperature and ionized so that it becomes electrically conductive. The plasma arc cutting and gouging processes use this plasma to transfer an electrical arc to the workpiece. The metal to be cut or removed is melted by the heat of the arc and then blown away.

While the goal of plasma arc cutting is separation of the material, plasma arc gouging is used to remove metals to a controlled depth and width.

In a Plasma Cutting Torch a cool gas enters Zone B, where a pilot arc between the electrode and the torch tip heats and ionizes the gas. The main cutting arc then transfers to the workpiece through the column of plasma gas in Zone C.

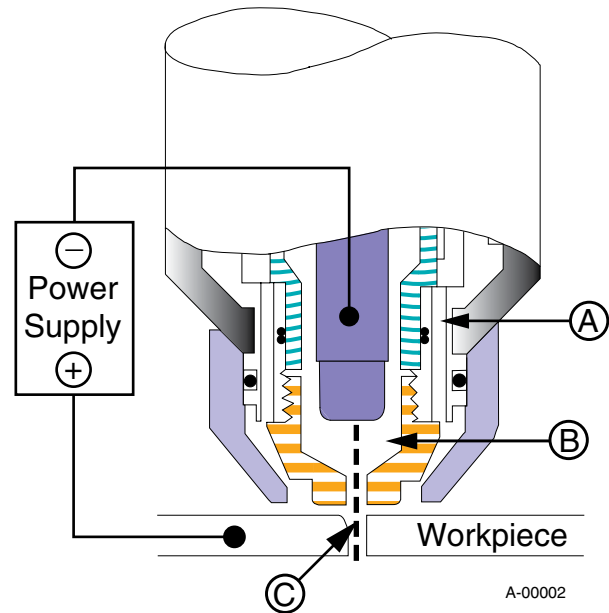

Typical Torch Head Detail

By forcing the plasma gas and electric arc through a small orifice, the torch delivers a high concentration of heat to a small area. The stiff, constricted plasma arc is shown in Zone C. Direct current (DC) straight polarity is used for plasma cutting, as shown in the illustration.

Zone A channels a secondary gas that cools the torch. This gas also assists the high velocity plasma gas in blowing the molten metal out of the cut allowing for a fast, slag - free cut.

B. Gas Distribution

The single gas used is internally split into plasma and secondary gases.

The plasma gas flows into the torch through the negative lead, through the starter cartridge, around the electrode, and out through the tip orifice.

The secondary gas flows down around the outside of the torch starter cartridge, and out between the tip and shield cup around the plasma arc.

C. Pilot Arc

When the torch is started a pilot arc is established between the electrode and cutting tip. This pilot arc creates a path for the main arc to transfer to the work.

D. Main Cutting Arc

DC power is also used for the main cutting arc. The negative output is connected to the torch electrode through the torch lead. The positive output is connected to the workpiece via the work cable and to the torch through a pilot wire.

E. Parts - In - Place (PIP)

The torch includes a 'Parts - In - Place' (PIP) circuit. When the shield cup is properly installed, it closes a switch. The torch will not operate if this switch is open.

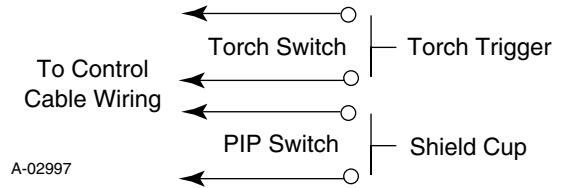

Parts - In - Place Circuit Diagram for Hand Torch

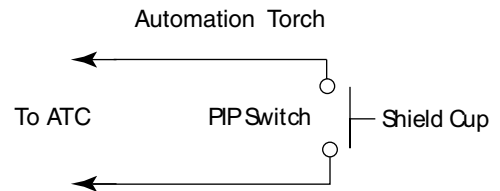
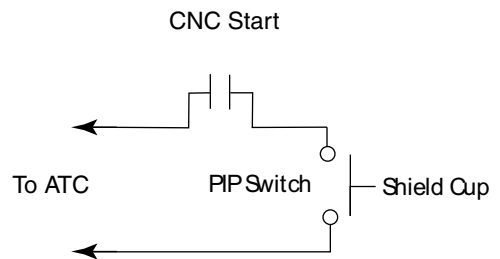
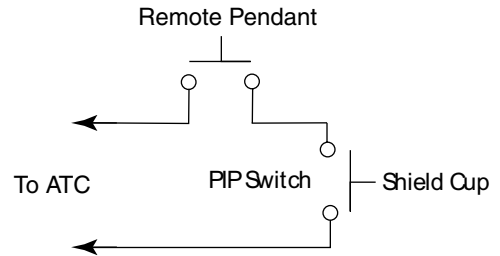

Parts - In - Place Circuit Diagram for Machine Torch

Art # A-08168

This Page Intentionally Blank

SECTION 3 SYSTEM: INSTALLATION

3.03 Primary Input Power Connections

3.01 Unpacking

1. Use the packing lists to identify and account for each item.
2. Inspect each item for possible shipping damage. If damage is evident, contact your distributor and / or shipping company before proceeding with the installation.
3. Record Power Supply and Torch model and serial numbers, purchase date and vendor name, in the information block at the front of this manual.

3.02 Lifting Options

The Power Supply includes a handle for **hand lifting only**. Be sure unit is lifted and transported safely and securely.



WARNING

Do not touch live electrical parts.

Disconnect input power cord before moving unit.

FALLING EQUIPMENT can cause serious personal injury and can damage equipment.

HANDLE is not for mechanical lifting.

- Only persons of adequate physical strength should lift the unit.
- Lift unit by the handles, using two hands. Do not use straps for lifting.
- Use optional cart or similar device of adequate capacity to move unit.
- Place unit on a proper skid and secure in place before transporting with a fork lift or other vehicle.



CAUTION

Check your power source for correct voltage before plugging in or connecting the unit. The primary power source, fuse, and any extension cords used must conform to local electrical code and the recommended circuit protection and wiring requirements as specified in Section 2.

All units are shipped from the factory with a 380/400Volt input power cable wired to the input contactor in the three - phase configuration. The following illustration and directions are for replacing the input power cable.

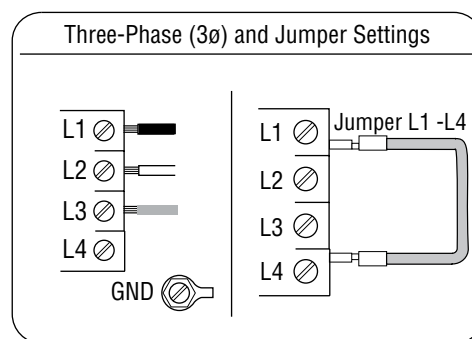

Art # A-08546

Three Phase Input Power Wiring

A. Connections to Three Phase Input Power



WARNING

Disconnect input power from the power supply and input cable before attempting this procedure.

These instructions are for replacing a 380/400V input power cable to the Power Supply for Three - Phase input power.

1. Remove the Power Supply cover per instructions found in section 5.
2. Disconnect the original input power cable from the main input contactor and the chassis ground connection.
3. Loosen the through - hole protector on the back panel of the power supply. Pull the original power cable out of the power supply.

- Using a customer supplied four - conductor input power cable for the voltage desired, strip back the insulation on the individual wires.
- Pass the cable being used through the access opening in the back panel of the power supply. Refer to Section 2 for power cable specifications.



CAUTION

The primary power source and power cable must conform to local electrical code and the recommended circuit protection and wiring requirements (refer to table in Section 2).

- Connect the wires as follows.
 - Set Jumper wires on the contactor. See previous illustrations.
 - Green / Yellow wire to Ground.
 - Remaining wires to L1 and L2 input. It does not matter what order these wires are attached.
- With a little slack in the wires, tighten the through - hole protector to secure the power cable.
- Reinstall the Power Supply cover per instructions found in section 5.
- Connect the opposite end of individual wires to a customer supplied plug or main disconnect.
- Connect the input power cable (or close the main disconnect switch) to supply power.

3.04 Gas Connections

Connecting Gas Supply to Unit

The connection is the same for compressed air or high pressure cylinders. Refer to the following two subsections if an optional air line filter is to be installed.

- Connect the air line to the inlet port. The illustration shows typical fittings as an example.

NOTE

For a secure seal, apply thread sealant to the fitting threads, according to manufacturer's instructions. Do not use Teflon tape as a thread sealer, as small particles of the tape may break off and block the small air passages in the torch.

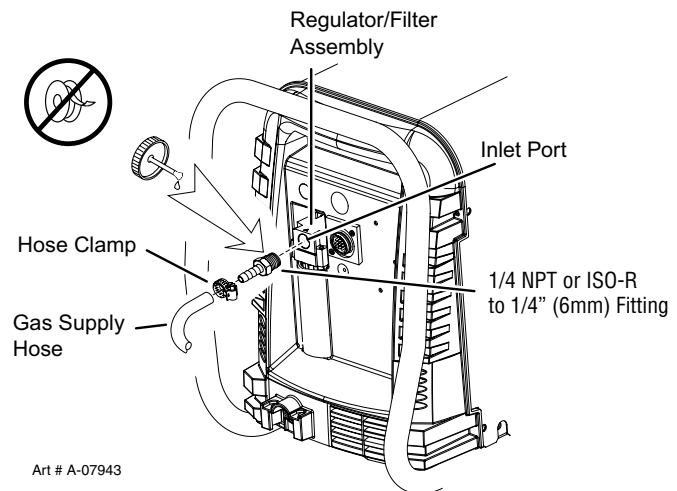

Air Connection to Inlet Port

Installing Optional Single - Stage Air Filter

An optional filter kit is recommended for improved filtering with compressed air, to keep moisture and debris out of the torch.

1. Attach the Single - Stage Filter Hose to the Inlet Port.
2. Attach the Filter Assembly to the filter hose.
3. Connect the air line to the Filter. The illustration shows typical fittings as an example.

NOTE

For a secure seal, apply thread sealant to the fitting threads, according to the maker's instructions. Do Not use Teflon tape as a thread sealer, as small particles of the tape may break off and block the small air passages in the torch. Connect as follows:

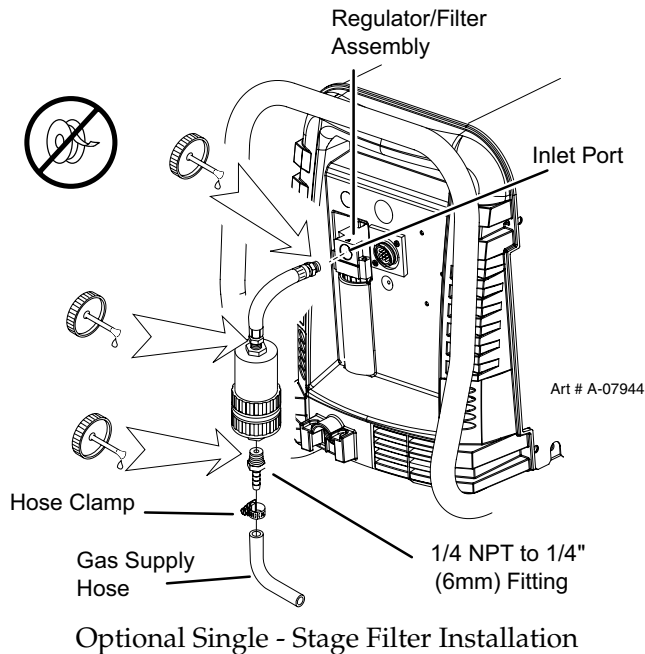

Optional Single - Stage Filter Installation

Installing Optional Two - Stage Air Filter Kit

This optional two - stage air line filter is also for use on compressed air shop systems. Filter removes moisture and contaminants to at least 5 microns.

Connect the air supply as follows:

1. Attach the Two Stage Filter bracket to the back of the power supply per instructions supplied with the filter assembly.

NOTE

For a secure seal, apply thread sealant to the fitting threads according to manufacturer's instructions. Do Not use Teflon tape as a thread sealer as small particles of the tape may break off and block the small air passages in the torch.

2. Connect the two stage filter outlet hose to the inlet port of the Regulator / Filter Assembly.
3. Use customer - supplied fittings to connect the air line to the Filter. A 1/4 NPT to 1/4" hose barbed fitting is shown as an example.

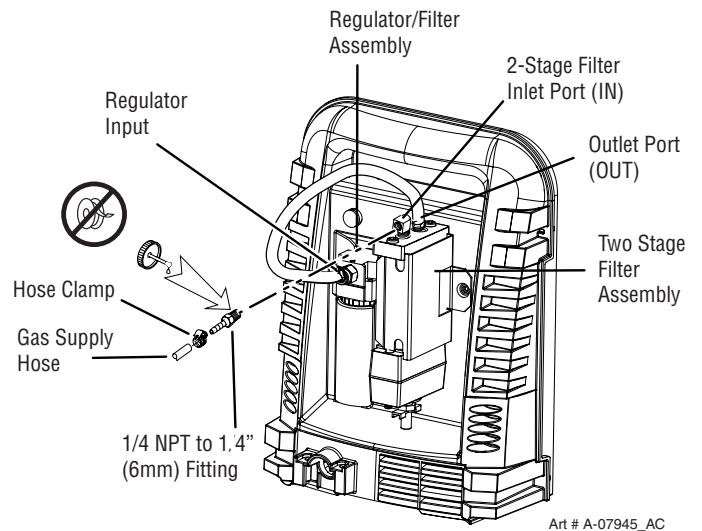

Optional Two - Stage Filter Installation

CUTMASTER 20mm

Using High Pressure Air Cylinders

When using high pressure air cylinders as the air supply:

1. Refer to the manufacturer's specifications for installation and maintenance procedures for high pressure regulators.
2. Examine the cylinder valves to be sure they are clean and free of oil, grease or any foreign material. Briefly open each cylinder valve to blow out any dust which may be present.
3. The cylinder must be equipped with an adjustable high - pressure regulator capable of outlet pressures up to 100 psi (6.9 bar) maximum and flows of at least 300 scfh (141.5 lpm).
4. Connect supply hose to the cylinder.

NOTE

Pressure should be set at 100 psi (6.9 bar) at the high pressure cylinder regulator.

Supply hose must be at least 1/4 inch (6 mm) I.D.

For a secure seal, apply thread sealant to the fitting threads, according to manufacturer's instructions. Do Not use Teflon tape as a thread sealer, as small particles of the tape may break off and block the small air passages in the torch.

SECTION 3 TORCH: INSTALLATION

3T.01 Torch Connections

If necessary, connect the torch to the Power Supply. Connect only the Thermal Dynamics model SL60 / Manual or SL100 / Mechanical Torch to this power supply. Maximum torch leads length is 100 feet / 30.5 m, including extensions.



WARNING

Disconnect primary power at the source before connecting the torch.

1. Align the ATC male connector (on the torch lead) with the female receptacle. Push the male connector into the female receptacle. The connectors should push together with a small amount of pressure.
2. Secure the connection by turning the locking nut clockwise until it clicks. **DO NOT** use the locking nut to pull the connection together. Do not use tools to secure the connection.

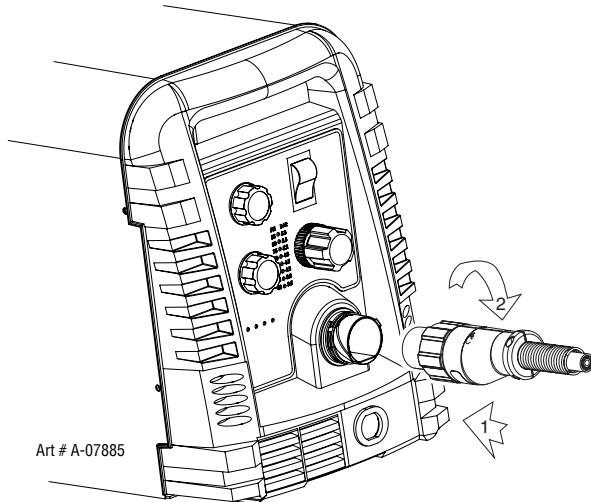

Connecting the Torch to the Power Supply

3. The system is ready for operation.

Check Air Quality

To test the quality of air:

1. Put the ON / OFF switch in the ON (up) position.
2. Put the Function Control switch in the SET position.
3. Place a welding filter lens in front of the torch and turn ON the air. **Do not start an arc!**

Any oil or moisture in the air will be visible on the lens.

3T.02 Setting Up Mechanical Torch

NOTE

An adapter is required to be installed in the power supply if converting a hand torch system to operate a machine torch.



WARNING

Disconnect primary power at the source before disassembling the torch or torch leads.

The mechanical torch includes a positioning tube with rack and pinch block assembly.

1. Mount the torch assembly on the cutting table.
2. To obtain a clean vertical cut, use a square to align the torch perpendicular to the surface of the workpiece.

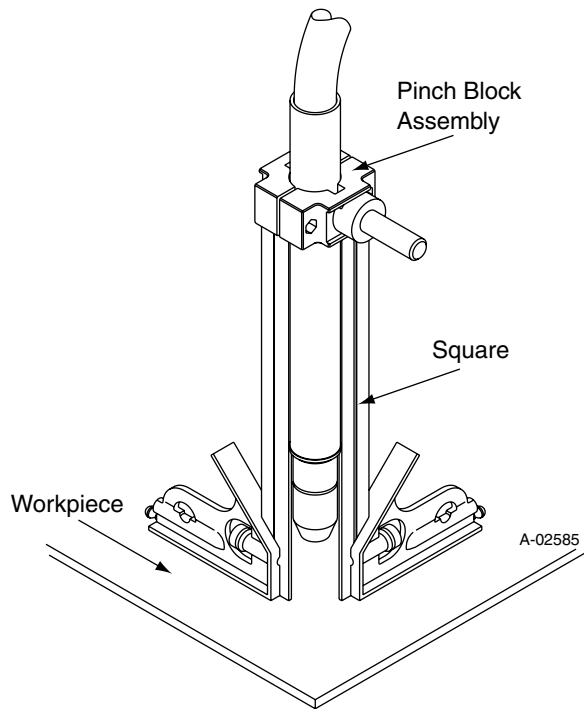

Mechanical Torch Set - Up

3. The proper torch parts (shield cup, tip, start cartridge, and electrode) must be installed for the type of operation. Refer to Section 4T.07, Torch Parts Selection for details.

SECTION 4 SYSTEM: OPERATION

4.01 Front Panel Controls / Features

See Illustration for numbering Identification

1. Output Current Control

Sets the desired output current. Output settings up to 60 Amps may be used for drag cutting (with the torch tip contacting the workpiece) or standoff cutting.



2. Function Control

Function Control Knob, Used to select between the different operating modes.

SET  Used to purge the air through the unit and torch and leads and to adjust gas pressure.

RUN  Used for general cutting operations

RAPID AUTO RESTART  Allows for faster restarting of the Pilot Arc for uninterrupted cutting.

LATCH   Used for longer hand held cuts. Once a cutting arc is established, the torch switch can be released. The cutting arc will remain ON until the torch is lifted away from the work piece, the torch leaves the edge of the work piece the torch switch is activated again or if one of the system interlocks is activated.

3. ON OFF Power Switch

ON  / **OFF**  Switch controls input power to the power supply. Up is ON, down is OFF.

4. Air/Gas Pressure Control

The Pressure  Control is used in the "SET" mode to adjust the air/gas pressure. Pull the knob out to adjust and push in to lock.

5. AC Indicator

Steady light indicates power supply is ready for operation. Blinking light indicates unit is in protective interlock mode. Shut unit OFF, shut OFF or disconnect input power, correct the fault, and restart the unit. Refer to Section 5 for details.

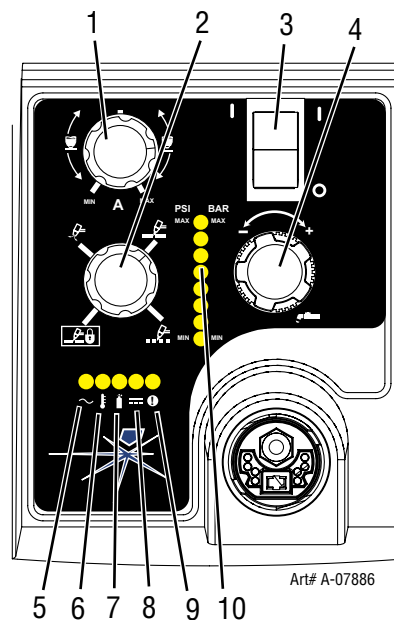

6. Temp Indicator

Indicator is normally OFF. Indicator is ON when internal temperature exceeds normal limits. Let the unit cool before continuing operation.

7. Gas Indicator

Indicator is ON when minimum input gas pressure for power supply operation is present. Minimum pressure for power supply operation is not sufficient for torch operation.

8. DC Indicator

Indicator is ON when DC output circuit is active.

9. Fault Error Indicator

Indicator is ON when Fault circuit is active. See section 5 for explanations of fault lights.

10. Pressure Indicators

| PSI | BAR |
|-----|-----|
| MAX | MAX |
| 90 | 6.3 |
| 85 | 5.9 |
| 80 | 5.5 |
| 75 | 5.2 |
| 70 | 4.8 |
| 65 | 4.5 |
| MIN | MIN |

Art # A-08170

The Indicators will illuminate according to the pressure set by the Pressure Control Knob (number 4).

4.02 Preparations for Operation

At the start of each operating session:



Disconnect primary power at the source before assembling or disassembling power supply, torch parts, or torch and leads assemblies.

Torch Parts Selection

Check the torch for proper assembly and appropriate torch parts. The torch parts must correspond with the type of operation, and with the amperage output of this Power Supply (60 amps maximum). Refer to Section 4T.07 and following for torch parts selection.

Torch Connection

Check that the torch is properly connected. Only Thermal Dynamics model SL60 / Manual or SL100 / Mechanical Torches may be connected to this Power Supply. See Section 3T of this manual.

Check Primary Input Power Source

1. Check the power source for proper input voltage. Make sure the input power source meets the power requirements for the unit per Section 2, Specifications.
2. Connect the input power cable (or close the main disconnect switch) to supply power to the system.

Air Source

Ensure source meets requirements (refer to Section 2). Check connections and turn air supply ON.

Connect Work Cable

Clamp the work cable to the workpiece or cutting table. The area must be free from oil, paint and rust. Connect only to the main part of the workpiece; do not connect to the part to be cut off.

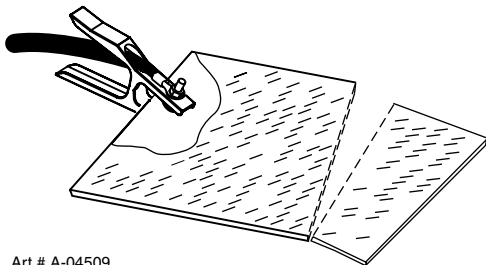

Art # A-04509

Power ON

Place the Power Supply ON / OFF switch to the ON (up) position. AC indicator  turns ON.

Gas indicator  turns ON if there is sufficient gas pressure for power supply operation and the cooling fans turn ON.

NOTE

Minimum pressure for power supply operation is lower than minimum for torch operation.

The cooling fans will turn ON as soon as the unit is turned ON. After the unit is idle for ten (10) minutes the fans will turn OFF. The fans will come back ON as soon as the torch switch (Start Signal) is activated or if the unit is turned OFF, then turned ON again. If an over temperature condition occurs, the fans will continue to run while the condition exists and for a ten (10) minute period once the condition is cleared.

Set Operating Pressure

1. Place the Power Supply Function Control knob to the SET  position. Gas will flow.
2. For Standoff cutting, adjust gas pressure from 70 - 85 psi / 4.8 - 5.9 bar (LED's in center of control panel). Refer to the Standoff chart for pressure setting details.

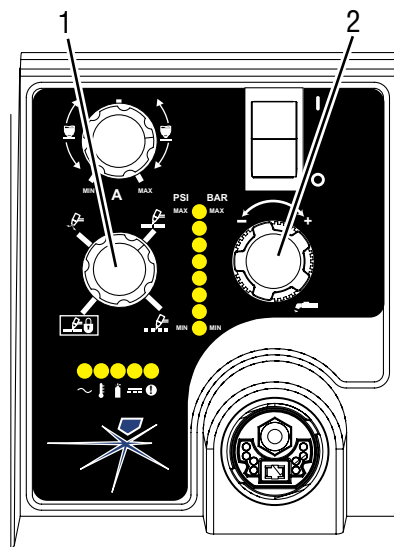

Art# A-07946

| STANDOFF | | |
|--------------------------------------|----------------------|--------------------------|
| CutMaster 20mm Gas Pressure Settings | | |
| Leads Length | SL60 (Hand Torch) | SL100 (Mechanized Torch) |
| Up to 25' (7.6 m) | 75 psi 5.2 bar | 75 psi 5.2 bar |
| Each additional 25' (7.6 m) | Add 5 psi 0.4 bar | Add 5 psi 0.4 bar |

- For Drag cutting, adjust gas pressure from 75 - 95 psi / 5.2 - 6.5 bar (LED's in center of control panel). Refer to the Drag Cutting chart for pressure setting details.

| DRAG | |
|--------------------------------------|----------------------|
| CutMaster 20mm Gas Pressure Settings | |
| Leads Length | SL60 (Hand Torch) |
| Up to 25' (7.6 m) | 80 psi 5.5 bar |
| Each additional 25' (7.6 m) | Add 5 psi 0.4 bar |

Select Current Output Level

- Place the Function Control Knob in one of the three operating positions available:

RUN 

RAPID AUTO RESTART 

or LATCH . Gas flow stops.

- Set the output current to desired amperage with the Output Current Control Knob.

Cutting Operation

When the torch leaves the workpiece during cutting operations with the Function Control Knob in the RUN position, there is a brief delay in restarting the pilot arc. With the knob in the **RAPID AUTO RESTART** position, when the torch leaves the workpiece the pilot arc restarts instantly, and the cutting arc restarts instantly when the pilot arc contacts the workpiece. (Use the 'Rapid Auto Restart' position when cutting expanded metal or gratings, or in gouging or trimming operations when an uninterrupted restart is desired). And with the knob in the LATCH position the main cutting arc will be maintained after the torch switch is released.

Typical Cutting Speeds



Cutting speeds vary according to torch output amperage, the type of material being cut, and operator skill. Refer to Section 4T.08 and following for greater details.

Output current setting or cutting speeds may be reduced to allow slower cutting when following a line, or using a template or cutting guide while still producing cuts of excellent quality.

Postflow

Release the trigger to stop the cutting arc. Gas continues to flow for approximately 20 seconds. During post-flow, if the user moves the trigger release to the rear and presses the trigger, the pilot arc starts. The main arc transfers to the workpiece if the torch tip is within transfer distance to the workpiece.

Shutdown

Turn the ON  / OFF  switch to OFF  (down). All Power Supply indicators shut OFF. Unplug the input power cord or disconnect input power. Power is removed from the system.

This Page Intentionally Blank

SECTION 4 TORCH: OPERATION

4T.01 Torch Parts Selection

Depending on the type of operation to be done determines the torch parts to be used.

Type of operation:

Drag cutting, standoff cutting or gouging

Torch parts:

Shield Cup, Cutting Tip, Electrode and Starter Cartridge

NOTE

Refer to Section 4T.07 and following for additional information on torch parts.

Change the torch parts for a different operation as follows:



WARNING

Disconnect primary power at the source before assembling or disassembling torch parts, or torch and leads assemblies.

NOTE

The shield cup holds the tip and starter cartridge in place. Position the torch with the shield cup facing upward to keep these parts from falling out when the cup is removed.

1. Unscrew and remove the shield cup assembly from the torch head.

2. Remove the Electrode by pulling it straight out of the Torch Head.

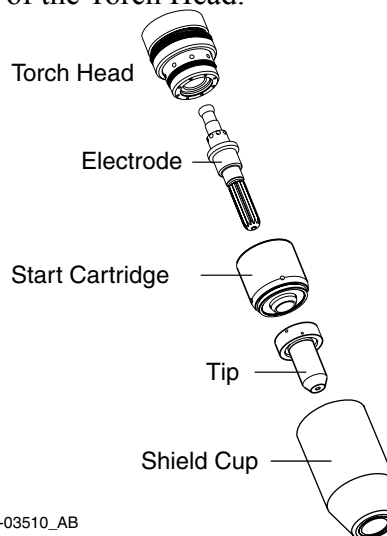

Torch Parts (Drag Shield Cap & Shield Cup Body Shown)

3. Install the replacement Electrode by pushing it straight into the torch head until it clicks.
4. Install the starter cartridge and desired tip for the operation into the torch head.
5. Hand tighten the shield cup assembly until it is seated on the torch head. If resistance is felt when installing the cup, check the threads before proceeding.

4T.02 Cut Quality

NOTE

Cut quality depends heavily on setup and parameters such as torch standoff, alignment with the workpiece, cutting speed, gas pressures, and operator ability.

Cut quality requirements differ depending on application. For instance, nitride build - up and bevel angle may be major factors when the surface will be welded after cutting. Dross - free cutting is important when finish cut quality is desired to avoid a secondary cleaning operation. The following cut quality characteristics are illustrated in the following figure:

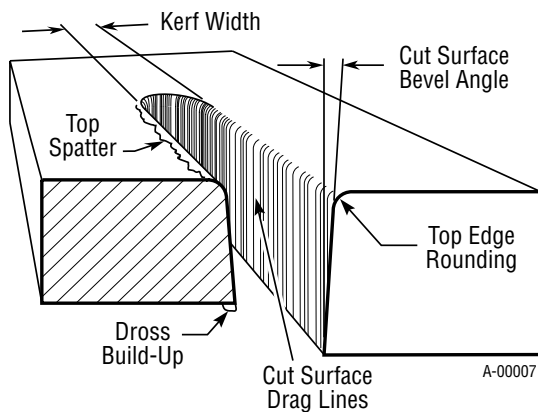

Cut Quality Characteristics

Cut Surface

The desired or specified condition (smooth or rough) of the face of the cut.

Nitride Build - Up

Nitride deposits can be left on the surface of the cut when nitrogen is present in the plasma gas stream. These buildups may create difficulties if the material is to be welded after the cutting process.

Bevel Angle

The angle between the surface of the cut edge and a plane perpendicular to the surface of the plate. A perfectly perpendicular cut would result in a 0° bevel angle.

Top - Edge Rounding

Rounding on the top edge of a cut due to wearing from the initial contact of the plasma arc on the workpiece.

Bottom Dross Buildup

Molten material which is not blown out of the cut area and resolidifies on the plate. Excessive dross may require secondary cleanup operations after cutting.

Kerf Width

The width of the cut (or the width of material removed during the cut).

Top Spatter (Dross)

Top spatter or dross on the top of the cut caused by slow travel speed, excess cutting height, or cutting tip whose orifice has become elongated.

4T.03 General Cutting Information



WARNING

Disconnect primary power at the source before disassembling the power supply, torch, or torch leads.

Frequently review the Important Safety Precautions at the front of this manual. Be sure the operator is equipped with proper gloves, clothing, eye and ear protection. Make sure no part of the operator's body comes into contact with the workpiece while the torch is activated.



CAUTION

Sparks from the cutting process can cause damage to coated, painted, and other surfaces such as glass, plastic and metal.

NOTE

Handle torch leads with care and protect them from damage.

Piloting

Piloting is harder on parts life than actual cutting because the pilot arc is directed from the electrode to the tip rather than to a workpiece. Whenever possible, avoid excessive pilot arc time to improve parts life.

Torch Standoff

Improper standoff (the distance between the torch tip and workpiece) can adversely affect tip life as well as shield cup life. Standoff may also significantly affect the bevel angle. Reducing standoff will generally result in a more square cut.

Edge Starting

For edge starts, hold the torch perpendicular to the workpiece with the front of the tip near (not touching) the edge of the workpiece at the point where the cut is to start. When starting at the edge of the plate, do not pause at the edge and force the arc to "reach" for the edge of the metal. Establish the cutting arc as quickly as possible.

Direction of Cut

In the torches, the plasma gas stream swirls as it leaves the torch to maintain a smooth column of gas. This swirl effect results in one side of a cut being more square than the other. Viewed along the direction of travel, the right side of the cut is more square than the left.

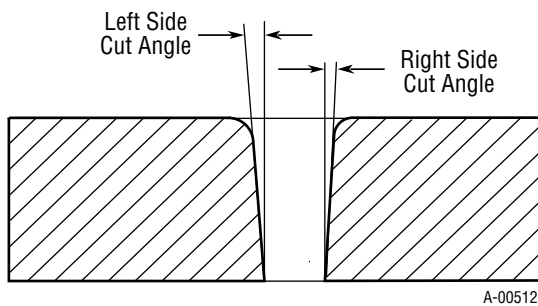

Side Characteristics Of Cut

To make a square - edged cut along an inside diameter of a circle, the torch should move counterclockwise around the circle. To keep the square edge along an outside diameter cut, the torch should travel in a clockwise direction.

Dross

When dross is present on carbon steel, it is commonly referred to as either "high speed, slow speed, or top dross". Dross present on top of the plate is normally caused by too great a torch to plate distance. "Top dross" is normally very easy to remove and can often be wiped off with a welding glove. "Slow speed dross" is normally present on the bottom edge of the plate. It can vary from a light to heavy bead, but does not adhere tightly to the cut edge, and can be easily scraped off. "High speed dross" usually forms a narrow bead along the bottom of the cut edge and is very difficult to remove. When cutting a troublesome steel, it is sometimes useful to reduce the cutting speed to produce "slow speed dross". Any resultant cleanup can be accomplished by scraping, not grinding.

4T.04 Hand Torch Operation

Standoff Cutting With Hand Torch

NOTE

For best performance and parts life, always use the correct parts for the type of operation.

1. The torch can be comfortably held in one hand or steadied with two hands. Position the hand to press the Trigger on the torch handle. With the hand torch, the hand may be positioned close to the torch head for maximum control or near the back end for maximum heat protection. Choose the holding technique that feels most comfortable and allows good control and movement.

NOTE

The tip should never come in contact with the workpiece except during drag cutting operations.

2. Depending on the cutting operation, do one of the following:
 - a. For **edge starts**, hold the torch perpendicular to the workpiece with the front of the tip on the edge of the workpiece at the point where the cut is to start.
 - b. For **standoff cutting**, hold the torch 1/8 - 3/8 in (3-9 mm) from the workpiece as shown below.

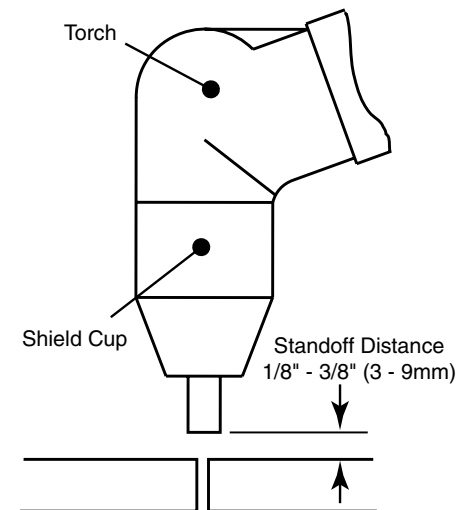

Standoff Distance

3. Hold the torch away from your body.
4. Slide the trigger release toward the back of the torch handle while simultaneously squeezing the trigger. The pilot arc will start.

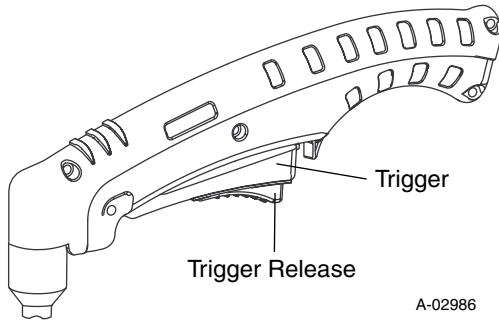

A-02986

5. Bring the torch within transfer distance to the work. The main arc will transfer to the work, and the pilot arc will shut OFF.

NOTE

The gas preflow and postflow are a characteristic of the power supply and not a function of the torch.

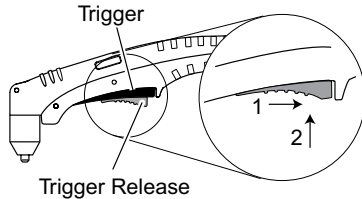

Trigger Release

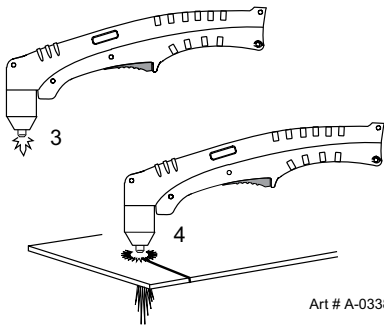

Art # A-03383

6. Cut as usual. Simply release the trigger assembly to stop cutting.
7. Follow normal recommended cutting practices as provided in the power supply operator's manual.

NOTE

When the shield cup is properly installed, there is a slight gap between the shield cup and the torch handle. Gas vents through this gap as part of normal operation. Do not attempt to force the shield cup to close this gap. Forcing the shield cup against the torch head or torch handle can damage components.

8. For a consistent standoff height from the workpiece, install the standoff guide by sliding it onto the torch shield cup. Install the guide with the legs at the sides of the shield cup body to maintain good visibility of the cutting arc. During operation, position the legs of the standoff guide against the workpiece.

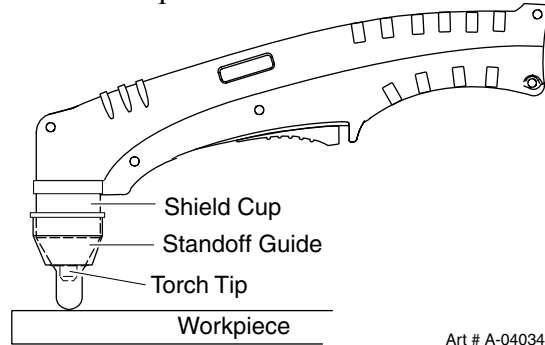

Art # A-04034

Shield Cup With Straight Edge

The drag shield cup can be used with a non conductive straight edge to make straight cuts by hand.



WARNING

*The straight edge **must be** non - conductive.*

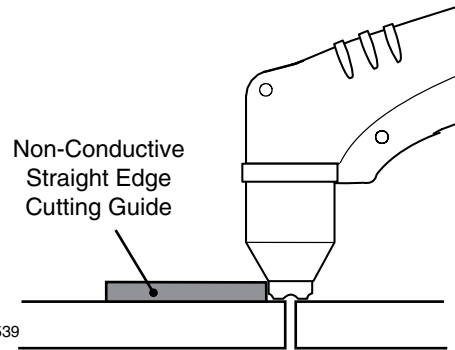

A-03539

Using Drag Shield Cup With Straight Edge

The crown shield cup functions best when cutting 3/16 inch (4.7 mm) solid metal with relatively smooth surface.

Drag Cutting With a Hand Torch

Drag cutting works best on metal 1/4" (6 mm) thick or less.

NOTE

For best parts performance and life, always use the correct parts for the type of operation.

1. Install the drag cutting tip and set the output current.
2. The torch can be comfortably held in one hand or steadied with two hands. Position the hand to press the Trigger on the torch handle. With the hand torch, the hand may be positioned close to the torch head for maximum control or near the back end for maximum heat protection. Choose the holding technique that feels most comfortable and allows good control and movement.
4. Keep the torch in contact with the workpiece during the cutting cycle.
5. Hold the torch away from your body.
6. Slide the trigger release toward the back of the torch handle while simultaneously squeezing the trigger. The pilot arc will start.

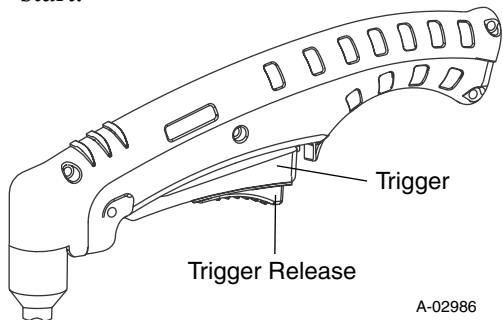

7. Bring the torch within transfer distance to the work. The main arc will transfer to the work, and the pilot arc will shut OFF.

NOTE

The gas preflow and postflow are a characteristic of the power supply and not a function of the torch.

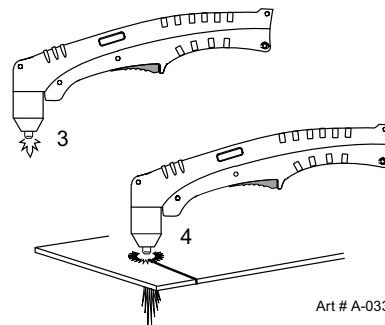
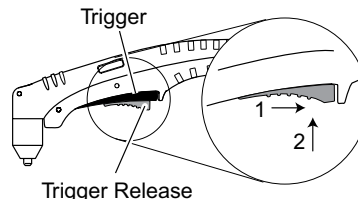

8. Cut as usual. Simply release the trigger assembly to stop cutting.
9. Follow normal recommended cutting practices as provided in the power supply operator's manual.

NOTE

When the shield cup is properly installed, there is a slight gap between the shield cup and the torch handle. Gas vents through this gap as part of normal operation. Do not attempt to force the shield cup to close this gap. Forcing the shield cup against the torch head or torch handle can damage components.

Piercing With Hand Torch

1. The torch can be comfortably held in one hand or steadied with two hands. Position the hand to press the Trigger on the torch handle. With the hand torch, the hand may be positioned close to the torch head for maximum control or near the back end for maximum heat protection. Choose the technique that feels most comfortable and allows good control and movement.

NOTE

The tip should never come in contact with the workpiece except during drag cutting operations.

2. Angle the torch slightly to direct blowback particles away from the torch tip (and operator) rather than directly back into it until the pierce is complete.

3. In a portion of the unwanted metal start the pierce off the cutting line and then continue the cut onto the line. Hold the torch perpendicular to the workpiece after the pierce is complete.
4. Hold the torch away from your body.
5. Slide the trigger release toward the back of the torch handle while simultaneously squeezing the trigger. The pilot arc will start.

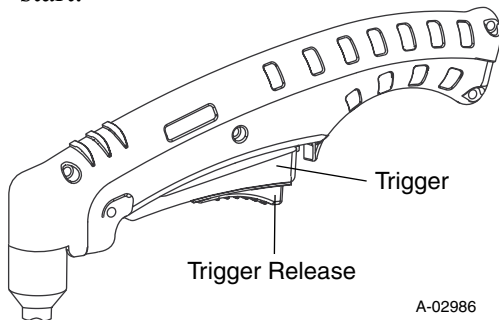

6. Bring the torch within transfer distance to the work. The main arc will transfer to the work, and the pilot arc will shut OFF.

NOTE

The gas preflow and postflow are a characteristic of the power supply and not a function of the torch.

When the shield cup is properly installed, there is a slight gap between the shield cup and the torch handle. Gas vents through this gap as part of normal operation. Do not attempt to force the shield cup to close this gap. Forcing the shield cup against the torch head or torch handle can damage components.

7. Clean spatter and scale from the shield cup and the tip as soon as possible. Spraying the shield cup in anti - spatter compound will minimize the amount of scale which adheres to it.

Cutting speed depends on material, thickness, and the operator's ability to accurately follow the desired cut line. The following factors may have an impact on system performance:

- Torch parts wear
- Air quality
- Line voltage fluctuations
- Torch standoff height
- Proper work cable connection

4T.05Gouging



WARNING

Be sure the operator is equipped with proper gloves, clothing, eye and ear protection and that all safety precautions at the front of this manual have been followed. Make sure no part of the operator's body comes in contact with the workpiece when the torch is activated.

Disconnect primary power to the system before disassembling the torch, leads, or power supply.



CAUTION

Sparks from plasma gouging can cause damage to coated, painted or other surfaces such as glass, plastic, and metal.

Check torch parts. The torch parts must correspond with the type of operation. Refer to Section 4T.07, Torch Parts Selection.

Gouging Parameters

Gouging performance depends on parameters such as torch travel speed, current level, lead angle (the angle between the torch and workpiece), and the distance between the torch tip and workpiece (standoff).



CAUTION

Touching the torch tip or shield cup to the work surface will cause excessive parts wear.

Torch Travel Speed

NOTE

Refer to Appendix Pages for additional information as related to the Power Supply used.

Optimum torch travel speed is dependent on current setting, lead angle, and mode of operation (hand or machine torch).

Current Setting

Current settings depend on torch travel speed, mode of operation (hand or machine torch), and the amount of material to be removed.

Lead Angle

The angle between the torch and workpiece depends on the output current setting and torch travel speed. The recommended lead angle is 35°. At a lead angle greater than 45° the molten metal will not be blown out of the gouge and may be blown back onto the torch. If the lead angle is too small (less than 35°), less material may be removed, requiring more passes. In some applications, such as removing welds or working with light metal, this may be desirable.

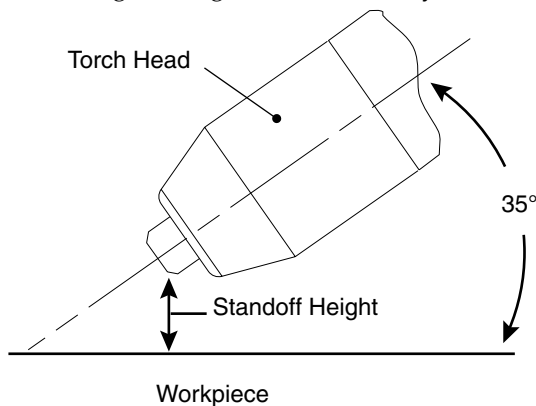

A-00941_AB

Gouging Angle and Standoff Distance

Standoff Distance

The tip to work distance affects gouge quality and depth. Standoff distance of 1/8 - 1/4 inch (3 - 6 mm) allows for smooth, consistent metal removal. Smaller standoff distances may result in a severance cut rather than a gouge. Standoff distances greater than 1/4 inch (6 mm) may result in minimal metal removal or loss of transferred main arc.

Slag Buildup

Slag generated by gouging on materials such as carbon and stainless steels, nickels, and alloyed steels, can be removed easily in most cases. Slag does not obstruct the gouging process if it accumulates to the side of the gouge path. However, slag build - up can cause inconsistencies and irregular metal removal if large amounts of material build up in front of the arc. The build - up is most often a result of improper travel speed, lead angle, or standoff height.

4T.06Mechanized Torch Operation

Cutting With Mechanized Torch

The mechanized torch can be activated by remote control pendant or by a remote interface device such as CNC.

1. To start a cut at the plate edge, position the center of the torch along the edge of the plate.

Travel Speed

Proper travel speed is indicated by the trail of the arc which is seen below the plate. The arc can be one of the following:

1. Straight Arc

A straight arc is perpendicular to the workpiece surface. This arc is generally recommended for the best cut using air plasma on stainless or aluminum.

2. Leading Arc

The leading arc is directed in the same direction as torch travel. A five degree leading arc is generally recommended for air plasma on mild steel.

3. Trailing Arc

The trailing arc is directed in the opposite direction as torch travel.

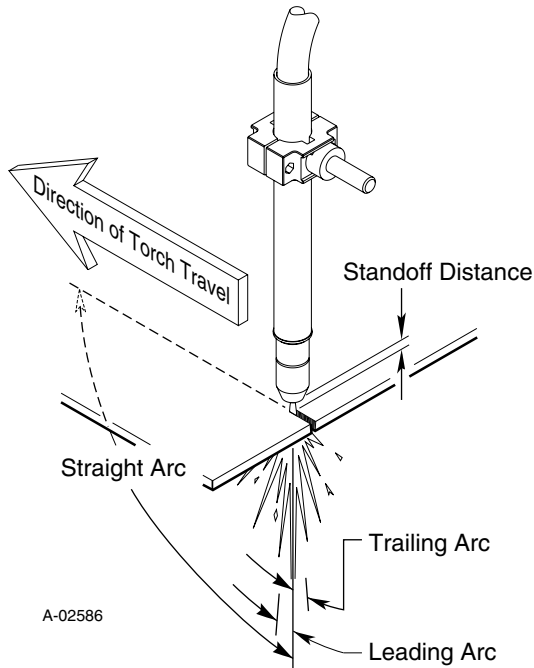

Mechanized Torch Operation

For optimum smooth surface quality, the travel speed should be adjusted so that only the leading edge of the arc column produces the cut. If the travel speed is too slow, a rough cut will be produced as the arc moves from side to side in search of metal for transfer.

Travel speed also affects the bevel angle of a cut. When cutting in a circle or around a corner, slowing down the travel speed will result in a squarer cut. The power source output should be reduced also. Refer to the appropriate Control Module Operating Manual for any Corner Slowdown adjustments that may be required.

Piercing With Machine Torch

To pierce with a machine torch, the arc should be started with the torch positioned as high as possible above the plate while allowing the arc to transfer and pierce. This standoff helps avoid having molten metal blow back onto the front end of the torch.

When operating with a cutting machine, a pierce or dwell time is required. Torch travel should not be enabled until the arc penetrates the bottom of the plate. As motion begins, torch standoff should be reduced to the recommended 1/8 - 1/4 inch (3-6 mm) distance for optimum speed and cut quality. Clean spatter and scale from the shield cup and the tip as soon as possible. Spraying or dipping the shield cup in anti-spatter compound will minimize the amount of scale which adheres to it.

4T.07 Parts Selection for SL60 Torch Cutting

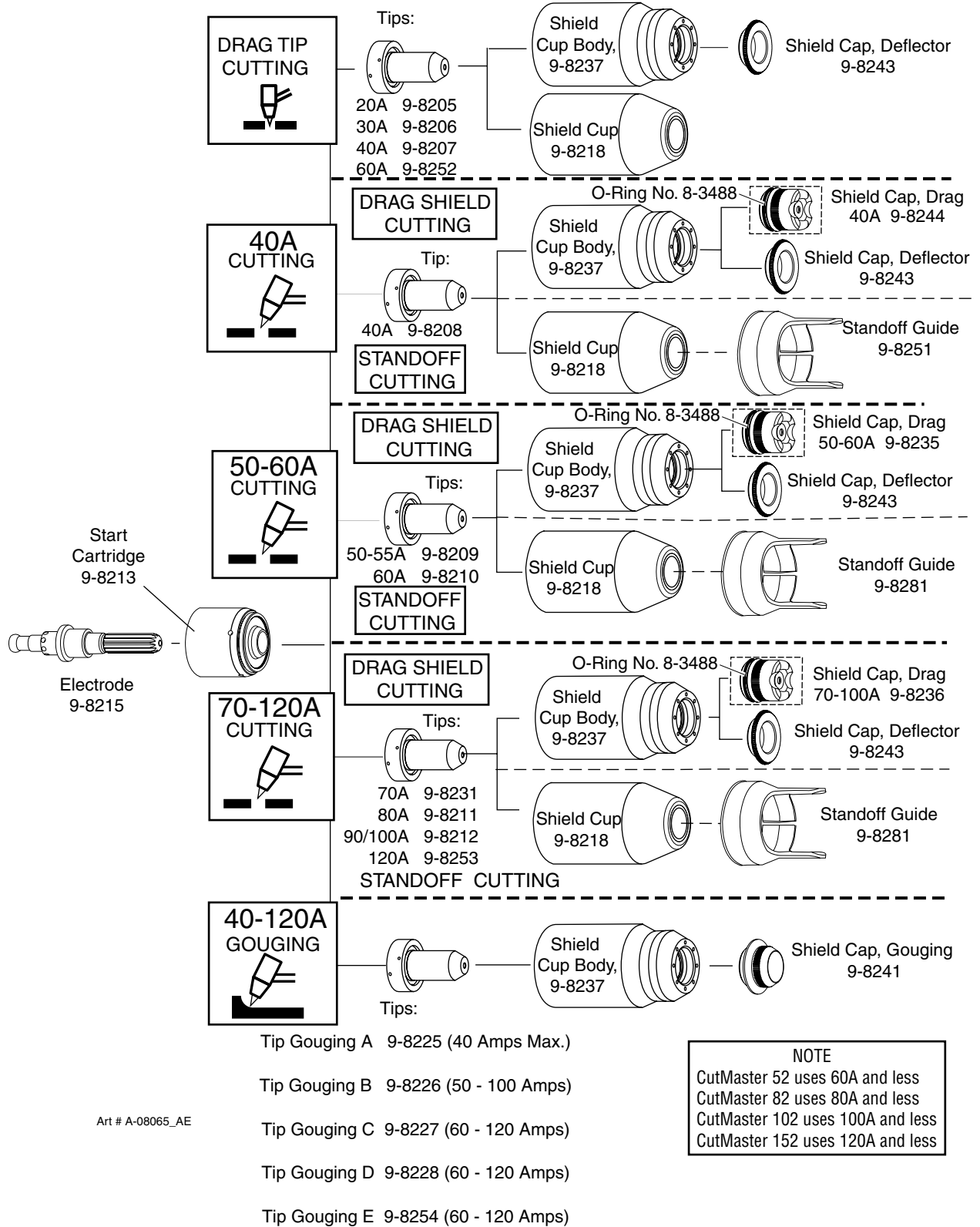

CUTMASTER 20mm

4T.08 Recommended Cutting Speeds for SL60 Torch With Exposed Tip

| Type Torch: SL60 With Exposed Tip | | | | | | | Type Material: Mild Steel | | | | | | | | |
|-----------------------------------|------|------------|------------|----------|--------------------|--------|--------------------------------------|-----|------------------|-----|------------|---------|-------------|---------------|-----|
| Type Plasma Gas: Air | | | | | | | Type Secondary Gas: Single Gas Torch | | | | | | | | |
| Thickness | | Tip | Output | Amperage | Speed (Per Minute) | | Standoff | | Plasma Gas Press | | Flow (CFH) | | Pierce | Pierce Height | |
| Inches | mm | (Cat. No.) | Volts(VDC) | (Amps) | Inches | Meters | Inches | mm | psi* | bar | Plasma | Total** | Delay (Sec) | Inches | mm |
| 0.036 | 0.9 | 9-8208 | 104 | 40 | 340 | 8.64 | 0.19 | 4.8 | 70 | 4.8 | 55 | 170 | 0.00 | 0.2 | 5.1 |
| 0.06 | 1.5 | 9-8208 | 108 | 40 | 250 | 6.35 | 0.19 | 4.8 | 70 | 4.8 | 55 | 170 | 0.10 | 0.2 | 5.1 |
| 0.075 | 1.9 | 9-8208 | 108 | 40 | 190 | 4.83 | 0.19 | 4.8 | 70 | 4.8 | 55 | 170 | 0.30 | 0.2 | 5.1 |
| 0.135 | 3.4 | 9-8208 | 110 | 40 | 105 | 2.67 | 0.19 | 4.8 | 70 | 4.8 | 55 | 170 | 0.40 | 0.2 | 5.1 |
| 0.188 | 4.8 | 9-8208 | 113 | 40 | 60 | 1.52 | 0.19 | 4.8 | 70 | 4.8 | 55 | 170 | 0.60 | 0.2 | 5.1 |
| 0.25 | 6.4 | 9-8208 | 111 | 40 | 40 | 1.02 | 0.19 | 4.8 | 70 | 4.8 | 55 | 170 | 1.00 | 0.2 | 5.1 |
| 0.375 | 9.5 | 9-8208 | 124 | 40 | 21 | 0.53 | 0.19 | 4.8 | 70 | 4.8 | 55 | 170 | NR | NR | NR |
| 0.500 | 12.7 | 9-8208 | 123 | 40 | 11 | 0.28 | 0.19 | 4.8 | 70 | 4.8 | 55 | 170 | NR | NR | NR |
| 0.625 | 15.9 | 9-8208 | 137 | 40 | 7 | 0.18 | 0.19 | 4.8 | 70 | 4.8 | 55 | 170 | NR | NR | NR |

| Type Torch: SL60 With Exposed Tip | | | | | | | Type Material: Stainless Steel | | | | | | | | |
|-----------------------------------|-----|------------|------------|----------|--------------------|--------|--------------------------------------|-----|------------------|-----|------------|---------|-------------|---------------|-----|
| Type Plasma Gas: Air | | | | | | | Type Secondary Gas: Single Gas Torch | | | | | | | | |
| Thickness | | Tip | Output | Amperage | Speed (Per Minute) | | Standoff | | Plasma Gas Press | | Flow (CFH) | | Pierce | Pierce Height | |
| Inches | mm | (Cat. No.) | Volts(VDC) | (Amps) | Inches | Meters | Inches | mm | psi* | bar | Plasma | Total** | Delay (Sec) | Inches | mm |
| 0.036 | 0.9 | 9-8208 | 103 | 40 | 355 | 9.02 | 0.125 | 3.2 | 70 | 4.8 | 55 | 170 | 0.00 | 0.2 | 5.1 |
| 0.05 | 1.3 | 9-8208 | 98 | 40 | 310 | 7.87 | 0.125 | 3.2 | 70 | 4.8 | 55 | 170 | 0.00 | 0.2 | 5.1 |
| 0.06 | 1.5 | 9-8208 | 98 | 40 | 240 | 6.10 | 0.125 | 3.2 | 70 | 4.8 | 55 | 170 | 0.10 | 0.2 | 5.1 |
| 0.078 | 2.0 | 9-8208 | 100 | 40 | 125 | 3.18 | 0.125 | 3.2 | 70 | 4.8 | 55 | 170 | 0.30 | 0.2 | 5.1 |
| 0.135 | 3.4 | 9-8208 | 120 | 40 | 30 | 0.76 | 0.187 | 4.8 | 70 | 4.8 | 55 | 170 | 0.40 | 0.2 | 5.1 |
| 0.188 | 4.8 | 9-8208 | 124 | 40 | 20 | 0.51 | 0.187 | 4.8 | 70 | 4.8 | 55 | 170 | 0.60 | 0.2 | 5.1 |
| 0.25 | 6.4 | 9-8208 | 122 | 40 | 15 | 0.38 | 0.187 | 4.8 | 70 | 4.8 | 55 | 170 | 1.00 | 0.2 | 5.1 |
| 0.375 | 9.5 | 9-8208 | 126 | 40 | 10 | 0.25 | 0.187 | 4.8 | 70 | 4.8 | 55 | 170 | NR | NR | NR |

| Type Torch: SL60 With Exposed Tip | | | | | | | Type Material: Aluminum | | | | | | | | |
|-----------------------------------|-----|------------|------------|----------|--------------------|--------|--------------------------------------|-----|------------------|-----|------------|---------|-------------|---------------|-----|
| Type Plasma Gas: Air | | | | | | | Type Secondary Gas: Single Gas Torch | | | | | | | | |
| Thickness | | Tip | Output | Amperage | Speed (Per Minute) | | Standoff | | Plasma Gas Press | | Flow (CFH) | | Pierce | Pierce Height | |
| Inches | mm | (Cat. No.) | Volts(VDC) | (Amps) | Inches | Meters | Inches | mm | psi* | bar | Plasma | Total** | Delay (Sec) | Inches | mm |
| 0.032 | 0.8 | 9-8208 | 110 | 40 | 440 | 11.18 | 0.187 | 4.8 | 70 | 4.8 | 55 | 170 | 0.00 | 0.2 | 5.1 |
| 0.051 | 1.3 | 9-8208 | 109 | 40 | 350 | 8.89 | 0.187 | 4.8 | 70 | 4.8 | 55 | 170 | 0.10 | 0.2 | 5.1 |
| 0.064 | 1.6 | 9-8208 | 112 | 40 | 250 | 6.35 | 0.187 | 4.8 | 70 | 4.8 | 55 | 170 | 0.10 | 0.2 | 5.1 |
| 0.079 | 2.0 | 9-8208 | 112 | 40 | 200 | 5.08 | 0.19 | 4.8 | 70 | 4.8 | 55 | 170 | 0.30 | 0.2 | 5.1 |
| 0.125 | 3.2 | 9-8208 | 118 | 40 | 100 | 2.54 | 0.19 | 4.8 | 70 | 4.8 | 55 | 170 | 0.40 | 0.2 | 5.1 |
| 0.188 | 4.8 | 9-8208 | 120 | 40 | 98 | 2.49 | 0.187 | 4.8 | 70 | 4.8 | 55 | 170 | 0.60 | 0.2 | 5.1 |
| 0.250 | 6.4 | 9-8208 | 123 | 40 | 50 | 1.27 | 0.187 | 4.8 | 70 | 4.8 | 55 | 170 | 1.00 | 0.2 | 5.1 |
| 0.375 | 9.5 | 9-8208 | 134 | 40 | 16 | 0.41 | 0.187 | 4.8 | 70 | 4.8 | 55 | 170 | NR | NR | NR |

| Type Torch: SL60 With Exposed Tip | | | | | | | Type Material: Stainless Steel | | | | | | | | |
|-----------------------------------|------|------------|------------|----------|--------------------|--------|--------------------------------------|-----|------------------|-----|------------|---------|-------------|---------------|-----|
| Type Plasma Gas: Air | | | | | | | Type Secondary Gas: Single Gas Torch | | | | | | | | |
| Thickness | | Tip | Output | Amperage | Speed (Per Minute) | | Standoff | | Plasma Gas Press | | Flow (CFH) | | Pierce | Pierce Height | |
| Inches | mm | (Cat. No.) | Volts(VDC) | (Amps) | Inches | Meters | Inches | mm | psi* | bar | Plasma | Total** | Delay (Sec) | Inches | mm |
| 0.06 | 1.5 | 9-8210 | 119 | 60 | 350 | 8.91 | 0.19 | 4.8 | 75 | 5.2 | 90 | 245 | 0.00 | 0.20 | 5.1 |
| 0.075 | 1.9 | 9-8210 | 116 | 60 | 300 | 7.64 | 0.19 | 4.8 | 75 | 5.2 | 90 | 245 | 0.10 | 0.20 | 5.1 |
| 0.120 | 3.0 | 9-8210 | 123 | 60 | 150 | 3.82 | 0.19 | 4.8 | 75 | 5.2 | 90 | 245 | 0.10 | 0.20 | 5.1 |
| 0.135 | 3.4 | 9-8210 | 118 | 60 | 125 | 3.18 | 0.19 | 4.8 | 75 | 5.2 | 90 | 245 | 0.10 | 0.20 | 5.1 |
| 0.188 | 4.8 | 9-8210 | 122 | 60 | 90 | 2.29 | 0.19 | 4.8 | 75 | 5.2 | 90 | 245 | 0.20 | 0.20 | 5.1 |
| 0.250 | 6.4 | 9-8210 | 120 | 60 | 65 | 1.65 | 0.19 | 4.8 | 75 | 5.2 | 90 | 245 | 0.30 | 0.20 | 5.1 |
| 0.375 | 9.5 | 9-8210 | 130 | 60 | 30 | 0.76 | 0.19 | 4.8 | 75 | 5.2 | 90 | 245 | 0.50 | 0.20 | 5.1 |
| 0.500 | 12.7 | 9-8210 | 132 | 60 | 21 | 0.53 | 0.19 | 4.8 | 75 | 5.2 | 90 | 245 | 0.75 | 0.20 | 5.1 |
| 0.625 | 15.9 | 9-8210 | 130 | 60 | 15 | 0.38 | 0.19 | 4.8 | 75 | 5.2 | 90 | 245 | NR | NR | NR |
| 0.750 | 19.1 | 9-8210 | 142 | 60 | 12 | 0.31 | 0.25 | 6.4 | 75 | 5.2 | 90 | 245 | NR | NR | NR |

| Type Torch: SL60 With Exposed Tip | | | | | | | Type Material: Mild Steel | | | | | | | | |
|-----------------------------------|------|------------|------------|----------|--------------------|--------|--------------------------------------|-----|------------------|-----|------------|---------|-------------|---------------|-----|
| Type Plasma Gas: Air | | | | | | | Type Secondary Gas: Single Gas Torch | | | | | | | | |
| Thickness | | Tip | Output | Amperage | Speed (Per Minute) | | Standoff | | Plasma Gas Press | | Flow (CFH) | | Pierce | Pierce Height | |
| Inches | mm | (Cat. No.) | Volts(VDC) | (Amps) | Inches | Meters | Inches | mm | psi* | bar | Plasma | Total** | Delay (Sec) | Inches | mm |
| 0.060 | 1.5 | 9-8210 | 110 | 60 | 290 | 7.37 | 0.19 | 4.8 | 75 | 5.2 | 90 | 245 | 0.00 | 0.19 | 4.8 |
| 0.075 | 1.9 | 9-8210 | 120 | 60 | 285 | 7.24 | 0.19 | 4.8 | 75 | 5.2 | 90 | 245 | 0.10 | 0.19 | 4.8 |
| 0.120 | 3.0 | 9-8210 | 120 | 60 | 180 | 4.57 | 0.19 | 4.8 | 75 | 5.2 | 90 | 245 | 0.10 | 0.19 | 4.8 |
| 0.135 | 3.4 | 9-8210 | 119 | 60 | 170 | 4.32 | 0.19 | 4.8 | 75 | 5.2 | 90 | 245 | 0.10 | 0.19 | 4.8 |
| 0.188 | 4.8 | 9-8210 | 121 | 60 | 100 | 2.54 | 0.19 | 4.8 | 75 | 5.2 | 90 | 245 | 0.20 | 0.19 | 4.8 |
| 0.250 | 6.4 | 9-8210 | 119 | 60 | 80 | 2.03 | 0.19 | 4.8 | 75 | 5.2 | 90 | 245 | 0.30 | 0.19 | 4.8 |
| 0.375 | 9.5 | 9-8210 | 124 | 60 | 50 | 1.27 | 0.19 | 4.8 | 75 | 5.2 | 90 | 245 | 0.50 | 0.19 | 4.8 |
| 0.500 | 12.7 | 9-8210 | 126 | 60 | 26 | 0.66 | 0.19 | 4.8 | 75 | 5.2 | 90 | 245 | 0.75 | 0.19 | 4.8 |
| 0.625 | 15.9 | 9-8210 | 127 | 60 | 19 | 0.48 | 0.19 | 4.8 | 75 | 5.2 | 90 | 245 | NR | NR | NR |
| 0.750 | 19.1 | 9-8210 | 134 | 60 | 14 | 0.36 | 0.19 | 4.8 | 75 | 5.2 | 90 | 245 | NR | NR | NR |
| 1.000 | 25.4 | 9-8210 | 140 | 60 | 6 | 0.15 | 0.19 | 4.8 | 75 | 5.2 | 90 | 245 | NR | NR | NR |

CUTMASTER 20mm

| Type Torch: SL60 With Exposed Tip | | | | | | | Type Material: Aluminum | | | | | | | | |
|-----------------------------------|------|------------|------------|----------|--------------------|--------|--------------------------------------|-----|------------------|-----|------------|---------|-------------|---------------|-----|
| Type Plasma Gas: Air | | | | | | | Type Secondary Gas: Single Gas Torch | | | | | | | | |
| Thickness | | Tip | Output | Amperage | Speed (Per Minute) | | Standoff | | Plasma Gas Press | | Flow (CFH) | | Pierce | Pierce Height | |
| Inches | mm | (Cat. No.) | Volts(VDC) | (Amps) | Inches | Meters | Inches | mm | psi* | bar | Plasma | Total** | Delay (Sec) | Inches | mm |
| 0.060 | 1.5 | 9-8210 | 110 | 60 | 440 | 11.18 | 0.25 | 6.4 | 75 | 5.2 | 90 | 245 | 0.00 | 0.25 | 6.4 |
| 0.075 | 1.9 | 9-8210 | 110 | 60 | 440 | 11.18 | 0.25 | 6.4 | 75 | 5.2 | 90 | 245 | 0.10 | 0.25 | 6.4 |
| 0.120 | 3.0 | 9-8210 | 116 | 60 | 250 | 6.35 | 0.25 | 6.4 | 75 | 5.2 | 90 | 245 | 0.10 | 0.25 | 6.4 |
| 0.188 | 3.4 | 9-8210 | 116 | 60 | 170 | 4.32 | 0.25 | 6.4 | 75 | 5.2 | 90 | 245 | 0.20 | 0.25 | 6.4 |
| 0.250 | 6.4 | 9-8210 | 132 | 60 | 85 | 2.16 | 0.25 | 6.4 | 75 | 5.2 | 90 | 245 | 0.30 | 0.25 | 6.4 |
| 0.375 | 9.5 | 9-8210 | 140 | 60 | 45 | 1.14 | 0.25 | 6.4 | 75 | 5.2 | 90 | 245 | 0.50 | 0.25 | 6.4 |
| 0.500 | 12.7 | 9-8210 | 143 | 60 | 30 | 0.76 | 0.25 | 6.4 | 75 | 5.2 | 90 | 245 | 0.80 | 0.25 | 6.4 |
| 0.625 | 15.9 | 9-8210 | 145 | 60 | 20 | 0.51 | 0.25 | 6.4 | 75 | 5.2 | 90 | 245 | NR | NR | NR |
| 0.750 | 19.1 | 9-8210 | 145 | 60 | 18 | 0.46 | 0.25 | 6.4 | 75 | 5.2 | 90 | 245 | NR | NR | NR |

NOTE

* Gas pressure shown is for torches with leads up to 25' / 7.6 m long. For 50' / 15.2 m leads, refer to section 4.02 "Operating Pressure".

** Total flow rate includes plasma and secondary gas flow.

4T.09 Recommended Cutting Speeds for SL60 Torch With Shielded Tip

| Type Torch: SL60 With Shielded Tip | | | | | | | Type Material: Mild Steel | | | | | | | | |
|------------------------------------|------|------------|-------------|----------|--------------------|--------|--------------------------------------|-----|------------------|-----|------------|---------|-------------|---------------|-----|
| Type Plasma Gas: Air | | | | | | | Type Secondary Gas: Single Gas Torch | | | | | | | | |
| Thickness | | Tip | Output | Amperage | Speed (Per Minute) | | Standoff | | Plasma Gas Press | | Flow (CFH) | | Pierce | Pierce Height | |
| Inches | mm | (Cat. No.) | Volts (VDC) | (Amps) | Inches | Meters | Inches | mm | psi* | bar | Plasma | Total** | Delay (Sec) | Inches | mm |
| 0.036 | 0.9 | 9-8208 | 114 | 40 | 170 | 4.32 | 0.19 | 4.8 | 70 | 4.8 | 55 | 170 | 0.00 | 0.2 | 5.1 |
| 0.06 | 1.5 | 9-8208 | 120 | 40 | 90 | 2.29 | 0.19 | 4.8 | 70 | 4.8 | 55 | 170 | 0.10 | 0.2 | 5.1 |
| 0.075 | 1.9 | 9-8208 | 121 | 40 | 80 | 2.03 | 0.19 | 4.8 | 70 | 4.8 | 55 | 170 | 0.30 | 0.2 | 5.1 |
| 0.135 | 3.4 | 9-8208 | 122 | 40 | 75 | 1.91 | 0.19 | 4.8 | 70 | 4.8 | 55 | 170 | 0.40 | 0.2 | 5.1 |
| 0.188 | 4.8 | 9-8208 | 123 | 40 | 30 | 0.76 | 0.19 | 4.8 | 70 | 4.8 | 55 | 170 | 0.60 | 0.2 | 5.1 |
| 0.25 | 6.4 | 9-8208 | 125 | 40 | 25 | 0.64 | 0.19 | 4.8 | 70 | 4.8 | 55 | 170 | 1.00 | 0.2 | 5.1 |
| 0.375 | 9.5 | 9-8208 | 138 | 40 | 11 | 0.28 | 0.19 | 4.8 | 70 | 4.8 | 55 | 170 | NR | NR | NR |
| 0.500 | 12.7 | 9-8208 | 142 | 40 | 7 | 0.18 | 0.19 | 4.8 | 70 | 4.8 | 55 | 170 | NR | NR | NR |
| 0.625 | 15.9 | 9-8208 | 152 | 40 | 3 | 0.08 | 0.19 | 4.8 | 70 | 4.8 | 55 | 170 | NR | NR | NR |

| Type Torch: SL60 With Shielded Tip | | | | | | | Type Material: Stainless Steel | | | | | | | | |
|------------------------------------|-----|------------|------------|----------|--------------------|--------|--------------------------------------|-----|------------------|-----|------------|---------|-------------|---------------|-----|
| Type Plasma Gas: Air | | | | | | | Type Secondary Gas: Single Gas Torch | | | | | | | | |
| Thickness | | Tip | Output | Amperage | Speed (Per Minute) | | Standoff | | Plasma Gas Press | | Flow (CFH) | | Pierce | Pierce Height | |
| Inches | mm | (Cat. No.) | Volts(VDC) | (Amps) | Inches | Meters | Inches | mm | psi* | bar | Plasma | Total** | Delay (Sec) | Inches | mm |
| 0.036 | 0.9 | 9-8208 | 109 | 40 | 180 | 4.57 | 0.125 | 3.2 | 70 | 4.8 | 55 | 170 | 0.00 | 0.2 | 5.1 |
| 0.05 | 1.3 | 9-8208 | 105 | 40 | 165 | 4.19 | 0.125 | 3.2 | 70 | 4.8 | 55 | 170 | 0.00 | 0.2 | 5.1 |
| 0.06 | 1.5 | 9-8208 | 115 | 40 | 120 | 3.05 | 0.125 | 3.2 | 70 | 4.8 | 55 | 170 | 0.10 | 0.2 | 5.1 |
| 0.078 | 2.0 | 9-8208 | 120 | 40 | 65 | 1.65 | 0.187 | 4.8 | 70 | 4.8 | 55 | 170 | 0.30 | 0.2 | 5.1 |
| 0.135 | 3.4 | 9-8208 | 125 | 40 | 25 | 0.64 | 0.187 | 4.8 | 70 | 4.8 | 55 | 170 | 0.40 | 0.2 | 5.1 |
| 0.188 | 4.8 | 9-8208 | 132 | 40 | 20 | 0.51 | 0.187 | 4.8 | 70 | 4.8 | 55 | 170 | 0.60 | 0.2 | 5.1 |
| 0.25 | 6.4 | 9-8208 | 130 | 40 | 15 | 0.38 | 0.187 | 4.8 | 70 | 4.8 | 55 | 170 | 1.00 | 0.2 | 5.1 |
| 0.375 | 9.5 | 9-8208 | 130 | 40 | 10 | 0.25 | 0.187 | 4.8 | 70 | 4.8 | 55 | 170 | NR | NR | NR |

| Type Torch: SL60 With Shielded Tip | | | | | | | Type Material: Aluminum | | | | | | | | |
|------------------------------------|-----|------------|------------|----------|--------------------|--------|--------------------------------------|-----|------------------|-----|------------|---------|-------------|---------------|-----|
| Type Plasma Gas: Air | | | | | | | Type Secondary Gas: Single Gas Torch | | | | | | | | |
| Thickness | | Tip | Output | Amperage | Speed (Per Minute) | | Standoff | | Plasma Gas Press | | Flow (CFH) | | Pierce | Pierce Height | |
| Inches | mm | (Cat. No.) | Volts(VDC) | (Amps) | Inches | Meters | Inches | mm | psi* | bar | Plasma | Total** | Delay (Sec) | Inches | mm |
| 0.032 | 0.8 | 9-8208 | 116 | 40 | 220 | 5.59 | 0.187 | 4.8 | 70 | 4.8 | 55 | 170 | 0.00 | 0.2 | 5.1 |
| 0.051 | 1.3 | 9-8208 | 116 | 40 | 210 | 5.33 | 0.187 | 4.8 | 70 | 4.8 | 55 | 170 | 0.00 | 0.2 | 5.1 |
| 0.064 | 1.6 | 9-8208 | 118 | 40 | 180 | 4.57 | 0.187 | 4.8 | 70 | 4.8 | 55 | 170 | 0.10 | 0.2 | 5.1 |
| 0.079 | 2.0 | 9-8208 | 116 | 40 | 150 | 3.81 | 0.19 | 4.8 | 70 | 4.8 | 55 | 170 | 0.30 | 0.2 | 5.1 |
| 0.125 | 3.2 | 9-8208 | 130 | 40 | 75 | 1.91 | 0.19 | 4.8 | 70 | 4.8 | 55 | 170 | 0.40 | 0.2 | 5.1 |
| 0.188 | 4.8 | 9-8208 | 132 | 40 | 60 | 1.52 | 0.187 | 4.8 | 70 | 4.8 | 55 | 170 | 0.60 | 0.2 | 5.1 |
| 0.250 | 6.4 | 9-8208 | 134 | 40 | 28 | 0.71 | 0.187 | 4.8 | 70 | 4.8 | 55 | 170 | 1.00 | 0.2 | 5.1 |
| 0.375 | 9.5 | 9-8208 | 143 | 40 | 11 | 0.28 | 0.187 | 4.8 | 70 | 4.8 | 55 | 170 | NR | NR | NR |

CUTMASTER 20mm

| Type Torch: SL60 With Shielded Tip | | | | | | | Type Material: Mild Steel | | | | | | | | |
|------------------------------------|------|------------|-------------|----------|--------------------|--------|--------------------------------------|-----|------------------|-----|------------|---------|-------------|---------------|-----|
| Type Plasma Gas: Air | | | | | | | Type Secondary Gas: Single Gas Torch | | | | | | | | |
| Thickness | | Tip | Output | Amperage | Speed (Per Minute) | | Standoff | | Plasma Gas Press | | Flow (CFH) | | Pierce | Pierce Height | |
| Inches | mm | (Cat. No.) | Volts (VDC) | (Amps) | Inches | Meters | Inches | mm | psi* | bar | Plasma | Total** | Delay (Sec) | Inches | mm |
| 0.060 | 1.5 | 9-8210 | 124 | 60 | 250 | 6.35 | 0.19 | 4.8 | 75 | 5.2 | 90 | 245 | 0.00 | 0.2 | 5.1 |
| 0.075 | 1.9 | 9-8210 | 126 | 60 | 237 | 6.02 | 0.19 | 4.8 | 75 | 5.2 | 90 | 245 | 0.10 | 0.2 | 5.1 |
| 0.120 | 3.0 | 9-8210 | 126 | 60 | 230 | 5.84 | 0.19 | 4.8 | 75 | 5.2 | 90 | 245 | 0.10 | 0.2 | 5.1 |
| 0.135 | 3.4 | 9-8210 | 128 | 60 | 142 | 3.61 | 0.19 | 4.8 | 75 | 5.2 | 90 | 245 | 0.10 | 0.2 | 5.1 |
| 0.188 | 4.8 | 9-8210 | 128 | 60 | 125 | 3.18 | 0.19 | 4.8 | 75 | 5.2 | 90 | 245 | 0.20 | 0.2 | 5.1 |
| 0.250 | 6.4 | 9-8210 | 123 | 60 | 80 | 2.03 | 0.19 | 4.8 | 75 | 5.2 | 90 | 245 | 0.30 | 0.2 | 5.1 |
| 0.375 | 9.5 | 9-8210 | 132 | 60 | 34 | 0.86 | 0.19 | 4.8 | 75 | 5.2 | 90 | 245 | 0.50 | 0.2 | 5.1 |
| 0.500 | 12.7 | 9-8210 | 137 | 60 | 23 | 0.58 | 0.19 | 4.8 | 75 | 5.2 | 90 | 245 | 0.75 | 0.2 | 5.1 |
| 0.625 | 15.9 | 9-8210 | 139 | 60 | 14 | 0.36 | 0.19 | 4.8 | 75 | 5.2 | 90 | 245 | NR | NR | NR |
| 0.750 | 19.1 | 9-8210 | 145 | 60 | 14 | 0.36 | 0.19 | 4.8 | 75 | 5.2 | 90 | 245 | NR | NR | NR |
| 1.000 | 25.4 | 9-8210 | 156 | 60 | 4 | 0.10 | 0.19 | 4.8 | 75 | 5.2 | 90 | 245 | NR | NR | NR |

| Type Torch: SL60 With Shielded Tip | | | | | | | Type Material: Stainless Steel | | | | | | | | |
|------------------------------------|------|------------|------------|----------|--------------------|--------|--------------------------------------|-----|------------------|-----|------------|---------|-------------|---------------|-----|
| Type Plasma Gas: Air | | | | | | | Type Secondary Gas: Single Gas Torch | | | | | | | | |
| Thickness | | Tip | Output | Amperage | Speed (Per Minute) | | Standoff | | Plasma Gas Press | | Flow (CFH) | | Pierce | Pierce Height | |
| Inches | mm | (Cat. No.) | Volts(VDC) | (Amps) | Inches | Meters | Inches | mm | psi* | bar | Plasma | Total** | Delay (Sec) | Inches | mm |
| 0.06 | 1.5 | 9-8210 | 110 | 60 | 165 | 4.19 | 0.13 | 3.2 | 75 | 5.2 | 90 | 245 | 0.00 | 0.20 | 5.1 |
| 0.075 | 1.9 | 9-8210 | 116 | 60 | 155 | 3.94 | 0.13 | 3.2 | 75 | 5.2 | 90 | 245 | 0.10 | 0.20 | 5.1 |
| 0.120 | 3.0 | 9-8210 | 115 | 60 | 125 | 3.18 | 0.13 | 3.2 | 75 | 5.2 | 90 | 245 | 0.10 | 0.20 | 5.1 |
| 0.135 | 3.4 | 9-8210 | 118 | 60 | 80 | 2.03 | 0.13 | 3.2 | 75 | 5.2 | 90 | 245 | 0.10 | 0.20 | 5.1 |
| 0.188 | 4.8 | 9-8210 | 120 | 60 | 75 | 1.91 | 0.13 | 3.2 | 75 | 5.2 | 90 | 245 | 0.20 | 0.20 | 5.1 |
| 0.250 | 6.4 | 9-8210 | 121 | 60 | 60 | 1.52 | 0.13 | 3.2 | 75 | 5.2 | 90 | 245 | 0.30 | 0.20 | 5.1 |
| 0.375 | 9.5 | 9-8210 | 129 | 60 | 28 | 0.71 | 0.13 | 3.2 | 75 | 5.2 | 90 | 245 | 0.50 | 0.20 | 5.1 |
| 0.500 | 12.7 | 9-8210 | 135 | 60 | 17 | 0.43 | 0.19 | 4.8 | 75 | 5.2 | 90 | 245 | 0.75 | 0.20 | 5.1 |
| 0.625 | 15.9 | 9-8210 | 135 | 60 | 14 | 0.36 | 0.19 | 4.8 | 75 | 5.2 | 90 | 245 | NR | NR | NR |
| 0.750 | 19.1 | 9-8210 | 142 | 60 | 10 | 0.25 | 0.19 | 4.8 | 75 | 5.2 | 90 | 245 | NR | NR | NR |

| Type Torch: SL60 With Shielded Tip | | | | | | | Type Material: Aluminum | | | | | | | | |
|------------------------------------|------|------------|------------|----------|--------------------|--------|--------------------------------------|-----|------------------|-----|------------|---------|-------------|---------------|-----|
| Type Plasma Gas: Air | | | | | | | Type Secondary Gas: Single Gas Torch | | | | | | | | |
| Thickness | | Tip | Output | Amperage | Speed (Per Minute) | | Standoff | | Plasma Gas Press | | Flow (CFH) | | Pierce | Pierce Height | |
| Inches | mm | (Cat. No.) | Volts(VDC) | (Amps) | Inches | Meters | Inches | mm | psi* | bar | Plasma | Total** | Delay (Sec) | Inches | mm |
| 0.060 | 1.5 | 9-8210 | 105 | 60 | 350 | 8.89 | 0.13 | 3.2 | 75 | 5.2 | 90 | 245 | 0.00 | 0.20 | 5.1 |
| 0.075 | 1.9 | 9-8210 | 110 | 60 | 350 | 8.89 | 0.13 | 3.2 | 75 | 5.2 | 90 | 245 | 0.10 | 0.20 | 5.1 |
| 0.120 | 3.0 | 9-8210 | 110 | 60 | 275 | 6.99 | 0.13 | 3.2 | 75 | 5.2 | 90 | 245 | 0.10 | 0.20 | 5.1 |
| 0.188 | 3.4 | 9-8210 | 122 | 60 | 140 | 3.56 | 0.13 | 3.2 | 75 | 5.2 | 90 | 245 | 0.20 | 0.20 | 5.1 |
| 0.250 | 6.4 | 9-8210 | 134 | 60 | 80 | 2.03 | 0.19 | 4.8 | 75 | 5.2 | 90 | 245 | 0.30 | 0.20 | 5.1 |
| 0.375 | 9.5 | 9-8210 | 140 | 60 | 45 | 1.14 | 0.19 | 4.8 | 75 | 5.2 | 90 | 245 | 0.50 | 0.20 | 5.1 |
| 0.500 | 12.7 | 9-8210 | 144 | 60 | 26 | 0.66 | 0.19 | 4.8 | 75 | 5.2 | 90 | 245 | 0.80 | 0.20 | 5.1 |
| 0.625 | 15.9 | 9-8210 | 145 | 60 | 19 | 0.48 | 0.19 | 4.8 | 75 | 5.2 | 90 | 245 | NR | NR | NR |
| 0.750 | 19.1 | 9-8210 | 150 | 60 | 15 | 0.38 | 0.19 | 4.8 | 75 | 5.2 | 90 | 245 | NR | NR | NR |

NOTE

* Gas pressure shown is for torches with leads up to 25' / 7.6 m long. For 50' / 15.2 m leads, refer to section 4.02 "Operating Pressure".

** Total flow rate includes plasma and secondary gas flow.

This Page Intentionally Blank

PATENT INFORMATION**Plasma Cutting Torch Patents**

The following parts are covered under U.S. and Foreign Patents as follows:

| Catalog # | Description | Patent(s) |
|------------------|--------------------|---|
| 9-8215 | Electrode | US Pat No(s) 6163008; 6987238 Other Pat(s) Pending |
| 9-8213 | Cartridge | US Pat No(s) 6903301; 6717096; 6936786; 6703581; D496842; D511280; D492709; D499620; D504142 Other Pat(s) Pending |
| 9-8205 | Tip | US Pat No(s) 6774336; 7145099; 6933461 Other Pat(s) Pending |
| 9-8206 | Tip | US Pat No(s) 6774336; 7145099; 6933461 Other Pat(s) Pending |
| 9-8207 | Tip | US Pat No(s) 6774336; 7145099; 6933461 Other Pat(s) Pending |
| 9-8252 | Tip | US Pat No(s) 6774336; 7145099; 6933461 Other Pat(s) Pending |
| 9-8208 | Tip | US Pat No(s) 6774336; 7145099; 6933461 Other Pat(s) Pending |
| 9-8209 | Tip | US Pat No(s) 6774336; 7145099; 6933461 Other Pat(s) Pending |
| 9-8210 | Tip | US Pat No(s) 6774336; 7145099; 6933461 Other Pat(s) Pending |
| 9-8231 | Tip | US Pat No(s) 6774336; 7145099; 6933461 Other Pat(s) Pending |
| 9-8211 | Tip | US Pat No(s) 6774336; 7145099; 6933461 Other Pat(s) Pending |
| 9-8212 | Tip | US Pat No(s) 6774336; 7145099; 6933461 Other Pat(s) Pending |
| 9-8253 | Tip | US Pat No(s) 6774336; 7145099; 6933461 Other Pat(s) Pending |
| 9-8225 | Tip | US Pat No(s) 6774336; 7145099; 6933461 Other Pat(s) Pending |
| 9-8226 | Tip | US Pat No(s) 6774336; 7145099; 6933461 Other Pat(s) Pending |
| 9-8227 | Tip | US Pat No(s) 6774336; 7145099; 6933461 Other Pat(s) Pending |
| 9-8228 | Tip | US Pat No(s) 6774336; 7145099; 6933461 Other Pat(s) Pending |
| 9-8241 | Shield Cap | US Pat No(s) 6914211; D505309 Other Pat(s) Pending |
| 9-8243 | Shield Cap | US Pat No(s) 6914211; D493183 Other Pat(s) Pending |
| 9-8235 | Shield Cap | US Pat No(s) 6914211; D505309 Other Pat(s) Pending |
| 9-8236 | Shield Cap | US Pat No(s) 6914211; D505309 Other Pat(s) Pending |
| 9-8237 | Shield Cup | US Pat No(s) 6914211; D501632; D511633 Other Pat(s) Pending |
| 9-8238 | Shield Cap | US Pat No(s) 6914211; D496951 Other Pat(s) Pending |
| 9-8239 | Shield Cap | US Pat No(s) 6914211; D496951 Other Pat(s) Pending |
| 9-8244 | Shield Cap | US Pat No(s) 6914211; D505309 Other Pat(s) Pending |

| Catalog # | Description | Patent(s) |
|------------------|--------------------|---|
| 9-8245 | Shield Cap | US Pat No(s) 6914211; D496951 Other Pat(s) Pending |

The following parts are also licensed under U.S. Patent No. 5,120,930 and 5,132,512:

Catalog #Description

9-8235Shield Cap
9-8236Shield Cap
9-8237Shield Cup
9-8238Shield Cap
9-8239Shield Cap
9-8244Shield Cap
9-8245Shield Cap

This Page Intentionally Blank

SECTION 5 SYSTEM: SERVICE

5.01 General Maintenance



Warning!
Disconnect input power before maintaining.

Maintain more often
if used under severe
conditions

Each Use

Visual check of
torch tip and electrode

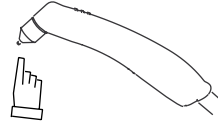

Weekly

Visually inspect the torch body tip,
electrode, start cartridge and shield cup

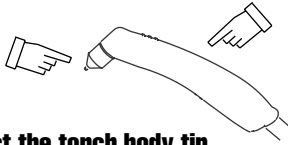

Visually inspect the
cables and leads.
Replace as needed

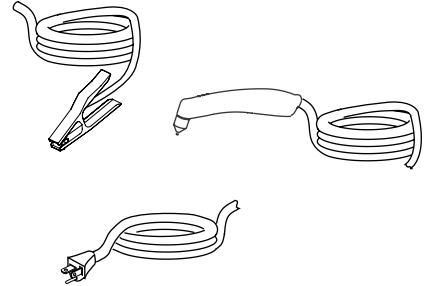

3 Months

Replace all
broken parts

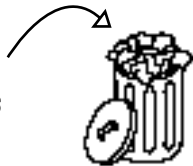

Clean
exterior
of power supply

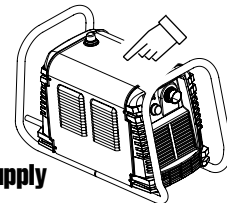

6 Months

Visually check and
Carefully clean the
interior

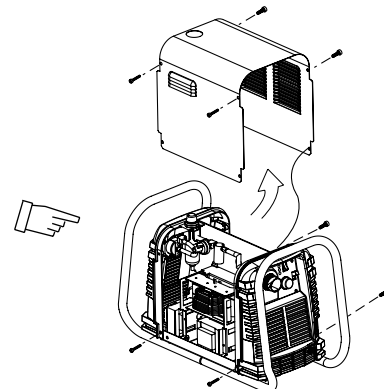

CUTMASTER 20mm

5.02 Maintenance Schedule

NOTE

The actual frequency of maintenance may need to be adjusted according to the operating environment.

Daily Operational Checks or Every Six Cutting Hours:

1. Check torch consumable parts, replace if damaged or worn.
2. Check plasma and secondary supply and pressure/flow.
3. Purge plasma gas line to remove any moisture build-up.

Weekly or Every 30 Cutting Hours:

1. Check fan for proper operation and adequate air flow.
2. Inspect torch for any cracks or exposed wires, replace if necessary.
3. Inspect input power cable for damage or exposed wires, replace if necessary.

Six Months or Every 720 Cutting Hours:

1. Check the in-line air filter(s), clean or replace as required.
2. Check cables and hoses for leaks or cracks, replace if necessary.
3. Check all contactor points for severe arcing or pits, replace if necessary.
4. Vacuum dust and dirt *out* of the entire machine.



CAUTION

Do not blow air into the power supply during cleaning. Blowing air into the unit can cause metal particles to interfere with sensitive electrical components and cause damage to the unit.

5.03 Common Faults

| Problem - Symptom | Common Cause |
|---------------------------|--|
| Insufficient Penetration | <ol style="list-style-type: none"> 1. Cutting speed too fast. 2. Torch tilted too much. 3. Metal too thick. 4. Worn torch parts 5. Cutting current too low. 6. Non - Genuine Thermal Dynamics parts used 7. Incorrect gas pressure |
| Main Arc Extinguishes | <ol style="list-style-type: none"> 1. Cutting speed too slow. 2. Torch standoff too high from workpiece. 3. Cutting current too high. 4. Work cable disconnected. 5. Worn torch parts. 6. Non - Genuine Thermal Dynamics parts used |
| Excessive Dross Formation | <ol style="list-style-type: none"> 1. Cutting speed too slow. 2. Torch standoff too high from workpiece. 3. Worn torch parts. 4. Improper cutting current. 5. Non - Genuine Thermal Dynamics parts used 6. Incorrect gas pressure |
| Short Torch Parts Life | <ol style="list-style-type: none"> 1. Oil or moisture in air source. 2. Exceeding system capability (material too thick). 3. Excessive pilot arc time 4. Gas pressure too low. 5. Improperly assembled torch. 6. Non - Genuine Thermal Dynamics parts used |
| Difficult Starting | <ol style="list-style-type: none"> 1. Worn torch parts. 2. Non - Genuine Thermal Dynamics parts used. 3. Incorrect gas pressure. |

5.04 Fault Indicator

At initial power up, two lights will temporarily illuminate for 2-3 seconds to show the version of software used.

To determine the first digit, count the function indicators left to right, 1 through 5. To determine the second digit count the pressure indicators, reading from bottom to top, 0 through 7. In the example below the Temp indicator and 75 psi indicators are ON indicating the version would be 2.3.

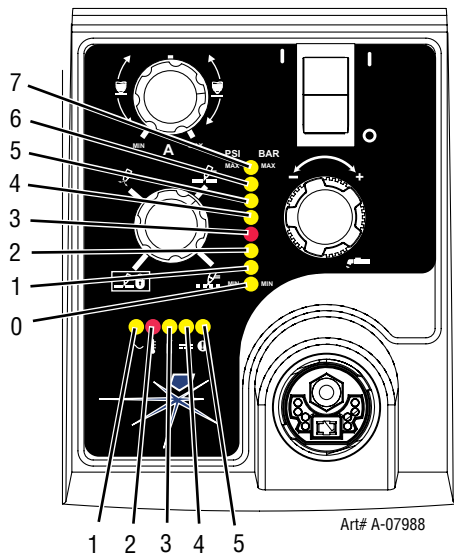

When the  "Fault" indicator is ON or blinking it will be accompanied by one of the pressure indicator lights depending on what the Fault is. The following table explains each of those Faults.

| Pressure Indicator | Fault |
|--------------------|---------------------|
| Max | Over Pressure |
| 90 | Internal Error |
| 85 | Shorted Torch |
| 80 | Consumables Missing |
| 75 | Start Error |
| 70 | Parts in Place |
| 65 | Input Power |
| Min | Under Pressure |

NOTE

Fault explanations are covered in the following tables.

5.05 Basic Troubleshooting Guide



WARNING

There are extremely dangerous voltage and power levels present inside this unit. Do not attempt to diagnose or repair unless you have had training in power electronics measurement and troubleshooting techniques.

| Problem - Symptom | Possible Cause | Recommended Action |
|--|--|---|
| ON / OFF Switch is ON but the A/C Indicator does not light | <ol style="list-style-type: none"> 1. Primary power disconnect is in OFF position. 2. Primary fuses / breakers are blown or tripped. 3. Units internal fuse blown. 4. Faulty components in unit. | <ol style="list-style-type: none"> 1. Turn primary power disconnect switch to ON position. 2. a) Have qualified person check primary fuses / breakers. b) Connect unit to known good primary power receptacle 3. a) Replace fuse. b) If fuse blows again, return to authorized service center for repair or replacement. 4. Return to authorized service center for repair or replacement. |
| Fault indicator flashing, 65 PSI indicator flashing | <ol style="list-style-type: none"> 1. Improper Input Voltage. 2. Primary input voltage problem. 3. Faulty components in unit. | <ol style="list-style-type: none"> 1. Check for proper primary input voltage. 2. Have qualified person check primary voltage to insure it meets unit requirements see section 2.05. 3. Return to authorized service center for repair or replacement. |
| TEMPERATURE indicator ON. FAULT indicator flashing. | <ol style="list-style-type: none"> 1. Air flow through or around the unit is obstructed. 2. Duty cycle of the unit has been exceeded 3. Failed components in unit | <ol style="list-style-type: none"> 1. Refer to clearance information – section 2.04 2. Allow unit to cool. 3. Return to authorized service center for repair or replacement. |
| GAS LED OFF, FAULT and MIN pressure indicators flashing. | <ol style="list-style-type: none"> 1. Gas supply not connected to unit. 2. Gas supply not turned ON. 3. Gas supply pressure too low. 4. AIR PRESSURE CONTROL regulator set too low. 5. Failed components in unit. | <ol style="list-style-type: none"> 1. Connect gas supply to unit. 2. Turn gas supply ON. 3. Set air supply inlet pressure to unit to 120 psi. 4. Adjust regulator to set air pressure - see section 4.02. 5. Return to authorized service center for repair or replacement. |
| FAULT and 70 PSI indicators flashing. | <ol style="list-style-type: none"> 1. Shield Cup loose. 2. Torch not properly connected to power supply. 3. Problem in torch and leads PIP circuit. 4. Failed components in unit. | <ol style="list-style-type: none"> 1. Hand tighten the shield cup until it is snug. 2. Insure torch ATC is securely fastened to unit. 3. Replace torch and leads or return to authorized service center for repair or replacement. 4. Return to authorized service center for repair or replacement. |
| FAULT and 75 PSI indicators flashing. | <ol style="list-style-type: none"> 1. Start signal is active when ON/OFF SWITCH is turned to ON position. 2. Problem in the torch and leads switch circuit. 3. Failed components in unit. | <ol style="list-style-type: none"> 1. Start can be active for one of the following: <ul style="list-style-type: none"> • Hand torch switch held closed • Hand pendant switch held closed • CNC START signal is active low Release the START signal source 2. Replace torch and leads or return to authorized service center for repair or replacement. 3. Return to authorized service center for repair or replacement. |

| Problem - Symptom | Possible Cause | Recommended Action |
|---|---|---|
| FAULT & 80 PSI indicators flashing. Gas flow is cycling ON and OFF. | <ol style="list-style-type: none"> 1. Torch shield cup is loose. 2. Torch tip, electrode or starter cartridge missing. 3. Torch start cartridge is stuck. 4. Open conductor in torch leads. 5. Problem in the torch and leads switch circuit. 6. Failed components in unit. | <ol style="list-style-type: none"> 1. Tighten shield cup by hand. Do not overtighten. 2. Turn OFF power supply. Remove shield cup. Install missing parts. 3. Turn OFF power supply. Bleed down system pressure. Remove shield cup, tip and start cartridge. Check start cartridge lower end fitting for free movement. Replace if fitting does not move freely. 4. Replace torch and leads or return to authorized service center for repair or replacement. 5. Replace torch and leads or return to authorized service center for repair or replacement. 6. Return to authorized service center for repair or replacement. |
| Nothing happens when torch switch or remote switch is closed (Or CNC START signal is active) No gas flow, DC LED OFF. | <ol style="list-style-type: none"> 1. Problem in the torch and leads switch circuit (Remote pendant switch circuit). 2. CNC Controller device not providing Start signal. 3. Failed components in unit. | <ol style="list-style-type: none"> 1. Take Torch and Leads (Remote Pendant) to Authorized Repair Facility. 2. Contact Controller manufacturer. 3. Return to authorized service center for repair or replacement. |
| FAULT and 85 PSI indicators flashing. | <ol style="list-style-type: none"> 1. Upper O-Ring on torch head is in wrong position. 2. Torch starter cartridge is stuck. 3. Worn or faulty torch parts. 4. Shorted Torch. 5. Temporary Short indicated by 5 blinks per second. 6. Power Supply Failure (Standard rate of blinking) | <ol style="list-style-type: none"> 1. Remove shield cup from torch; check upper O-Ring position; correct if necessary. 2. Turn OFF power supply. Bleed down system pressure. Remove shield cup, tip and starter cartridge. Check starter cartridge lower end fitting for free movement. Replace if fitting does not move freely. 3. Inspect torch consumable parts. Replace if necessary. 4. Replace torch and leads or return to an authorized service center for repair. 5. Release torch switch and reactivate. 6. Return to authorized service center for repair or replacement. |
| No Fault lights ON, no arc in torch. | <ol style="list-style-type: none"> 1. Failed components in unit. | <ol style="list-style-type: none"> 1. Return to an authorized service center for repair. |
| FAULT and 85 PSI indicators flashing | <ol style="list-style-type: none"> 1. Internal Error | <ol style="list-style-type: none"> 1. Turn the ON / OFF switch OFF then back ON again. If that does not clear the fault, return to an authorized service center for repair. |
| Pilot arc is ON but cutting arc will not establish | <ol style="list-style-type: none"> 1. Work cable not connected to work piece. 2. Work cable/connector broken. 3. Failed components in unit. | <ol style="list-style-type: none"> 1. Connect work cable. 2. Replace work cable. 3. Return to an authorized service center for repair. |
| Torch cutting is diminished | <ol style="list-style-type: none"> 1. Incorrect current setting. 2. Worn torch consumables. 3. Poor work cable connection to work piece. 4. Torch being moved too fast. 5. Excessive oil or water in torch. 6. Failed components in unit. | <ol style="list-style-type: none"> 1. Check and adjust to proper setting. 2. Check torch consumables and replace as needed. 3. Check the connection of the Work Lead to the work piece. 4. Reduce cutting speed. 5. Refer to "Check air quality" in section 3 Torch. 6. Return to an authorized service center for repair. |

5.06 Power Supply Basic Parts Replacement



WARNING

Disconnect primary power to the system before disassembling the torch, leads, or power supply.

This section describes procedures for basic parts replacement. For more detailed parts replacement procedures, refer to the Power Supply Service Manual.

A. Cover Removal

1. Remove the upper and lower screws which secure the cover to the main assembly. Do not loosen the lower screws inside the cut out slots in the bottom of the cover.

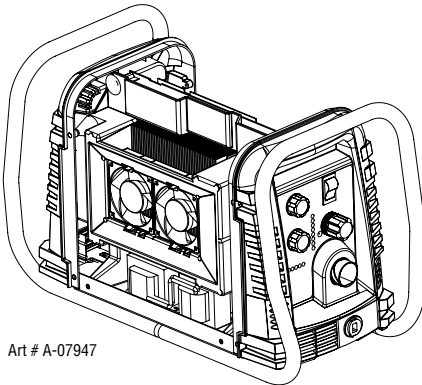
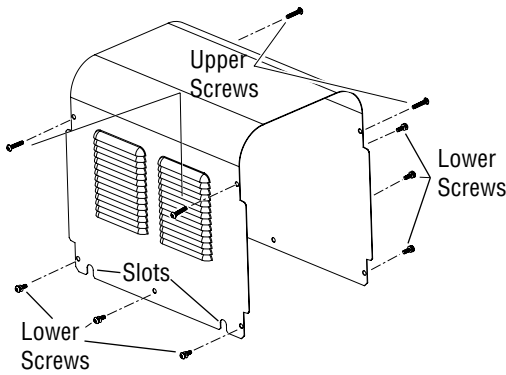

2. Carefully pull the Cover up and away from the unit.

B. Cover Installation

1. Reconnect the ground wire, if necessary.
2. Place the cover onto the power supply so that slots in the bottom edges of the cover engage the lower screws.
3. Tighten lower screws.
4. Reinstall and tighten the upper screws.

C. Filter Element Assembly Replacement

The Filter Element Assembly is in the rear panel. For better system performance, the filter element should be checked per the Maintenance Schedule (Subsection 5.02), and either cleaned or replaced.

1. Remove power from the power supply; turn OFF the gas supply and bleed down the system.
2. Remove the system cover. See "A Cover Removal" in this section.
3. Locate the internal air line and the fitting from the filter assembly. Number 1 in the following illustration.
4. Hold a wrench or similar tool against the locking ring on the filter assembly fitting, then pull on the hose to release it. (Numbers 2 and 3 in the following illustration).

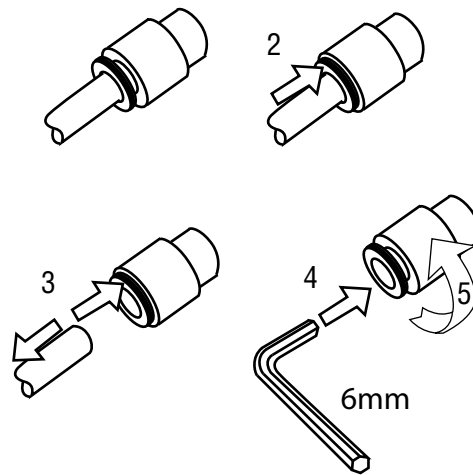
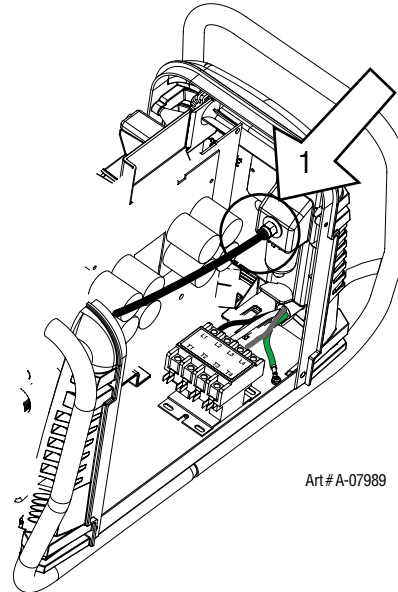

5. Remove the fitting from the filter element assembly by inserting a 6 mm hex wrench into the internal hex fitting and turning it counter clock-wise (left). Numbers 4 and 5 in the previous illustration.
6. Disconnect the input line from the filter element assembly.
7. Remove the filter element assembly through the rear opening.

NOTE

If replacing or cleaning just the filter element refer to the following illustration for disassembly.

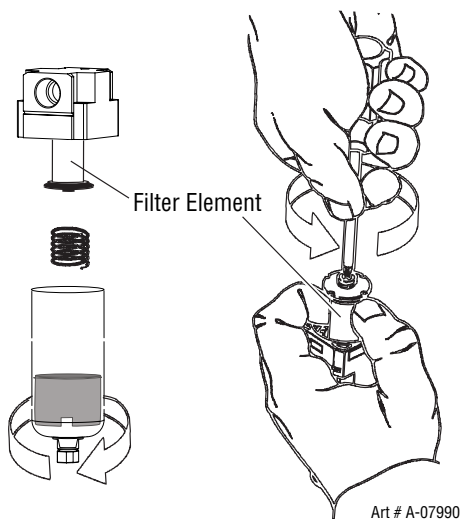

8. Install the new or cleaned assembly by reversing these procedures.
9. Turn ON the air supply and check for leaks before reinstalling the cover.

Optional Single-Stage Filter Element Replacement

These instructions apply to power supplies where the optional Single-Stage Filter has been installed.

The Power Supply shuts down automatically when the Filter Element becomes completely saturated. The Filter Element can be removed from its housing, dried, and reused. Allow 24 hours for Element to dry. Refer to Section 6, Parts List, for replacement filter element catalog number.

1. Remove power from power supply.
2. Shut OFF air supply and bleed down system before disassembling Filter to change Filter Element.
3. Disconnect gas supply hose.
4. Turn the Filter Housing Cover counter-clockwise and remove it. The Filter Element is located inside the Housing.

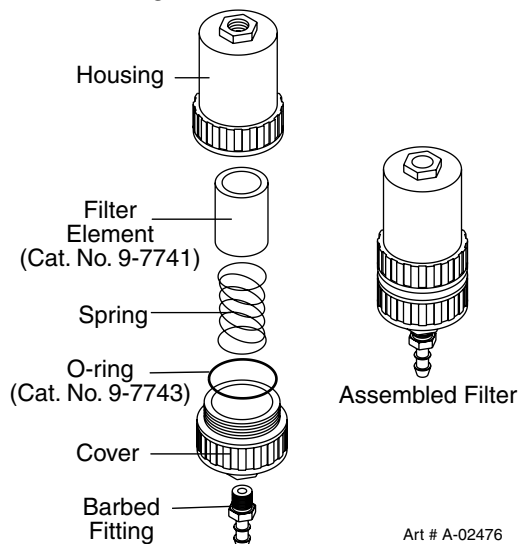

Optional Single-Stage Filter Element Replacement

5. Remove the Filter Element from the Housing and set Element aside to dry.
6. Wipe inside of housing clean, then insert the replacement Filter Element open side first.
7. Replace Housing on Cover.
8. Reattach gas supply.

NOTE

If unit leaks between housing and cover, inspect the O-Ring for cuts or other damage.

CUTMASTER 20mm

Optional Two-Stage Filter Element Replacement

The Two-Stage Air Filter has two Filter Elements. When the Filter Elements become dirty the Power Supply will continue to operate but cut quality may become unacceptable. Refer to Section 6, Parts List, for replacement filter element catalog number.

1. Shut OFF primary input power.
2. Shut OFF air supply and bleed down system.



WARNING

Always turn OFF the air supply and bleed the system before disassembling the Filter Assembly as injury could result.

3. Loosen the two bolts on the top of the Filter Assembly enough to allow the Filter Elements to move freely.
4. Note the location and orientation of the old Filter Elements.
5. Slide out the old Filter Elements.

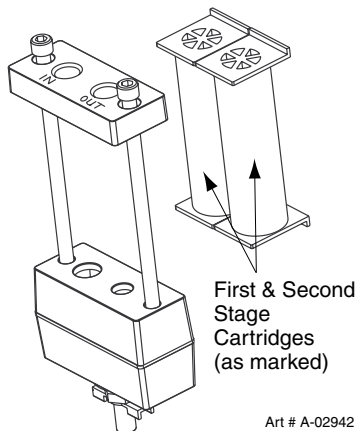

Optional Two-Stage Filter Replacement

6. Slide the replacement Filter Elements into the Filter Assembly, with the same orientation as noted in Step 4 above.
7. Hand tighten the two bolts evenly, then torque each bolt to 20 - 30 in-lbs (2.3 - 3.4 Nm). Improper torque may damage the gasket.
8. Slowly apply air pressure to the assembly, checking for leaks.

NOTE

A small amount of air leakage from the bottom fitting is normal.

This completes the parts replacement procedures.

SECTION 5 TORCH: SERVICE

5T.01 General Maintenance

NOTE

Refer to Previous "Section 5 System" for common and fault indicator descriptions.

Cleaning Torch

Even if precautions are taken to use only clean air with a torch, eventually the inside of the torch becomes coated with residue. This buildup can affect the pilot arc initiation and the overall cut quality of the torch.



WARNING

Disconnect primary power to the system before disassembling the torch or torch leads.

DO NOT touch any internal torch parts while the AC indicator light of the Power Supply is ON.

The inside of the torch should be cleaned with electrical contact cleaner using a cotton swab or soft wet rag. In severe cases, the torch can be removed from the leads and cleaned more thoroughly by pouring electrical contact cleaner into the torch and blowing it through with compressed air.



CAUTION

Dry the torch thoroughly before reinstalling.

O-Ring Lubrication

An o-ring on the Torch Head and ATC Male Connector requires lubrication on a scheduled basis. This will allow the o-rings to remain pliable and provide a proper seal. The o-rings will dry out, becoming hard and cracked if the lubricant is not used on a regular basis. This can lead to potential performance problems.

It is recommended to apply a very light film of o-ring lubricant (Catalog # 8-4025) to the o-rings on a weekly basis.

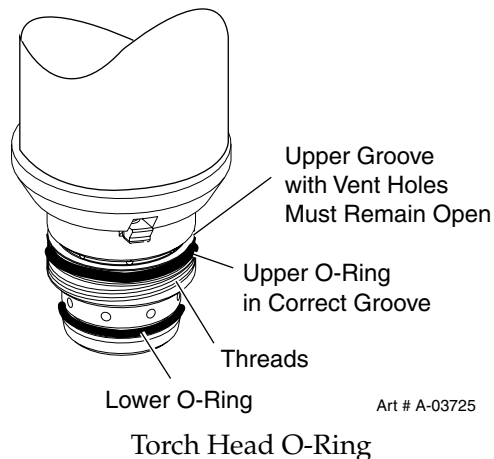

Art # A-03725

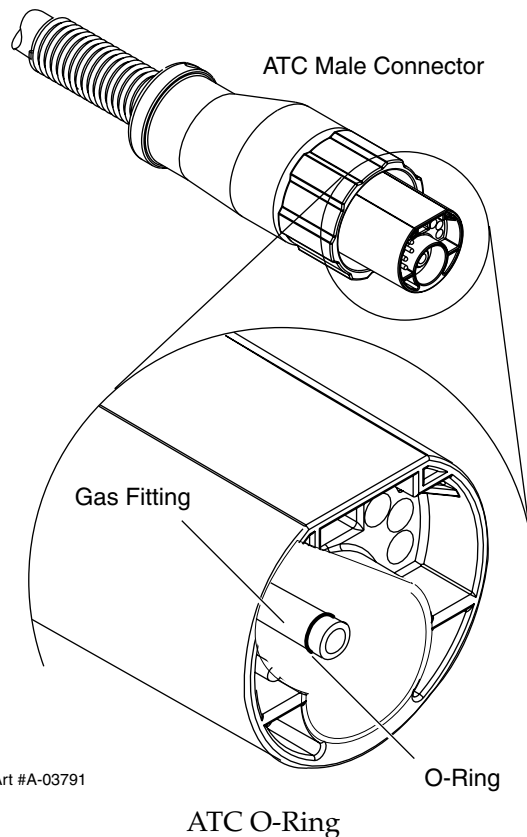

Art #A-03791

NOTE

DO NOT use other lubricants or grease, they may not be designed to operate within high temperatures or may contain "unknown elements" that may react with the atmosphere. This reaction can leave contaminants inside the torch. Either of these conditions can lead to inconsistent performance or poor parts life.

5T.02 Inspection and Replacement of Consumable Torch Parts



WARNING

Disconnect primary power to the system before disassembling the torch or torch leads.

DO NOT touch any internal torch parts while the AC indicator light of the Power Supply is ON.

Remove the consumable torch parts as follows:

NOTE

The shield cup holds the tip and starter cartridge in place. Position the torch with the shield cup facing upward to prevent these parts from falling out when the cup is removed.

1. Unscrew and remove the shield cup from the torch.

NOTE

Slag built up on the shield cup that cannot be removed may effect the performance of the system.

2. Inspect the cup for damage. Wipe it clean or replace if damaged.

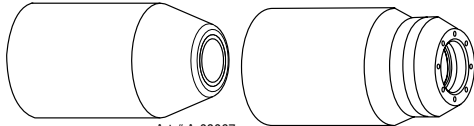

Art # A-08067

Shield Cups

3. On torches with a shield cup body and a shield cap or deflector, ensure that the cap or deflector is threaded snugly against the shield cup body. In shielded drag cutting operations (only), there may be an O-ring between the shield cup body and drag shield cap. Do not lubricate the O-ring.

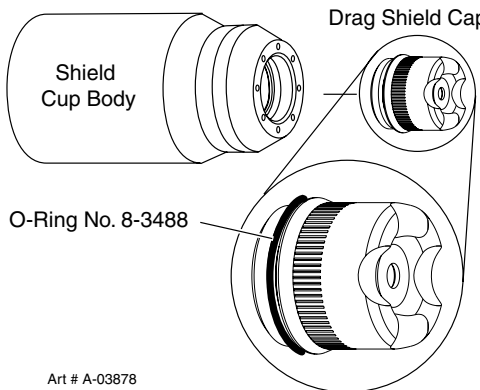

Art # A-03878

4. Remove the tip. Check for excessive wear (indicated by an elongated or oversized orifice). Clean or replace the tip if necessary.

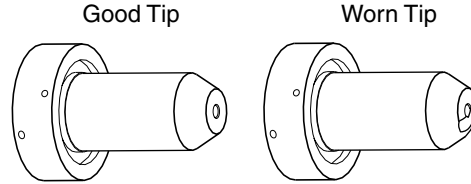

A-03406

Example of Tip Wear

5. Remove the starter cartridge. Check for excessive wear, plugged gas holes, or discoloration. Check the lower end fitting for free motion. Replace if necessary.

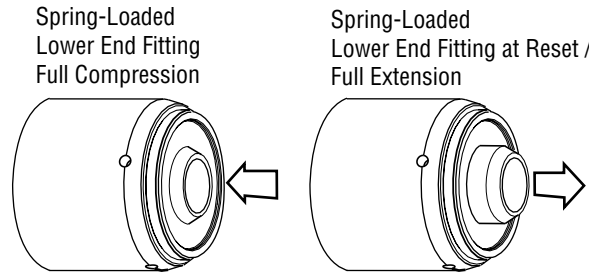

Art # A-08064_AC

6. Pull the Electrode straight out of the Torch Head. Check the face of the electrode for excessive wear. Refer to the following figure.



New Electrode

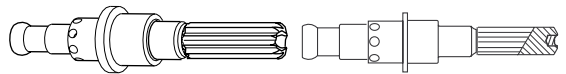

Worn Electrode

Art # A-03284

Electrode Wear

7. Reinstall the Electrode by pushing it straight into the torch head until it clicks.
8. Reinstall the desired starter cartridge and tip into the torch head.
9. Hand tighten the shield cup until it is seated on the torch head. If resistance is felt when installing the cup, check the threads before proceeding.

This completes the parts replacement procedures.

SECTION 6: PARTS LISTS

6.01 Introduction

A. Parts List Breakdown

The parts list provide a breakdown of all replaceable components. The parts lists are arranged as follows:

- Section "6.03 Power Supply Replacement"
- Section "6.04 Replacement Power Supply Parts"
- Section "6.05 Options and Accessories"
- Section "6.06 Replacement Parts for Hand Torch"
- Section "6.07 Replacement Parts - for Machine Torches with Unshielded Leads"
- Section "6.08 Replacement Shielded Machine Torch Leads Assemblies"
- Section "6.09 Torch Consumable Parts (SL60)"
- Section "6.10 Torch Consumable Parts (SL100)"

NOTE

Parts listed without item numbers are not shown, but may be ordered by the catalog number shown.

B. Returns

If a product must be returned for service, contact your distributor. Materials returned without proper authorization will not be accepted.

6.02 Ordering Information

Order replacement parts by catalog number and complete description of the part or assembly, as listed in the parts list for each type item. Also include the model and serial number of the power supply. Address all inquiries to your authorized distributor.

6.03 Power Supply Replacement

The following items are included with the replacement power supply: work cable & clamp, input power cable, gas pressure regulator / filter, and operating manual.

| Qty | Description | Catalog # |
|-----|--|-----------|
| 1 | CutMaster 20mm CE Power Supply with 400VAC 3 phase, 50 Hz input power cable | 3-5130-4 |
| 1 | CutMaster 20mm Non CE Power Supply With 400VAC 3 phase, 50 Hz input power cable | 3-5130-3 |

CUTMASTER 20mm

6.04 Replacement Power Supply Parts

| Qty | Description | Catalog # |
|-----|---|-----------|
| 1 | Regulator | 9-0115* |
| 1 | Filter Assembly Replacement Element | 9-0116 |
| 1 | Input Power Cord for 380/400 V Power Supply | 9-0218 |

6.05 Options and Accessories

| Qty | Description | Catalog # |
|-----|--|-----------|
| 1 | Single - Stage Filter Kit (includes Filter & Hose) | 7-7507 |
| 1 | Replacement Filter Body | 9-7740 |
| 1 | Replacement Filter Hose (not shown) | 9-7742 |
| 2 | Replacement Filter Element | 9-7741 |
| 1 | Two - Stage Filter Kit (includes Hose & Mounting Screws) | 9-9387 |
| 1 | Two - Stage Air Filter Assembly | 9-7527 |
| 1 | First Stage Cartridge | 9-1021 |
| 1 | Second Stage Cartridge | 9-1022 |
| 1 | Extended Work Cable (50 ft / 15.2 m) with Clamp | 9-8529 |
| 1 | Multi - Purpose Cart | 7-8888 |
| 1 | Automation Interface Kit | 9-8310 |
| 1 | 25' / 7.6 m CNC Cable for Automation Interface Kit | 9-1008 |
| 1 | 35' / 10.7 m CNC Cable for Automation Interface Kit | 9-1010 |
| 1 | 50' / 15.2 m CNC Cable for Automation Interface Kit | 9-1011 |
| 1 | Nylon Dust Cover | 9-7071 |

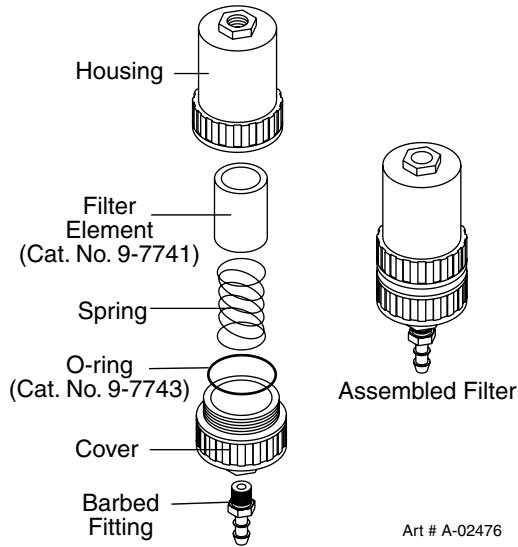

Optional Single - Stage Filter Kit

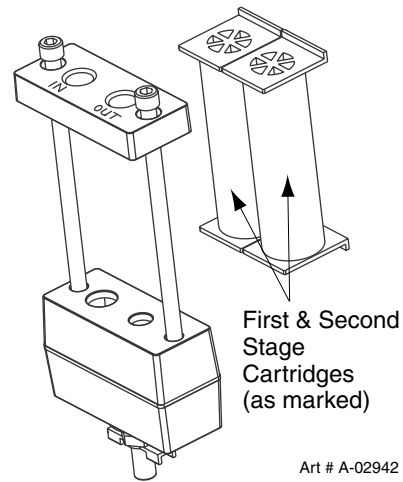

Optional Two - Stage Filter Kit

6.06 Replacement Parts for Hand Torch

| Item # | Qty | Description | Catalog # |
|--------|-----|---|-----------|
| 1 | 1 | Torch Handle Replacement Kit (includes items No. 2 & 3) | 9-7030 |
| 2 | 1 | Trigger Assembly Replacement Kit | 9-7034 |
| 3 | 1 | Handle Screw Kit (5 each, 6-32 x 1/2" cap screw, and wrench) | 9-8062 |
| 4 | 1 | Torch Head Assembly Replacement Kit (includes items No. 5 & 6) | 9-8219 |
| 5 | 1 | Large O-Ring | 8-3487 |
| 6 | 1 | Small O-Ring | 8-3486 |
| 7 | | Leads Assemblies with ATC connectors (includes switch assemblies) | |
| 1 | | SL60, 20 - foot Leads Assembly with ATC connector | 4-7834 |
| 1 | | SL60, 50 - foot Leads Assembly with ATC connector | 4-7835 |
| 1 | | SL100, 20 - foot Leads Assembly with ATC connector | 4-7836 |
| 1 | | SL100, 50 - foot Leads Assembly with ATC connector | 4-7837 |
| 8 | 1 | Switch Kit | 9-7031 |
| 10 | 1 | Torch Control Cable Adapter (includes item # 11) | 7-3447 |
| 11 | 1 | Through - Hole Protector | 9-8103 |

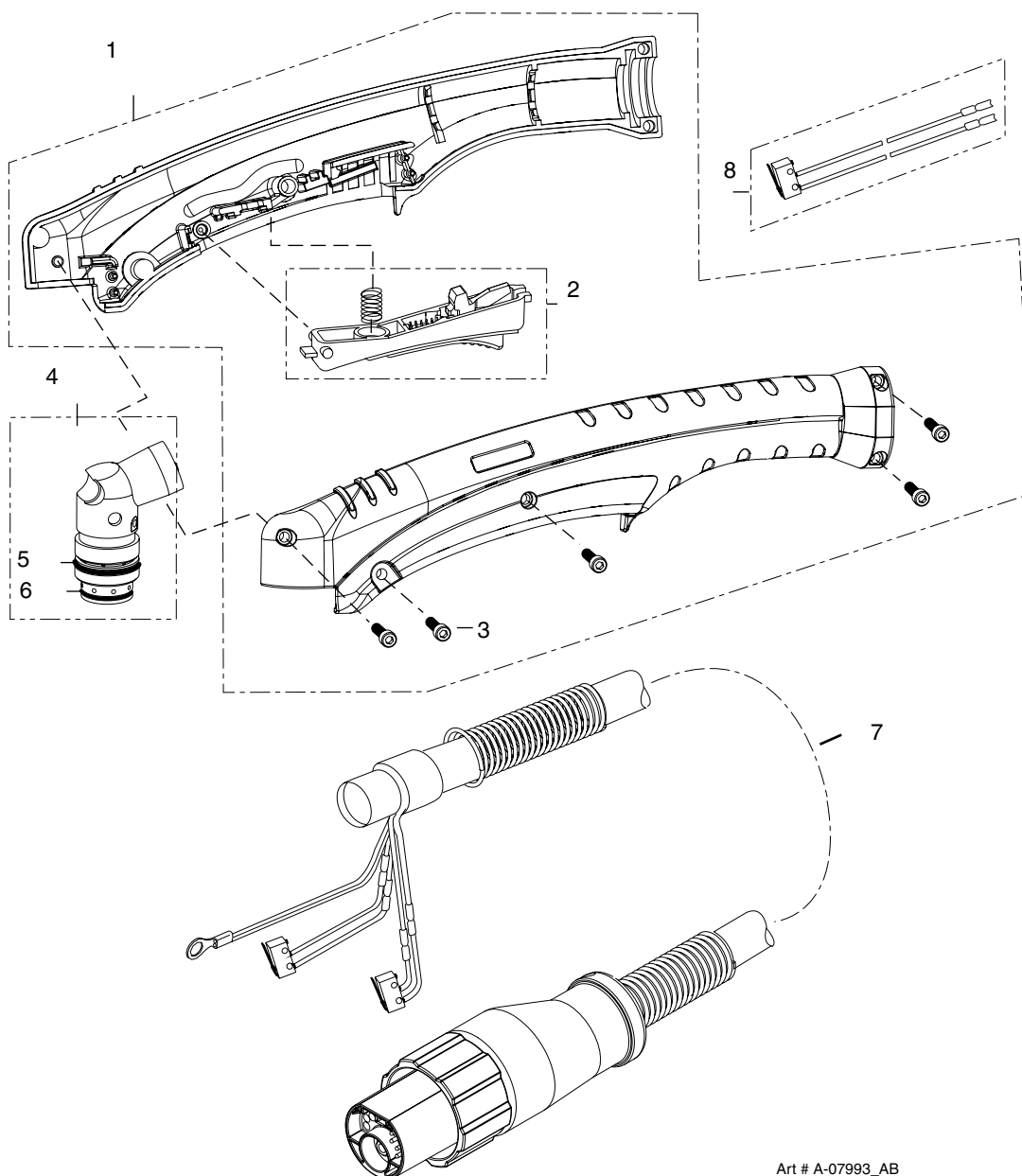

Art # A-07993_AB

CUTMASTER 20mm

6.07 Replacement Parts - for Machine Torches with Unshielded Leads

| Item No. | Qty | Description | Catalog No. |
|----------|-----|---|-------------|
| 1 | 1 | Torch Head Assembly without leads (includes items 2, 3, and 14) | 9-8220 |
| 2 | 1 | Large O-Ring | 8-3487 |
| 3 | 1 | Small O-Ring | 8-3486 |
| 4 | 1 | PIP Switch Kit | 9-7036 |
| 5 | | Unshielded Automated Leads Assemblies with ATC connectors | |
| 1 | | 5 - foot / 1.5 m Leads Assembly with ATC connector | 4-7850 |
| 1 | | 10 - foot / 3.05 m Leads Assembly with ATC connector | 4-7851 |
| 1 | | 25 - foot / 7.6 m Leads Assembly with ATC connector | 4-7852 |
| 1 | | 50 - foot / 15.2 m Leads Assembly with ATC connector | 4-7853 |
| 6 | | Unshielded Mechanized Leads Assemblies with ATC connectors | |
| 1 | | 5 - foot / 1.5 m Leads Assembly with ATC connector | 4-7842 |
| 1 | | 10 - foot / 3.05 m Leads Assembly with ATC connector | 4-7843 |
| 1 | | 25 - foot / 7.6 m Leads Assembly with ATC connector | 4-7844 |
| 1 | | 50 - foot / 15.2 m Leads Assembly with ATC connector | 4-7845 |
| 7 | 1 | 11" / 279 mm Rack | 9-7041 |
| 8 | 1 | 11" / 279 mm Mounting Tube | 9-7043 |
| 9 | 1 | End Cap Assembly | 9-7044 |
| 10 | 2 | Body, Mounting, Pinch Block | 9-4513 |
| 11 | 1 | Pin, Mounting, Pinch Block | 9-4521 |
| 12 | 1 | Torch Holder Sleeve | 7-2896 |
| 13 | 1 | PIP Plunger and Return Spring Kit | 9-7045 |
| 1 | | Pinion Assembly (Not shown) | 7-2827 |
| 1 | | 5" / 126 mm Positioning Tube (Not shown) | 9-7042 |

NOTE

* Does not include Control Cable Adapter or Through - Hole Protector.

Refer to Section 6.09 for Replacement Shielded Leads Assemblies.

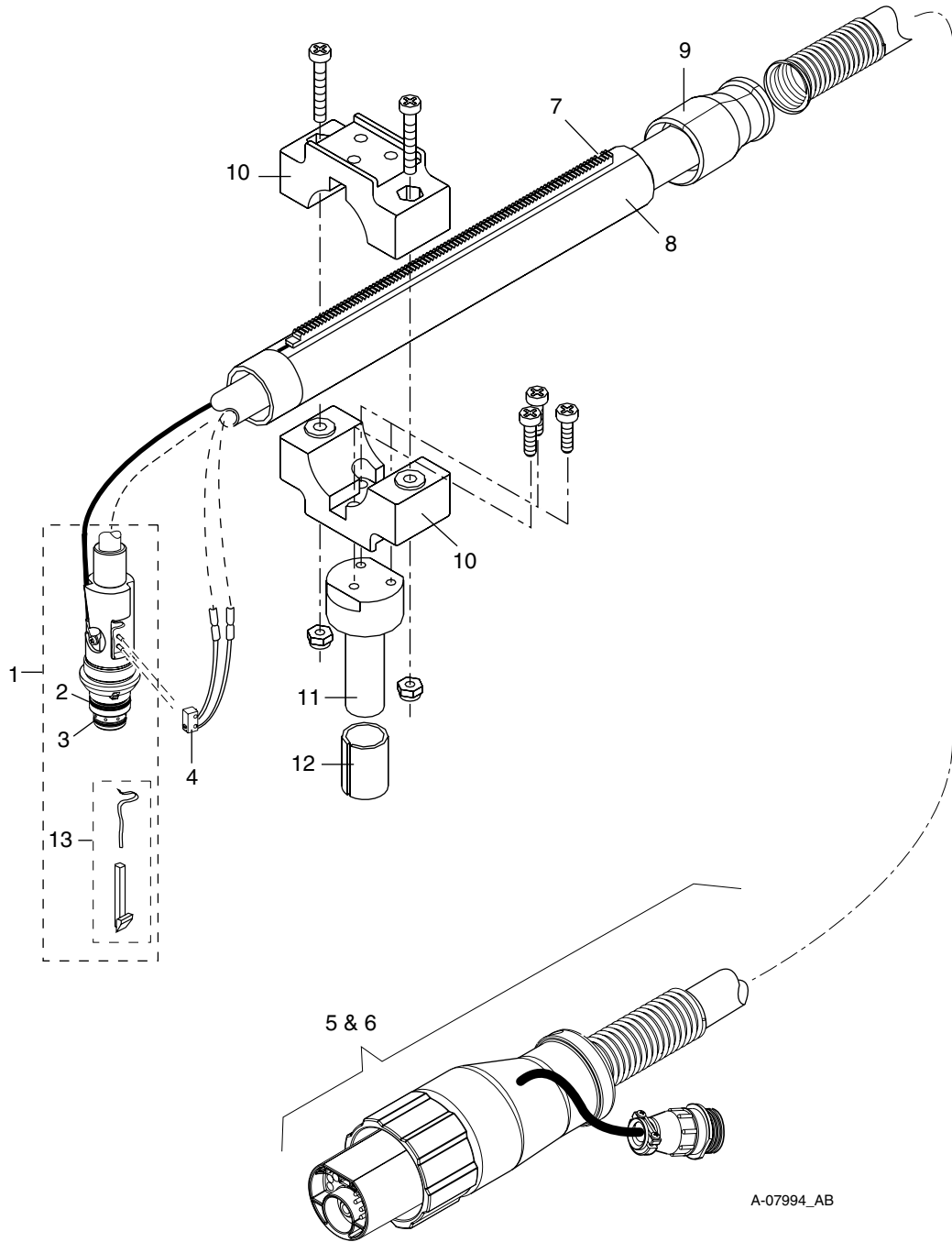

A-07994_AB

CUTMASTER 20mm

6.08 Replacement Shielded Machine Torch Leads Assemblies

| Item No. | Qty | Description | Catalog No. |
|----------|-----|--|-------------|
| 1 | | Mechanized Shielded Leads Assemblies with ATC Connectors | |
| 1 | | 5 - foot / 1.5 m Leads Assembly with ATC Connector | 4-7846 |
| 1 | | 10 - foot / 3.05 m Leads Assembly with ATC Connector | 4-7847 |
| 1 | | 25 - foot / 7.6 m Leads Assembly with ATC Connector | 4-7848 |
| 1 | | 50 - foot / 15.2 m Leads Assembly with ATC Connector | 4-7849 |

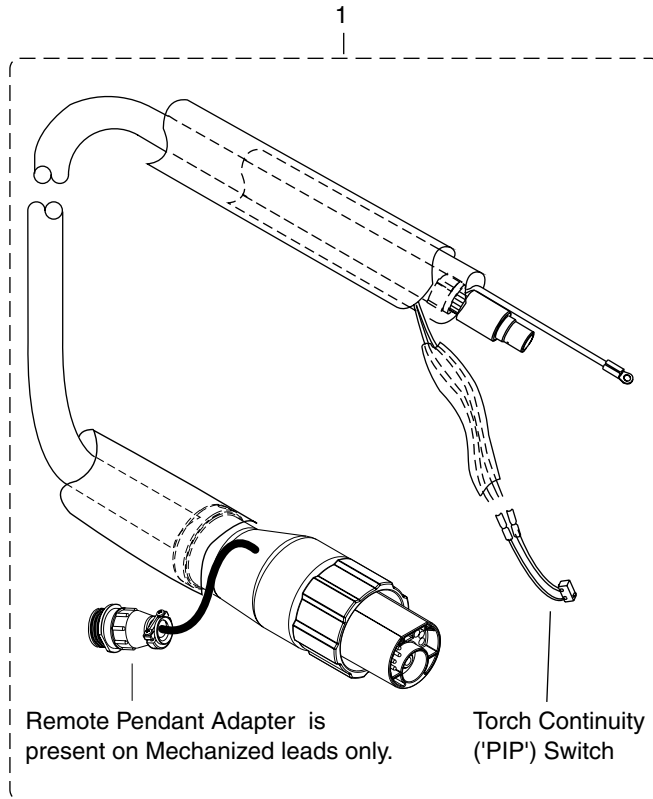

A-03684

6.09 Torch Consumable Parts (SL60)

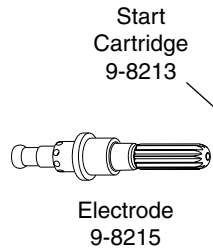
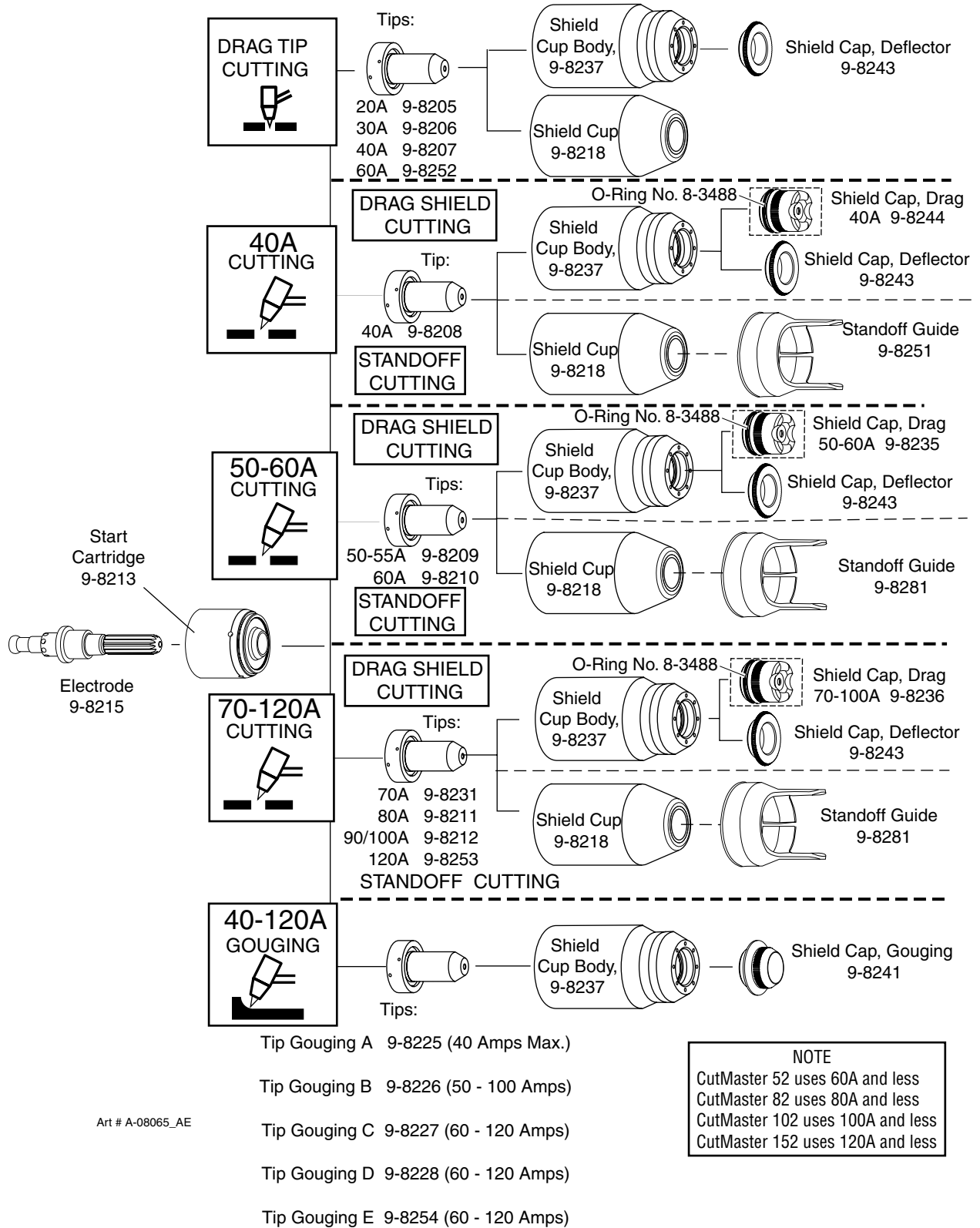

NOTE
 CutMaster 52 uses 60A and less
 CutMaster 82 uses 80A and less
 CutMaster 102 uses 100A and less
 CutMaster 152 uses 120A and less

Art # A-08065_AE

CUTMASTER 20mm

6.10 Torch Consumable Parts (SL100)

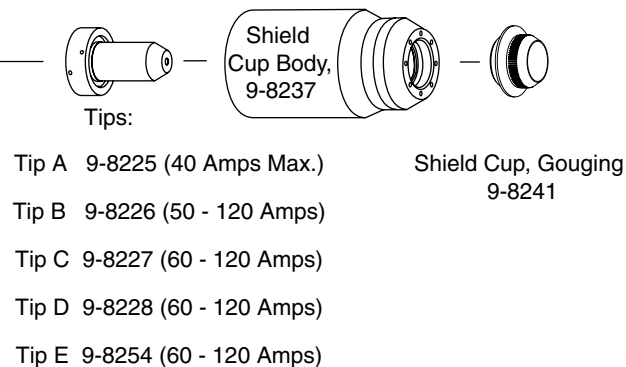
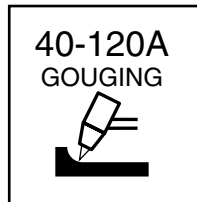
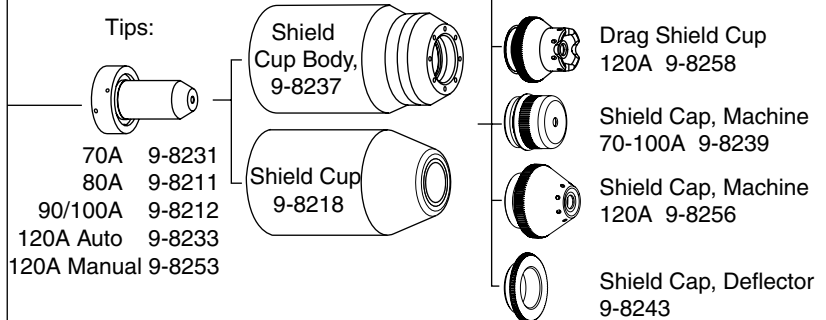
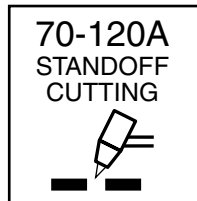
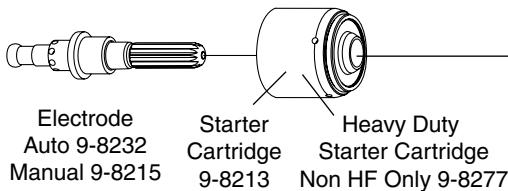
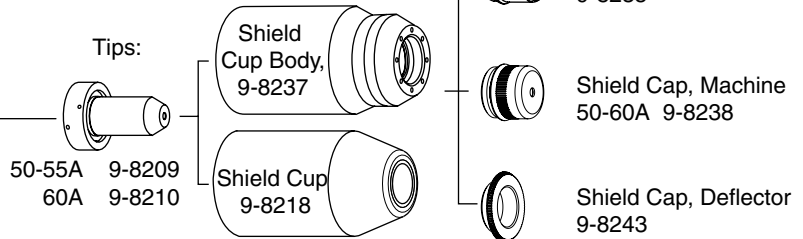
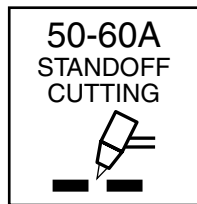
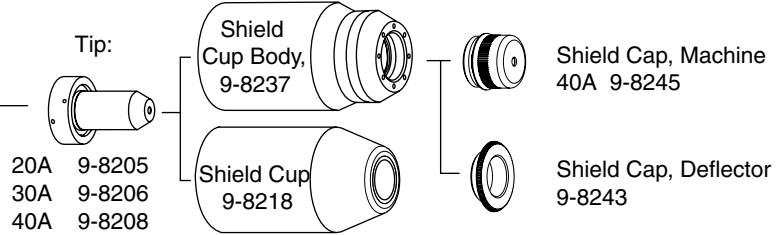
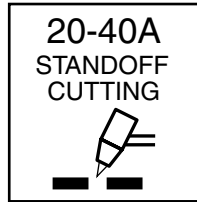
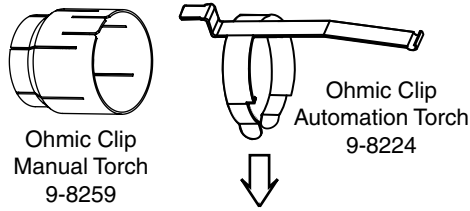

Art # A-08066_AG

This Page Intentionally Blank

This Page Intentionally Blank

APPENDIX 1: SEQUENCE OF OPERATION (BLOCK DIAGRAM)

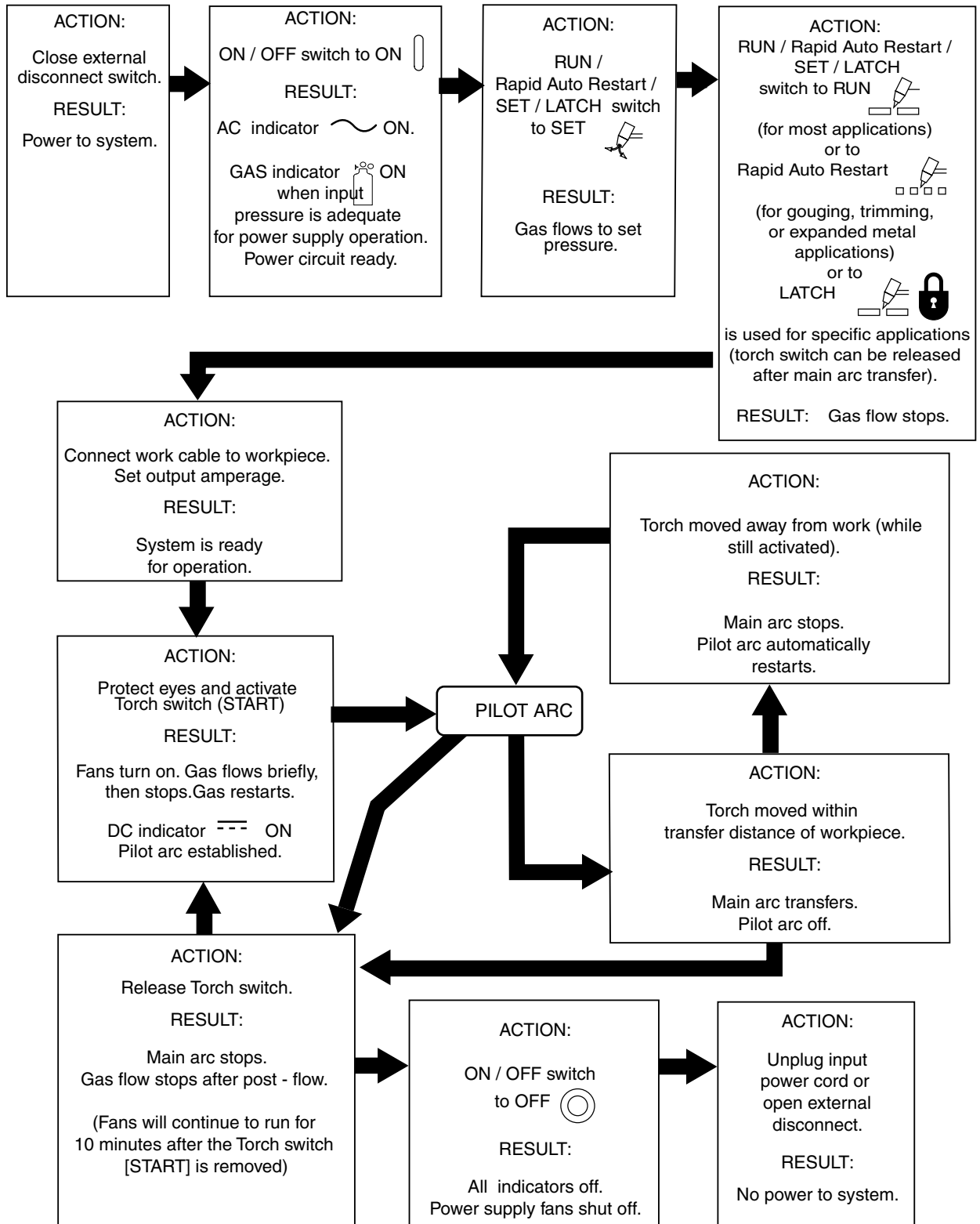

Art #A-07979_AB

APPENDIX 2: DATA TAG INFORMATION

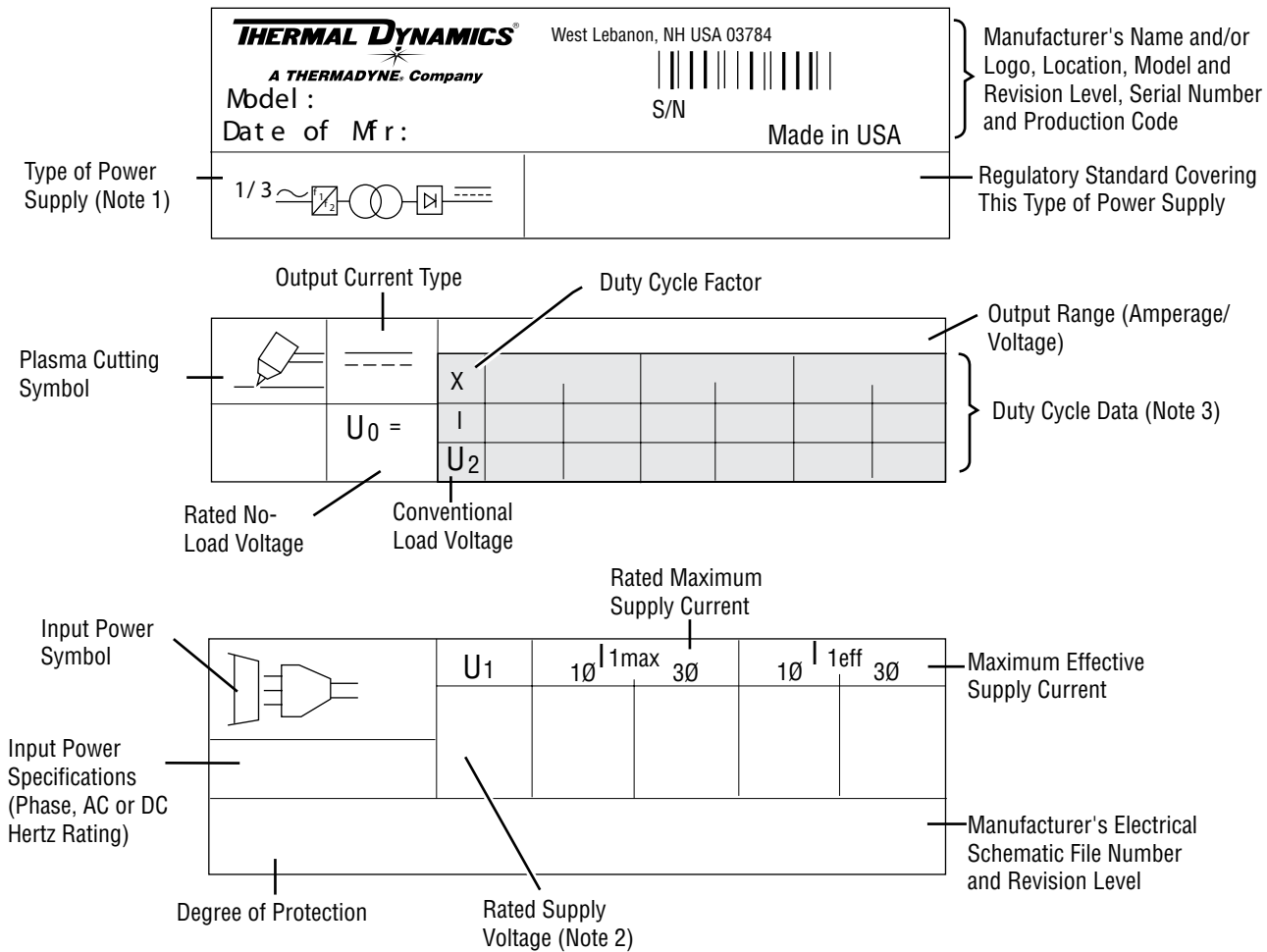

NOTES:

- Symbol shown indicates single- or three-phase AC input, static frequency converter-transformer-rectifier, DC output.
- Indicates input voltages for this power supply. Most power supplies carry a label at the input power cord showing input voltage requirements for the power supply as built.
- Top row: Duty cycle values.
IEC duty cycle value is calculated as specified by the International ElectroTechnical Commission.
TDC duty cycle value is determined under the power supply manufacturer's test procedures.
Second row: Rated cutting current values.
Third row: Conventional load voltage values.
- Sections of the Data Tag may be applied to separate areas of the power supply.

Standard Symbols

- ~ AC
- DC
- Ø Phase

Art # A-03288

APPENDIX 3: TORCH PIN - OUT DIAGRAMS

A. Hand Torch Pin - Out Diagram

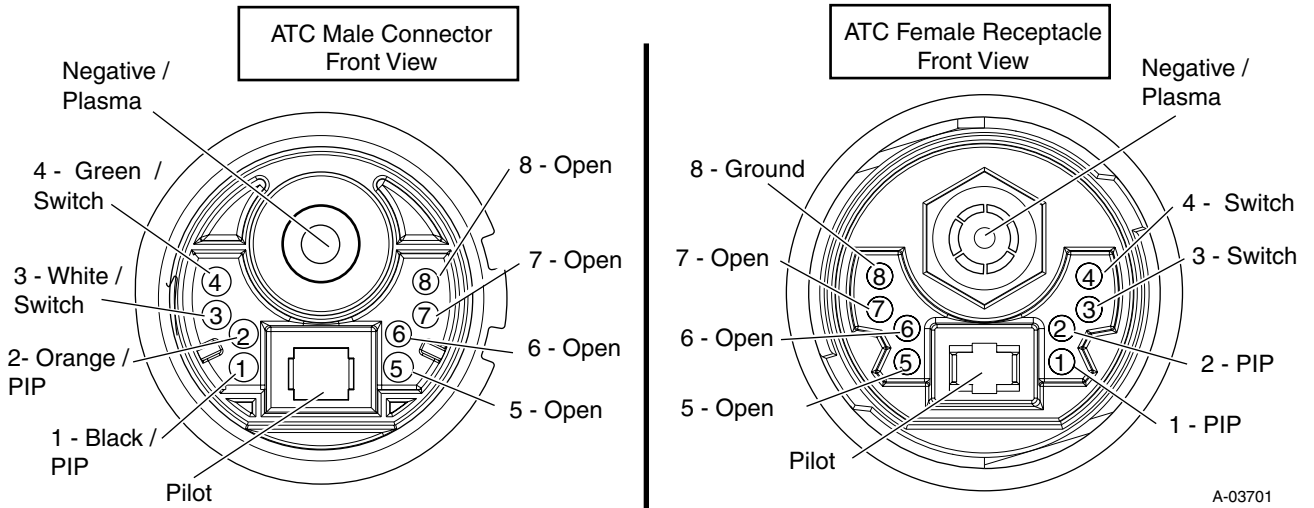

B. Mechanized (Machine) Torch Pin - Out Diagram

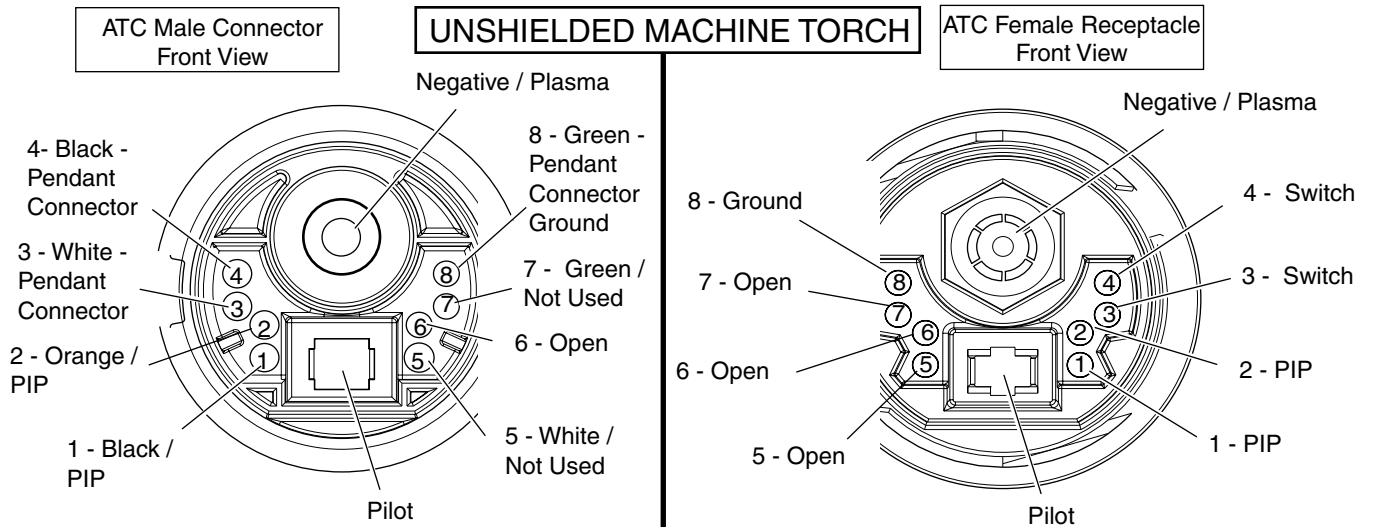

Art # A-03799

APPENDIX 4: TORCH CONNECTION DIAGRAMS

A. Hand Torch Connection Diagram

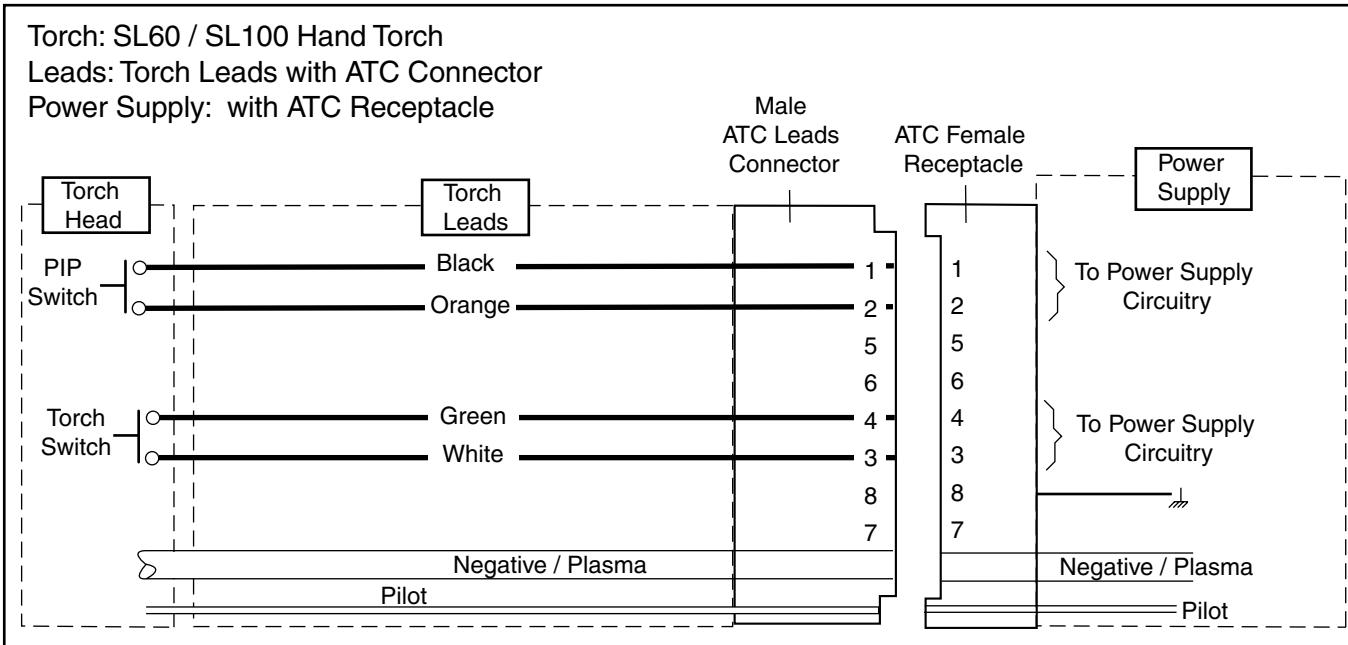

Art # A-03797

B. Mechanized Torch Connection Diagram

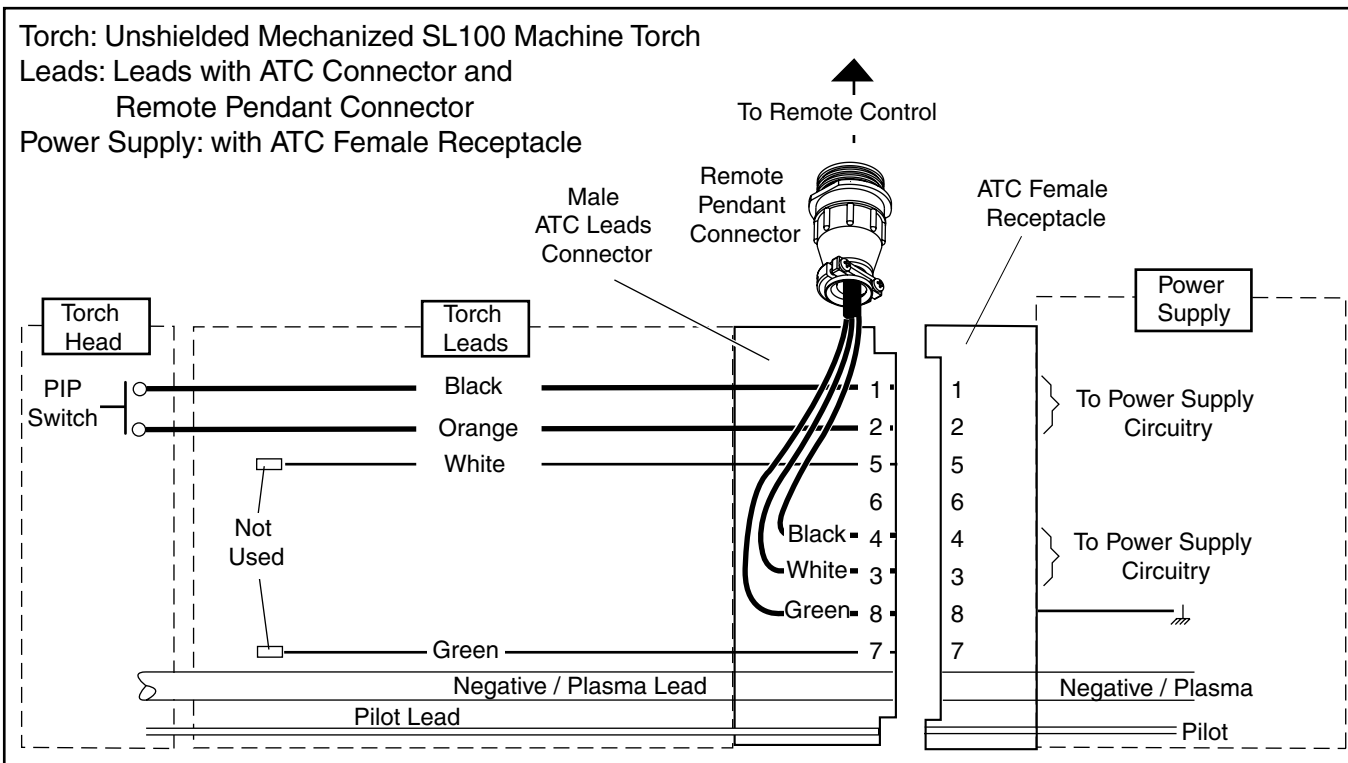

Art # A-03798

This Page Intentionally Blank

APPENDIX 5: SYSTEM SCHEMATIC, 380/400/415V UNITS

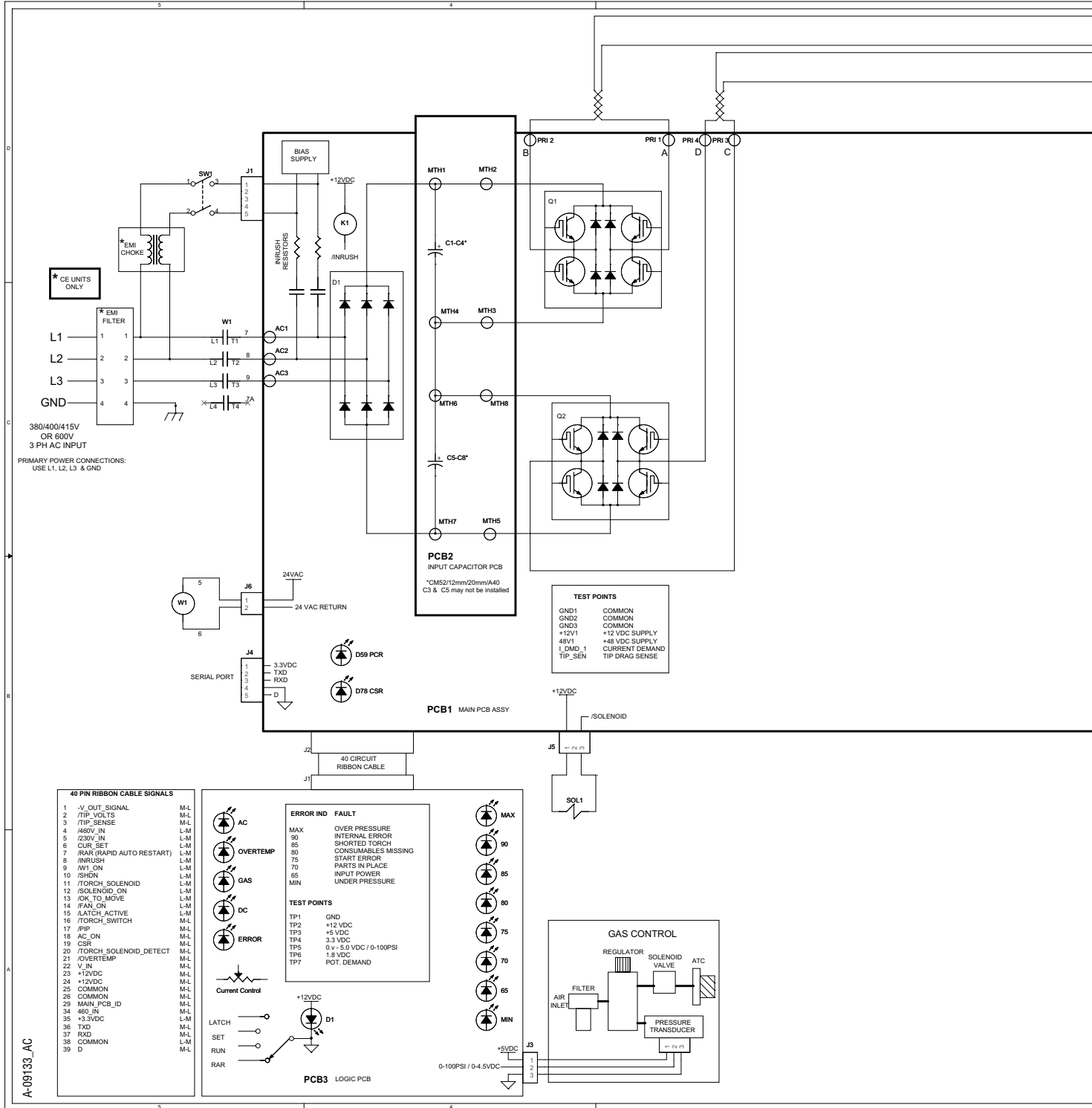

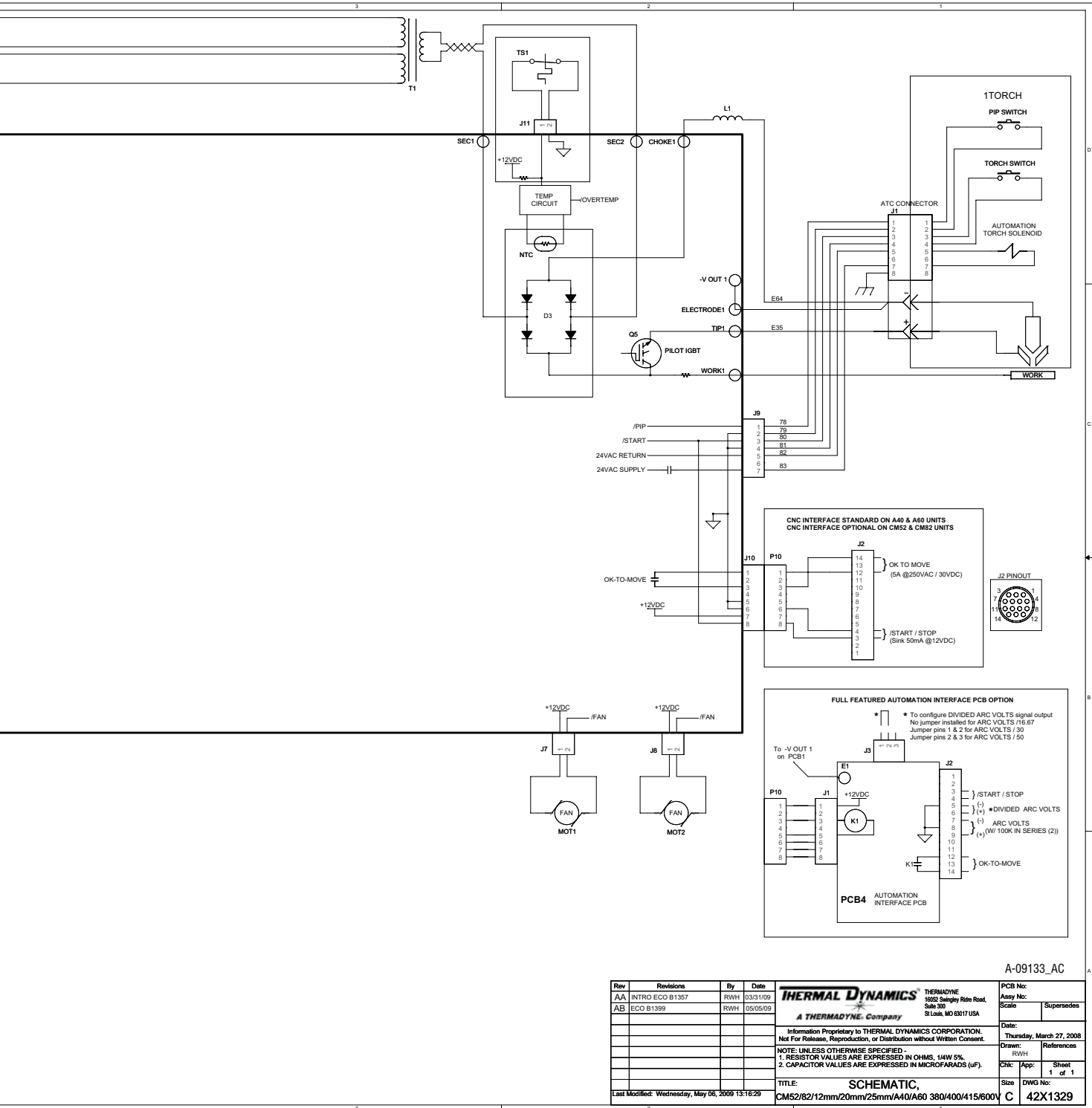

APPENDIX 6: Publication History

| Cover Date | Rev.Change(s) | |
|-------------------|----------------------|--|
| Sept. 18, 2008 | AA | Manual released. |
| May 27, 2009 | AB | Updated 400V/600V schematic in appendix per ECOB1399 |
| Feb. 25,2010 | AC | Updated CNC cable part numbers in section 6 per ECOB1637. |
| Sept. 14, 2010 | AD | Updated SL-100 consumables art in section 6 per ECOB1819. |
| Feb. 8, 2011 | AE | Per ECOB1859 corrected Schematics with art number A-09131 and A-09133 to show proper ARC Volts for Automation Interface PCB. |
| Mar. 20, 2012 | AF | Updated ART A-08066 and changed COO text, per ECOB2149. |
| 3/26/12 | AG | Updated CAP PCB catalog number page 6-5 per ECOB1502. |
| April 25, 2012 | AH | Updated ART A-07994 per ECOB2136. |

This Page Intentionally Blank

Printed in: Mexico

**U.S. Customer Care: 800-426-1888 / FAX 800-535-0557 • Canada Customer Care: 905-827-4515 / FAX 800-588-1714
International Customer Care: 940-381-1212 / FAX 940-483-8178 • www.thermal-dynamics.com**



A Global Cutting & Welding Market Leader™

THE AMERICAS

**Denton, TX USA
U.S. Customer Care**
Ph: 1-800-426-1888 (tollfree)
Fax: 1-800-535-0557 (tollfree)
International Customer Care
Ph: 1-940-381-1212
Fax: 1-940-483-8178

**Miami, FL USA
Sales Office, Latin America**
Ph: 1-954-727-8371
Fax: 1-954-727-8376

**Oakville, Ontario, Canada
Canada Customer Care**
Ph: 1-905-827-4515
Fax: 1-800-588-1714 (tollfree)

EUROPE

**Chorley, United Kingdom
Customer Care**
Ph: +44 1257-261755
Fax: +44 1257-224800

**Milan, Italy
Customer Care**
Ph: +39 0236546801
Fax: +39 0236546840

ASIA/PACIFIC

**Cikarang, Indonesia
Customer Care**
Ph: 6221-8990-6095
Fax: 6221-8990-6096

**Rawang, Malaysia
Customer Care**
Ph: +603 6092-2988
Fax: +603 6092-1085

**Melbourne, Australia
Australia Customer Care**
Ph: 1300-654-674 (tollfree)
Ph: 61-3-9474-7400
Fax: 61-3-9474-7391
International
Ph: 61-3-9474-7508
Fax: 61-3-9474-7484

**Shanghai, China
Sales Office**
Ph: +86 21-64072626
Fax: +86 21-64483032

**Singapore
Sales Office**
Ph: +65 6832-8066
Fax: +65 6763-5812