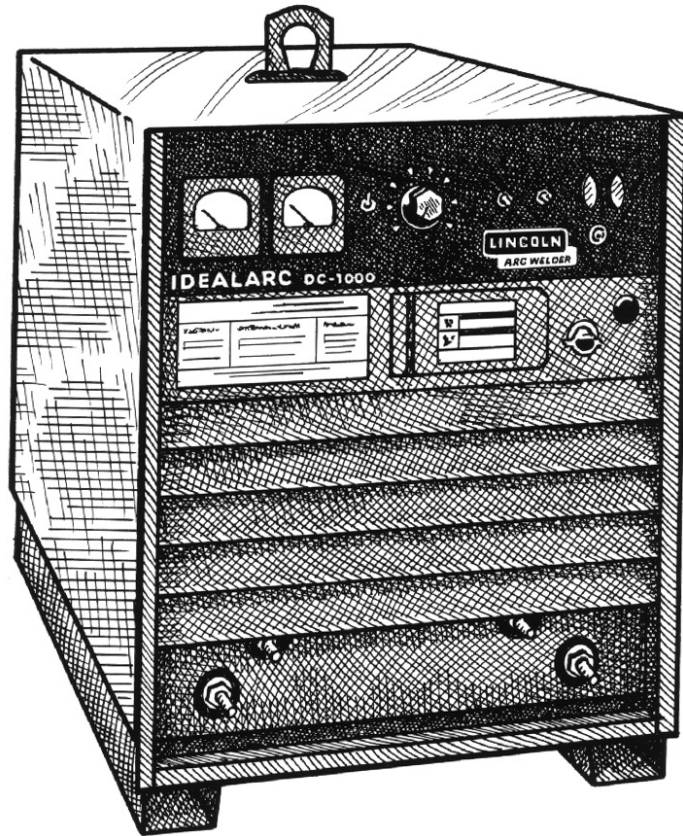

IDEALARC® DC-1000

For use with machines having Code Numbers:

§9919 - 9925, 10293, 11305, 11330, 11331, 11332, 11333,
11334, 11681 thru 11684**Safety Depends on You**

Lincoln arc welding and cutting equipment is designed and built with safety in mind. However, your overall safety can be increased by proper installation ... and thoughtful operation on your part. **DO NOT INSTALL, OPERATE OR REPAIR THIS EQUIPMENT WITHOUT READING THIS MANUAL AND THE SAFETY PRECAUTIONS CONTAINED THROUGHOUT.** And, most importantly, think before you act and be careful.

**OPERATOR'S MANUAL****LINCOLN®
ELECTRIC**

Copyright © Lincoln Global Inc.

- World's Leader in Welding and Cutting Products •
- Sales and Service through Subsidiaries and Distributors Worldwide •

Cleveland, Ohio 44117-1199 U.S.A. TEL: 216.481.8100 FAX: 216.486.1751 WEB SITE: www.lincolnelectric.com

WARNING

CALIFORNIA PROPOSITION 65 WARNINGS

Diesel engine exhaust and some of its constituents are known to the State of California to cause cancer, birth defects, and other reproductive harm.

The Above For Diesel Engines

The engine exhaust from this product contains chemicals known to the State of California to cause cancer, birth defects, or other reproductive harm.

The Above For Gasoline Engines

ARC WELDING CAN BE HAZARDOUS. PROTECT YOURSELF AND OTHERS FROM POSSIBLE SERIOUS INJURY OR DEATH. KEEP CHILDREN AWAY. PACEMAKER WEARERS SHOULD CONSULT WITH THEIR DOCTOR BEFORE OPERATING.

Read and understand the following safety highlights. For additional safety information, it is strongly recommended that you purchase a copy of "Safety in Welding & Cutting - ANSI Standard Z49.1" from the American Welding Society, P.O. Box 351040, Miami, Florida 33135 or CSA Standard W117.2-1974. A Free copy of "Arc Welding Safety" booklet E205 is available from the Lincoln Electric Company, 22801 St. Clair Avenue, Cleveland, Ohio 44117-1199.

BE SURE THAT ALL INSTALLATION, OPERATION, MAINTENANCE AND REPAIR PROCEDURES ARE PERFORMED ONLY BY QUALIFIED INDIVIDUALS.



FOR ENGINE powered equipment.

1.a. Turn the engine off before troubleshooting and maintenance work unless the maintenance work requires it to be running.



1.b. Operate engines in open, well-ventilated areas or vent the engine exhaust fumes outdoors.



1.c. Do not add the fuel near an open flame welding arc or when the engine is running. Stop the engine and allow it to cool before refueling to prevent spilled fuel from vaporizing on contact with hot engine parts and igniting. Do not spill fuel when filling tank. If fuel is spilled, wipe it up and do not start engine until fumes have been eliminated.

1.d. Keep all equipment safety guards, covers and devices in position and in good repair. Keep hands, hair, clothing and tools away from V-belts, gears, fans and all other moving parts when starting, operating or repairing equipment.

1.e. In some cases it may be necessary to remove safety guards to perform required maintenance. Remove guards only when necessary and replace them when the maintenance requiring their removal is complete. Always use the greatest care when working near moving parts.



1.f. Do not put your hands near the engine fan. Do not attempt to override the governor or idler by pushing on the throttle control rods while the engine is running.

1.g. To prevent accidentally starting gasoline engines while turning the engine or welding generator during maintenance work, disconnect the spark plug wires, distributor cap or magneto wire as appropriate.



1.h. To avoid scalding, do not remove the radiator pressure cap when the engine is hot.



ELECTRIC AND MAGNETIC FIELDS may be dangerous

2.a. Electric current flowing through any conductor causes localized Electric and Magnetic Fields (EMF). Welding current creates EMF fields around welding cables and welding machines

2.b. EMF fields may interfere with some pacemakers, and welders having a pacemaker should consult their physician before welding.

2.c. Exposure to EMF fields in welding may have other health effects which are now not known.

2.d. All welders should use the following procedures in order to minimize exposure to EMF fields from the welding circuit:

2.d.1. Route the electrode and work cables together - Secure them with tape when possible.

2.d.2. Never coil the electrode lead around your body.

2.d.3. Do not place your body between the electrode and work cables. If the electrode cable is on your right side, the work cable should also be on your right side.

2.d.4. Connect the work cable to the workpiece as close as possible to the area being welded.

2.d.5. Do not work next to welding power source.

Mar '95



ELECTRIC SHOCK can kill.

3.a. The electrode and work (or ground) circuits are electrically "hot" when the welder is on. Do not touch these "hot" parts with your bare skin or wet clothing. Wear dry, hole-free gloves to insulate hands.

3.b. Insulate yourself from work and ground using dry insulation. Make certain the insulation is large enough to cover your full area of physical contact with work and ground.

In addition to the normal safety precautions, if welding must be performed under electrically hazardous conditions (in damp locations or while wearing wet clothing; on metal structures such as floors, gratings or scaffolds; when in cramped positions such as sitting, kneeling or lying, if there is a high risk of unavoidable or accidental contact with the workpiece or ground) use the following equipment:

- **Semiautomatic DC Constant Voltage (Wire) Welder.**
- **DC Manual (Stick) Welder.**
- **AC Welder with Reduced Voltage Control.**

3.c. In semiautomatic or automatic wire welding, the electrode, electrode reel, welding head, nozzle or semiautomatic welding gun are also electrically "hot".

3.d. Always be sure the work cable makes a good electrical connection with the metal being welded. The connection should be as close as possible to the area being welded.

3.e. Ground the work or metal to be welded to a good electrical (earth) ground.

3.f. Maintain the electrode holder, work clamp, welding cable and welding machine in good, safe operating condition. Replace damaged insulation.

3.g. Never dip the electrode in water for cooling.

3.h. Never simultaneously touch electrically "hot" parts of electrode holders connected to two welders because voltage between the two can be the total of the open circuit voltage of both welders.

3.i. When working above floor level, use a safety belt to protect yourself from a fall should you get a shock.

3.j. Also see Items 6.c. and 8.



ARC RAYS can burn.

4.a. Use a shield with the proper filter and cover plates to protect your eyes from sparks and the rays of the arc when welding or observing open arc welding. Headshield and filter lens should conform to ANSI Z87.1 standards.

4.b. Use suitable clothing made from durable flame-resistant material to protect your skin and that of your helpers from the arc rays.

4.c. Protect other nearby personnel with suitable, non-flammable screening and/or warn them not to watch the arc nor expose themselves to the arc rays or to hot spatter or metal.



FUMES AND GASES can be dangerous.

5.a. Welding may produce fumes and gases hazardous to health. Avoid breathing these fumes and gases. When welding, keep your head out of the fume. Use enough ventilation and/or exhaust at the arc to keep

fumes and gases away from the breathing zone. **When welding with electrodes which require special ventilation such as stainless or hard facing (see instructions on container or MSDS) or on lead or cadmium plated steel and other metals or coatings which produce highly toxic fumes, keep exposure as low as possible and within applicable OSHA PEL and ACGIH TLV limits using local exhaust or mechanical ventilation. In confined spaces or in some circumstances, outdoors, a respirator may be required. Additional precautions are also required when welding on galvanized steel.**

5. b. The operation of welding fume control equipment is affected by various factors including proper use and positioning of the equipment, maintenance of the equipment and the specific welding procedure and application involved. Worker exposure level should be checked upon installation and periodically thereafter to be certain it is within applicable OSHA PEL and ACGIH TLV limits.

5.c. Do not weld in locations near chlorinated hydrocarbon vapors coming from degreasing, cleaning or spraying operations. The heat and rays of the arc can react with solvent vapors to form phosgene, a highly toxic gas, and other irritating products.

5.d. Shielding gases used for arc welding can displace air and cause injury or death. Always use enough ventilation, especially in confined areas, to insure breathing air is safe.

5.e. Read and understand the manufacturer's instructions for this equipment and the consumables to be used, including the material safety data sheet (MSDS) and follow your employer's safety practices. MSDS forms are available from your welding distributor or from the manufacturer.

5.f. Also see item 1.b.

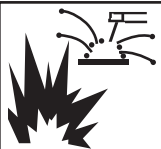

WELDING and CUTTING SPARKS can cause fire or explosion.

6.a. Remove fire hazards from the welding area. If this is not possible, cover them to prevent the welding sparks from starting a fire.

Remember that welding sparks and hot materials from welding can easily go through small cracks and openings to adjacent areas. Avoid welding near hydraulic lines. Have a fire extinguisher readily available.

6.b. Where compressed gases are to be used at the job site, special precautions should be used to prevent hazardous situations. Refer to "Safety in Welding and Cutting" (ANSI Standard Z49.1) and the operating information for the equipment being used.

6.c. When not welding, make certain no part of the electrode circuit is touching the work or ground. Accidental contact can cause overheating and create a fire hazard.

6.d. Do not heat, cut or weld tanks, drums or containers until the proper steps have been taken to insure that such procedures will not cause flammable or toxic vapors from substances inside. They can cause an explosion even though they have been "cleaned". For information, purchase "Recommended Safe Practices for the Preparation for Welding and Cutting of Containers and Piping That Have Held Hazardous Substances", AWS F4.1 from the American Welding Society (see address above).

6.e. Vent hollow castings or containers before heating, cutting or welding. They may explode.

6.f. Sparks and spatter are thrown from the welding arc. Wear oil free protective garments such as leather gloves, heavy shirt, cuffless trousers, high shoes and a cap over your hair. Wear ear plugs when welding out of position or in confined places. Always wear safety glasses with side shields when in a welding area.

6.g. Connect the work cable to the work as close to the welding area as practical. Work cables connected to the building framework or other locations away from the welding area increase the possibility of the welding current passing through lifting chains, crane cables or other alternate circuits. This can create fire hazards or overheat lifting chains or cables until they fail.

6.h. Also see item 1.c.

6.i. Read and follow NFPA 51B "Standard for Fire Prevention During Welding, Cutting and Other Hot Work", available from NFPA, 1 Batterymarch Park, PO box 9101, Quincy, Ma 022690-9101.

6.j. Do not use a welding power source for pipe thawing.



CYLINDER may explode if damaged.

7.a. Use only compressed gas cylinders containing the correct shielding gas for the process used and properly operating regulators designed for the gas and pressure used. All hoses, fittings, etc. should be suitable for the application and maintained in good condition.

7.b. Always keep cylinders in an upright position securely chained to an undercarriage or fixed support.

7.c. Cylinders should be located:

- Away from areas where they may be struck or subjected to physical damage.

- A safe distance from arc welding or cutting operations and any other source of heat, sparks, or flame.

7.d. Never allow the electrode, electrode holder or any other electrically "hot" parts to touch a cylinder.

7.e. Keep your head and face away from the cylinder valve outlet when opening the cylinder valve.

7.f. Valve protection caps should always be in place and hand tight except when the cylinder is in use or connected for use.

7.g. Read and follow the instructions on compressed gas cylinders, associated equipment, and CGA publication P-1, "Precautions for Safe Handling of Compressed Gases in Cylinders," available from the Compressed Gas Association 1235 Jefferson Davis Highway, Arlington, VA 22202.



FOR ELECTRICALLY powered equipment.

8.a. Turn off input power using the disconnect switch at the fuse box before working on the equipment.

8.b. Install equipment in accordance with the U.S. National Electrical Code, all local codes and the manufacturer's recommendations.

8.c. Ground the equipment in accordance with the U.S. National Electrical Code and the manufacturer's recommendations.

Refer to <http://www.lincolnelectric.com/safety> for additional safety information.

PRÉCAUTIONS DE SÛRETÉ

Pour votre propre protection lire et observer toutes les instructions et les précautions de sûreté spécifiques qui paraissent dans ce manuel aussi bien que les précautions de sûreté générales suivantes:

Sûreté Pour Soudage A L'Arc

1. Protégez-vous contre la secousse électrique:
 - a. Les circuits à l'électrode et à la pièce sont sous tension quand la machine à souder est en marche. Eviter toujours tout contact entre les parties sous tension et la peau nue ou les vêtements mouillés. Porter des gants secs et sans trous pour isoler les mains.
 - b. Faire très attention de bien s'isoler de la masse quand on soude dans des endroits humides, ou sur un plancher métallique ou des grilles métalliques, principalement dans les positions assis ou couché pour lesquelles une grande partie du corps peut être en contact avec la masse.
 - c. Maintenir le porte-électrode, la pince de masse, le câble de soudage et la machine à souder en bon et sûr état de fonctionnement.
 - d. Ne jamais plonger le porte-électrode dans l'eau pour le refroidir.
 - e. Ne jamais toucher simultanément les parties sous tension des porte-électrodes connectés à deux machines à souder parce que la tension entre les deux pinces peut être le total de la tension à vide des deux machines.
 - f. Si on utilise la machine à souder comme une source de courant pour soudage semi-automatique, ces précautions pour le porte-électrode s'appliquent aussi au pistolet de soudage.
2. Dans le cas de travail au dessus du niveau du sol, se protéger contre les chutes dans le cas où on reçoit un choc. Ne jamais enrouler le câble-électrode autour de n'importe quelle partie du corps.
3. Un coup d'arc peut être plus sévère qu'un coup de soleil, donc:
 - a. Utiliser un bon masque avec un verre filtrant approprié ainsi qu'un verre blanc afin de se protéger les yeux du rayonnement de l'arc et des projections quand on soude ou quand on regarde l'arc.
 - b. Porter des vêtements convenables afin de protéger la peau de soudeur et des aides contre le rayonnement de l'arc.
 - c. Protéger l'autre personnel travaillant à proximité au soudage à l'aide d'écrans appropriés et non-inflammables.
4. Des gouttes de laitier en fusion sont émises de l'arc de soudage. Se protéger avec des vêtements de protection libres de l'huile, tels que les gants en cuir, chemise épaisse, pantalons sans revers, et chaussures montantes.
5. Toujours porter des lunettes de sécurité dans la zone de soudage. Utiliser des lunettes avec écrans latéraux dans les zones où l'on pique le laitier.
6. Eloigner les matériaux inflammables ou les recouvrir afin de prévenir tout risque d'incendie dû aux étincelles.
7. Quand on ne soude pas, poser la pince à un endroit isolé de la masse. Un court-circuit accidentel peut provoquer un échauffement et un risque d'incendie.
8. S'assurer que la masse est connectée le plus près possible de la zone de travail qu'il est pratique de le faire. Si on place la masse sur la charpente de la construction ou d'autres endroits éloignés de la zone de travail, on augmente le risque de voir passer le courant de soudage par les chaînes de levage, câbles de grue, ou autres circuits. Cela peut provoquer des risques d'incendie ou d'échauffement des chaînes et des câbles jusqu'à ce qu'ils se rompent.
9. Assurer une ventilation suffisante dans la zone de soudage. Ceci est particulièrement important pour le soudage de tôles galvanisées plombées, ou cadmiées ou tout autre métal qui produit des fumées toxiques.
10. Ne pas souder en présence de vapeurs de chlore provenant d'opérations de dégraissage, nettoyage ou pistologie. La chaleur ou les rayons de l'arc peuvent réagir avec les vapeurs du solvant pour produire du phosgène (gas fortement toxique) ou autres produits irritants.
11. Pour obtenir de plus amples renseignements sur la sûreté, voir le code "Code for safety in welding and cutting" CSA Standard W 117.2-1974.

PRÉCAUTIONS DE SÛRETÉ POUR LES MACHINES À SOUDER À TRANSFORMATEUR ET À REDRESSEUR

1. Relier à la terre le châssis du poste conformément au code de l'électricité et aux recommandations du fabricant. Le dispositif de montage ou la pièce à souder doit être branché à une bonne mise à la terre.
2. Autant que possible, l'installation et l'entretien du poste seront effectués par un électricien qualifié.
3. Avant de faire des travaux à l'intérieur de poste, la débrancher à l'interrupteur à la boîte de fusibles.
4. Garder tous les couvercles et dispositifs de sûreté à leur place.

Thank You

for selecting a **QUALITY** product by Lincoln Electric. We want you to take pride in operating this Lincoln Electric Company product
••• as much pride as we have in bringing this product to you!

CUSTOMER ASSISTANCE POLICY

The business of The Lincoln Electric Company is manufacturing and selling high quality welding equipment, consumables, and cutting equipment. Our challenge is to meet the needs of our customers and to exceed their expectations. On occasion, purchasers may ask Lincoln Electric for advice or information about their use of our products. We respond to our customers based on the best information in our possession at that time. Lincoln Electric is not in a position to warrant or guarantee such advice, and assumes no liability, with respect to such information or advice. We expressly disclaim any warranty of any kind, including any warranty of fitness for any customer's particular purpose, with respect to such information or advice. As a matter of practical consideration, we also cannot assume any responsibility for updating or correcting any such information or advice once it has been given, nor does the provision of information or advice create, expand or alter any warranty with respect to the sale of our products.

Lincoln Electric is a responsive manufacturer, but the selection and use of specific products sold by Lincoln Electric is solely within the control of, and remains the sole responsibility of the customer. Many variables beyond the control of Lincoln Electric affect the results obtained in applying these types of fabrication methods and service requirements.

Subject to Change – This information is accurate to the best of our knowledge at the time of printing. Please refer to www.lincolnelectric.com for any updated information.

Please Examine Carton and Equipment For Damage Immediately

When this equipment is shipped, title passes to the purchaser upon receipt by the carrier. Consequently, Claims for material damaged in shipment must be made by the purchaser against the transportation company at the time the shipment is received.

Please record your equipment identification information below for future reference. This information can be found on your machine nameplate.

Product _____

Model Number _____

Code Number or Date Code _____

Serial Number _____

Date Purchased _____

Where Purchased _____

Whenever you request replacement parts or information on this equipment, always supply the information you have recorded above. The code number is especially important when identifying the correct replacement parts.

On-Line Product Registration

- Register your machine with Lincoln Electric either via fax or over the Internet.
 - For faxing: Complete the form on the back of the warranty statement included in the literature packet accompanying this machine and fax the form per the instructions printed on it.
 - For On-Line Registration: Go to our **WEB SITE at www.lincolnelectric.com**. Choose "Quick Links" and then "Product Registration". Please complete the form and submit your registration.

Read this Operators Manual completely before attempting to use this equipment. Save this manual and keep it handy for quick reference. Pay particular attention to the safety instructions we have provided for your protection. The level of seriousness to be applied to each is explained below:

WARNING

This statement appears where the information **must** be followed **exactly** to avoid **serious personal injury** or **loss of life**.

CAUTION

This statement appears where the information **must** be followed to avoid **minor personal injury** or **damage to this equipment**.

Installation	Section A
Technical Specifications	A-1
Safety Precautions	A-2
Location	A-2
Stacking	A-2
Input Wiring	A-2
Reconnect Procedures	A-3, A-4
Output Connections	A-5
<hr/>	
Operation	Section B
Safety Precautions	B-1
Product Description	B-1
To Set Polarity	B-2
Set-Up For Various Procedures.....	B-2, B-3
<hr/>	
Maintenance	Section D
Safety Precautions	D-1
General Maintenance	D-1
Overload Protection	D-1
<hr/>	
Troubleshooting	Section E
Safety Precautions.....	E-1
How to Use Troubleshooting Guide.....	E-1
Troubleshooting Guide.....	E-2 thru E-7
<hr/>	
Connection and Wiring Diagrams	Section F
<hr/>	
Parts List	P-146 Series

TECHNICAL SPECIFICATIONS – DC-1000

INPUT - THREE PHASE ONLY					
<u>Standard Voltage</u>		<u>Input Current at Rated Output</u>			
		<u>100% Duty Cycle</u>	<u>60% Duty Cycle</u>	<u>50% Duty Cycle</u>	
230/460/60		193/96.5	215/108	230/115	
575/60		77.2	86	92	
220/380/440/50/60		193/112/96.5	215/124/108	230/133/115	
380/500/50/60		112/85	124/94	133/101	
415/50/60		102	113	121	
RATED OUTPUT					
<u>Duty Cycle</u>		<u>Amps</u>	<u>Volts at Rated Amperes</u>		
100% Duty Cycle		1000	44		
60% Duty Cycle		1140	44		
50% Duty Cycle		1250	44		
OUTPUT					
<u>Output Range</u>		<u>Maximum Open Circuit Voltage</u>		<u>Auxiliary Power</u>	
150A/16V-1300A/46V		75V for 60 HZ models 72V for 50/60 HZ models		See the OPERATION section for Auxiliary Power information by model	
RECOMMENDED INPUT WIRE AND FUSE SIZES					
<u>INPUT VOLTAGE / FREQUENCY</u>	<u>HERTZ</u>	<u>INPUT AMPERE RATING ON NAMEPLATE</u>	<u>TYPE 75°C COPPER WIRE IN CONDUIT AWG(IEC-MM²) SIZES 30°C (86°F) Ambient</u>	<u>TYPE 75°C GROUND WIRE IN CONDUIT AWG(IEC-MM²) SIZES</u>	<u>TYPE 75°C (SUPER LAG) OR BREAKER SIZE (AMPS)¹</u>
230	60	193	000 (85)	4 (21)	300 Amp
460	60	96.5	3 (27)	6 (14)	150 Amp
575	60	77.2	4 (21)	6 (14)	125 Amp
220	50/60	193	000 (85)	4 (21)	300 Amp
380	50/60	112	2 (34)	6 (14)	175 Amp
415	50/60	102	2 (34)	6 (14)	150 Amp
440	50/60	96.5	3 (27)	6 (14)	150 Amp
500	50/60	85	4 (21)	6 (14)	125 Amp
PHYSICAL DIMENSIONS					
<u>HEIGHT</u>	<u>WIDTH</u>	<u>DEPTH</u>	<u>WEIGHT</u>		
30.75 in 781 mm	22.25 in 567 mm	39.0 in 991 mm	821 lbs. 372 kg.		

¹Also called "inverse time" or "thermal/magnetic" circuit breakers; circuit breakers which have a delay in tripping action that decreases as the magnitude of the current increases.

SAFETY PRECAUTIONS

Read this entire installation section before you start installation.

⚠ WARNING



ELECTRIC SHOCK can kill.

- Only qualified personnel should perform this installation.
- Turn the input power OFF at the disconnect switch or fuse box before working on this equipment. Turn off the input power to any other equipment connected to the welding system at the disconnect switch or fuse box before working on the equipment.
- Do not touch electrically hot parts.
- Always connect the Power Wave grounding lug (located inside the reconnect input access door) to a proper safety (Earth) ground.

LOCATION

Even though the machine is designed to operate under a wide variety of environmental conditions, for maximum reliability and long life the machine should be located in a clean, dry place where there is free circulation of clean air in through the front and out the back of the machine. Dirt and dust that can be drawn into the machine should be kept to a minimum. Failure to observe these precautions can result in excessive operating temperatures and nuisance shutdown of the machine.

The case front incorporates a recessed control panel which protects the controls and minimizes the possibilities of accidental contact. This cover panel can be flipped open to permit access to the enclosed control section.

The individual case sides are removable for easy access for internal service or inspection.

The case rear is equipped with a removable cover plate, permitting easy access to the input panel.

The total enclosure, designed to permit outdoor operation, resists dust, salt, rain, humidity, and high and low temperature extremes.

The machine uses a 38" (965mm) long base. The low profile case facilitates installation of the machine under a workbench and stacking the machines two high to conserve floor space.

A permanent lifting eye is located at the top of the machine and is positioned so that it acts as nearly as possible through the center of gravity. This lift eye fits under the case of the second machine without interference when stacking.

STACKING

⚠ WARNING



FALLING EQUIPMENT can cause injury.

- Do not lift this machine using lift bale if it is equipped with a heavy accessory such as trailer or gas cylinder.
- Lift only with equipment of adequate lifting capacity.
- Be sure machine is stable when lifting.
- Do not stack more than two high.
- Do not stack the DC-1000 on top of any other machine.

Two DC-1000's may be stacked by observing the following safety precautions:

1. Make sure the first or bottom unit is setting on a level, well-supported surface.
2. The units must be stacked with their fronts flush, making sure the two holes in the base rails of the top unit are over the two pins located on top of the bottom unit.

INPUT WIRING

Be sure the voltage, phase and frequency of the input power is as specified on the welder nameplate.

Dual voltage (e.g. 230/460) models are shipped connected for the highest voltage. To change the connection, see the connection diagram pasted to the inside of the access panel in the case back.

Have a qualified electrician remove the rear access panel and connect 3 phase AC power to terminals L₁, L₂ and L₃ of the input panel in accordance with the U.S. National Electrical Code, all local codes and the wiring diagram located inside the machine.

The welder frame must be grounded. A stud marked with the symbol  located inside the machine near the input panel is provided for this purpose. See the U.S. National Electrical Code for details on proper grounding methods. (See Technical Specifications)

RECONNECT PROCEDURE

Multiple voltage machines are shipped connected to the highest input voltage listed on the machine's rating plate. Before installing the machine, check that the Reconnect Panel in the Input Box Assembly is connected for the proper voltage.

⚠ CAUTION

Failure to follow these instructions can cause immediate failure of components within the machine.

When powering welder from a generator be sure to turn off welder first, before generator is shut down, in order to prevent damage to the welder.

To reconnect a multiple voltage machine to a different voltage, remove input power and change the position of the reconnect board on the Reconnect Panel. Follow The Input Connection Diagram located on the inside of Case Back Input Access Door. These connection diagrams for the following codes are listed below.

1. For Single and Dual Voltage except 380/500 see Figure 1, (S17172).
2. For 220/380/460, see Figure 2, (M14358).
3. For 380/500, see Figure 3, (S17344).
4. For Voltages not listed, see the Input Connection Diagram pasted on the inside of the Case Back Input Access Door.

FIGURE 1

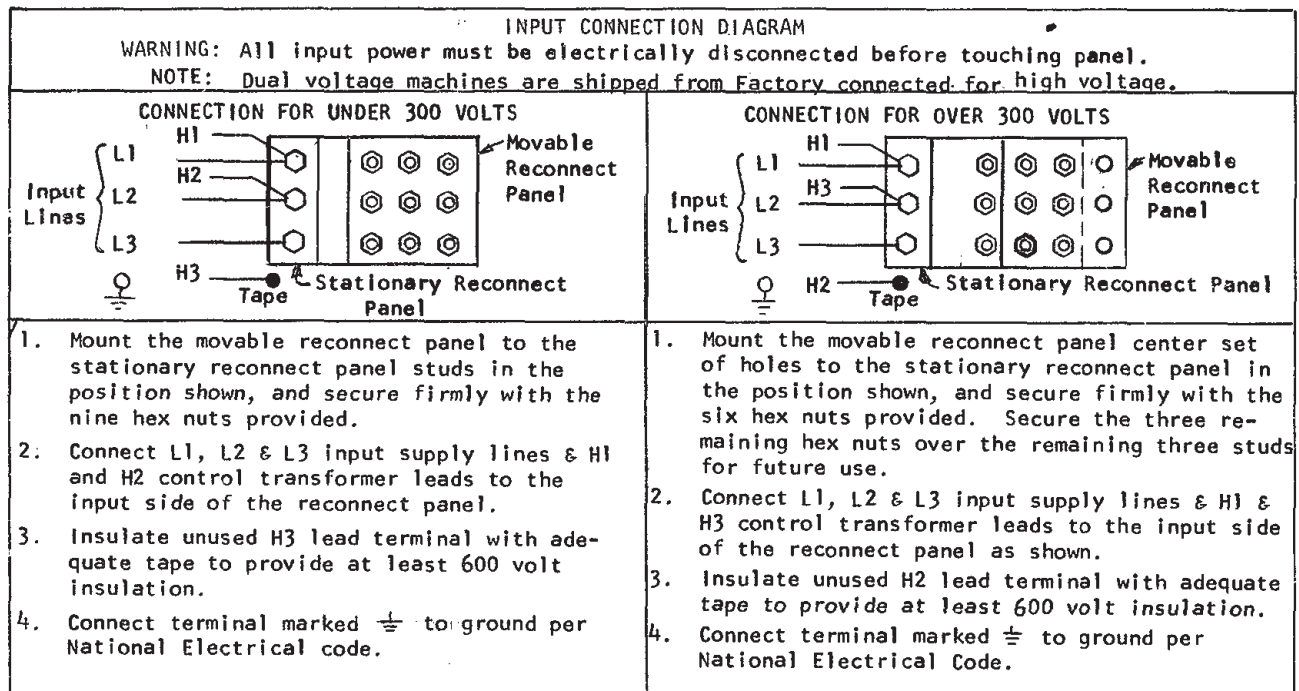

S-17172

FIGURE 2

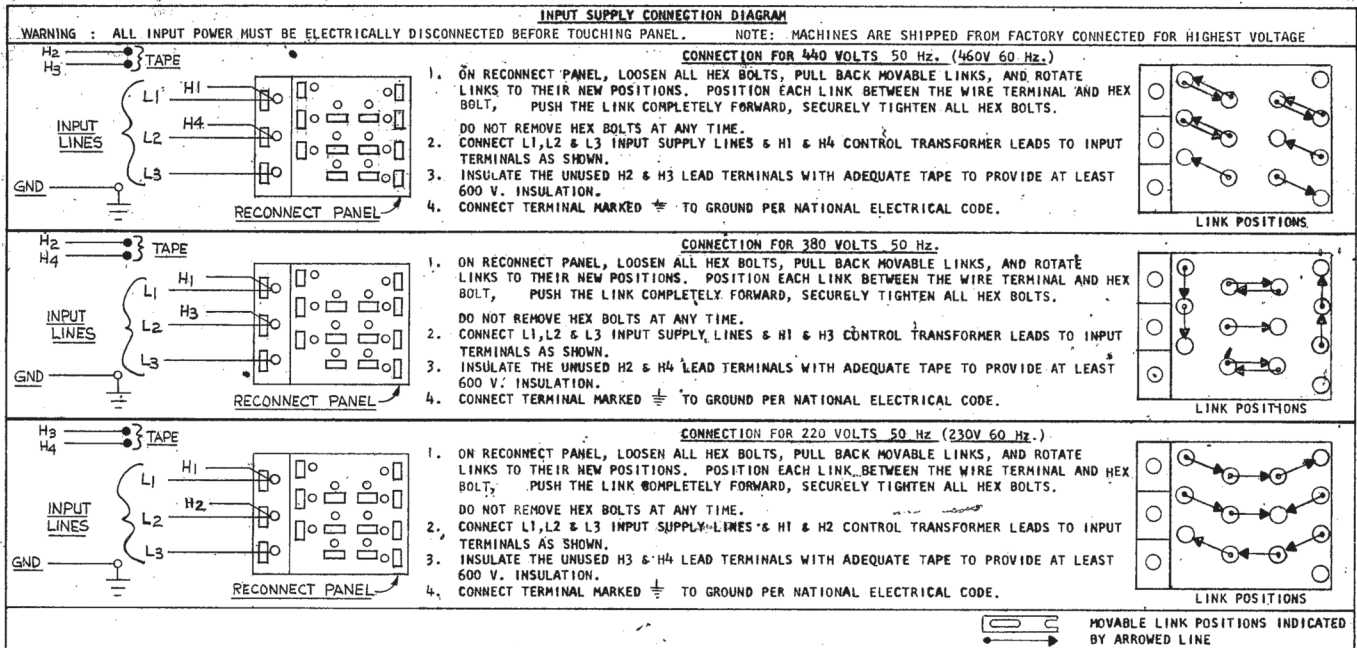

M-14358

FIGURE 3

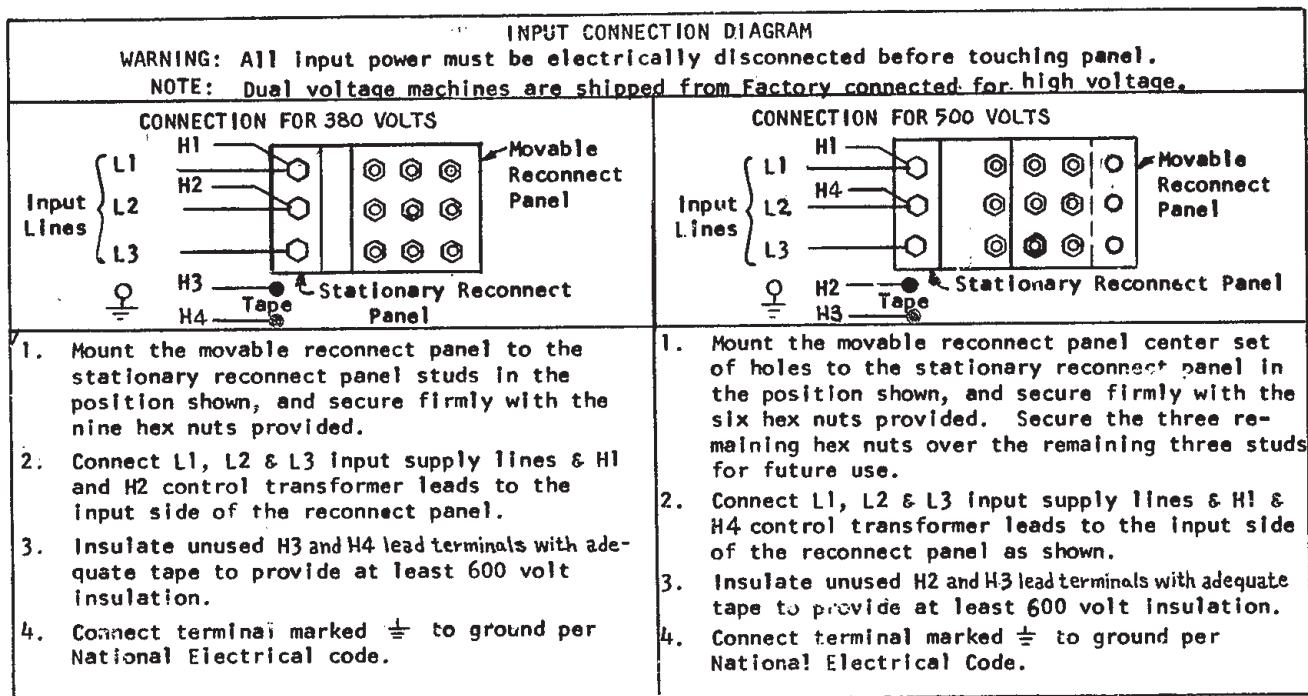

S-17344

OUTPUT CONNECTIONS

Output Studs

The output leads are connected to the output terminals. The output terminals are located on the lower case front and labeled “+” and “-”. There are 1000 amp rated “+” terminals on the right side, one 500 amp rated “+” terminal near the center and “-” terminals on the left side. They are fully recessed to minimize the possibility of accidental contact by an object or a person. Strain relief is provided by the oval holes in the base. The leads are run through these oval holes before they are connected to the output terminals.

The 1000 amp output connections provide the full rated output range of the machine. See Table 1 for recommended DC-1000 cable sizes for combined lengths of electrode and work cables.

The 500 amp output connections provide enhanced lower current arc characteristics, especially for submerged arc and GMAW procedures below 450 amps.

Auxiliary Power

This machine supplies the 115 volt, AC power needed for operating wire feeding equipment. The power is available from terminals #31 and #32 on the terminal strip. An 8 amp slow blow fuse on the machine control panel protects the auxiliary power from excessive overloads. The circuit has a 1000 volt-ampere rating.

Control Cable Connection

Terminal strips with screw connections are located behind the hinged door on the front of the power source to make all the control cable connections for operating wire feeding equipment. See the appropriate connection diagram for exact instructions covering the wire feeder being used.

With the DC-1000 turned off, the control cable from the automatic wire feeding equipment is connected to the terminal strip. A strain relief box connector is provided for access into the terminal strip section. A chassis grounding screw is also provided below the terminal strip marked with the symbol  for connecting the wire feeding equipment grounding wire. See the appropriate connection diagram for the exact instructions for the wire feeder being used. A spare hole is provided for an additional box connector if required.

Connecting for Air Carbon Arc:

- Turn off all power.
- Disconnect all wire feed unit control, electrode and work leads.
- Connect a jumper from 2-4 on terminal strip.
- Place mode switch in the CV(I) position.

With the DC-1000 connected for air carbon arc welding, the output terminals will be energized at all times.

TABLE 1
DC-1000 Cable Sizes for Combined Lengths of Copper Electrode and Work Cable
at 100% Duty Cycle

ELECTRODE, WORK AND #21 LEAD

Cable Length	Parallel Cables	Cable Size
Lengths up to 150 ft. (46m)	3	1/0 (53mm ²)
150 ft.(46m) to 200 ft (61m)	3	2/0 (67mm ²)
200 ft.(61m) to 250 ft.(76m)	3	3/0 (85mm ²)

IDEALARC® DC-1000



OPERATING INSTRUCTIONS

WARNING



- ELECTRIC SHOCK can kill.**
- Do not touch electrically live parts or electrode with skin or wet clothing.
 - Insulate yourself from work and ground.
 - Always wear dry insulating gloves.



- FUMES AND GASES can be dangerous.**
- Keep your head out of fumes.
 - Use ventilation or exhaust to remove fumes from breathing zone.



- WELDING SPARKS can cause fire or explosion.**
- Keep flammable material away.
 - Do not weld on closed containers.



- ARC RAYS can burn eyes and skin.**
- Wear eye, ear and body protection.

See additional warning information at front of this operator's manual.

PRODUCT DESCRIPTION

The DC-1000 is an SCR-controlled three phase DC power source. It is designed with a single range potentiometer control for submerged arc or open arc automatic and semiautomatic welding. It can be used for air carbon arc cutting with carbon rods up to and including 5/8" (15.9mm) dia. The DC-1000 (below code 9500) is *not* recommended for stick welding or for solid wire and gas in the short arc welding mode. With the addition of the 500 amp output stud to DC-1000 models above code 9500, GMAW procedures can be performed. This connection provides the enhanced lower current arc characteristics required for this type of welding.

The DC-1000 is provided with a three position mode switch that selects CV Innershield®, CV Submerged Arc or CC (Variable Voltage) Submerged Arc.

The unit is designed to be used with the NA-5, NA-5R and NA-3 automatics, the LT-56 and LT-7 tractors, and can also be used with the LN-7, LN-8 or LN-9 semiautomatic wire feeders.

NOTE: All P.C. boards are protected by a moisture resistant coating. When the welder is operated, this coating will "bake off" of certain power resistors that normally operate at high temperatures emitting some smoke and odor for a short time. These resistors and the P.C. board beneath them may become blackened. This is a normal occurrence and does not damage the component or affect the machine performance.

TO SET POLARITY

Turn off the DC-1000 and connect the electrode cable to the "Positive" or "Negative" studs depending upon the electrode polarity desired. Connect the work cable to the other stud. (See "Output Connections").

Set the "Electrode Negative-Electrode Positive" switch to correspond to the polarity of the electrode cable connection. This switch setting is necessary for proper operation of some Lincoln wire feeders and does not change the welding polarity.

Starting the Machine - The push button power "on" switch at the extreme right side of the control panel energizes and closes the three phase input contactor from a 115 volt auxiliary transformer. This in turn energizes the main power transformer.

The red light below the stop-start button indicates when the input contactor is energized.

Output Control - The output control in the center of the control panel is a continuous control of the machine output. The control may be rotated from min. to max. while under load to adjust the machine output.

The machine is equipped with line voltage compensation as a standard feature. This will hold the output relatively constant except at maximum output of the machine, through a fluctuation of +/- 10% of input line voltage.

Output Control at DC-1000 or Output Control Remote Switch

The toggle switch on the control panel labeled "Output Control at DC-1000" / "Output Control Remote" gives the operator the option of controlling the output at the machine control panel or at a remote station. For remote control, the toggle switch is set in the "Output Control Remote" position and controlled at the wire feed unit control or by connecting a K775 control to the appropriate terminals (as indicated on the connection diagram) on the terminal strip at the front of the machine. For control at the machine control panel, the toggle switch is set in the "Output Control at DC-1000" position.

Remote Output Control - (Optional)

The K775 Remote Output Control consists of a control box with 28 ft. (8.4m) of four conductor cable. This connects to terminals 75, 76, 77 on the terminal strip, and the case grounding screw so marked with the symbol  on the machine. These terminals are made available by opening the terminal access cover on the left side of the case front. This control will give the same control as the output control on the machine.

Mode Switch

The toggle switch labeled C (I) Innershield, CV(S) Submerged Arc, CC (or Variable Voltage) is used to select the proper welder characteristics for the process being used. The CC (or Variable Voltage) mode is primarily available for use with older wire feeding equipment such as the LAF-3, LT-34 and so forth. Use of this type of older equipment requires the addition of an NL Option Kit.

SET-UP FOR VARIOUS PROCEDURES

1. **Selection of mode switch position** - There are several general rules to follow in the selection of the mode switch position.
 - a. Use the CV(I) mode for all FCAW and GMAW processes. The CV(I) mode is also used for air carbon arc using carbon rods up to and including 5/8" (15.9mm) dia.

Welding with NR®-151, 202, 203 and other electrodes below 20 volts, is not recommended.
 - b. Use the CV(S) mode for all submerged arc welding. This applies to both low and high travel speeds.
 - c. The CC (Variable Voltage) mode is available for high current large puddle submerged arc procedures that cannot be done as well with the constant voltage mode. CC mode should be used for 3/16" (4.8mm) diameter electrode and above where high current surges cause machine shutdown when starting. This occurs primarily when the slag ball is not cut from the electrode prior to starting. (Also requires a wire feeder that has a constant current mode - i.e. NA-3S).

NOTE: Some processes and procedures may be better with the mode switch in the other CV position. If the mode switch position initially selected is not producing the desired results, then place the mode switch in the other CV position and make a test weld. Then use the CV mode switch position that gives the desired results.

2. **NA-3** - The NA-3 should be set for the mode being used on the power source. If using either of the CV modes, the NA-3 CC board switch should be set for CV. If the power source is used in the CC mode, then the NA-3 CC board mode switch should be placed in the CC position.

All the NA-3's when used with the DC-1000 are capable of cold starting with the constant current board mode switch in CC. Cold starting permits the wire to be inched down to the work, automatically stop, and automatically energize the flux hopper valve. All NA-3's made after September, 1976 are capable of cold starting on either CV or CC settings of the constant current board.

On the NA-3, set the open circuit voltage control to the same dial setting as the arc voltage control. If the procedure has not yet been established, a good starting point is to set the OCV to #6.

Run a test weld, setting the proper current, voltage and travel speed. Once the proper welding procedure is established and if the start is poor - wire blast off, stub, etc. - adjust the NA-3 OCV and inch speed controls for optimum starting. In general, a low inch speed and an OCV dial setting identical to the voltage dial setting will provide the best starting.

To further optimize starting, adjust the OCV by making repeated starts and observing the NA-3 voltmeter action. With proper adjustment of the OCV control, the voltmeter needle will swing smoothly up to the desired arc voltage and thus provide repeatable starts.

If the voltmeter swings *above* the set voltage and then back to the desired welding voltage, the OCV setting is *too high*. This usually results in a bad start where the wire tends to "blast off".

If the voltmeter needle hesitates *before* coming up to the desired voltage, the OCV is set *too low*. This will cause the electrode to stub.

3. **NA-5** - Set the DC-1000 mode switch to the process being used - CV(I) Innershield or CV(S) Sub Arc. Set the DC-1000 machine/remote switch in the remote position. Set the OCV control four volts higher than the welding voltage and the inch speed at 1/2 the welding wire feed speed for the initial test weld. Adjust the OCV and inch speed as required for optimum starting. Refer to the NA-5 instruction manual for data regarding the setup of controls and modes on the NA-5.
4. **LN-8** - Set the LN-8 mode switch (located on the CC board) to the CV position. Set the DC-1000 mode switch on CV(I) Innershield or CV(S) Sub Arc according to the process being used.
5. **LN-7, LN-9 and other constant wire feed units** - Set the DC-1000 mode switch on CV(I) Innershield or CV(S) Sub Arc according to the process being used. If using an LN-9, refer to the LN-9 instruction manual for further instructions on its use. If using an LN-7, it will be necessary to use either a K775 Remote Control or operate the DC-1000 with the machine/remote switch in the machine position.

NL Option Kit (Not Required with NA-3, NA-5, LT-7 or LT-56).

The K783 NL Option Kit (for field installation) is designed to permit use of the obsolete NA-2, LAF-3, LT-3 and LT-3 section of the LT-34 tractor. It provides the necessary DC control power for the operation of the equipment and the necessary circuitry for proper inching, cold starting and arc striking. *In using the NL Option Kit, a K775 remote field control is required and is included as part of the kit.* Installation instructions are included with the NL Option Kit.

SAFETY PRECAUTIONS

WARNING



ELECTRIC SHOCK can kill.

- **Only qualified personnel should perform this installation.**
 - **Turn the input power OFF at the disconnect switch or fuse box before working on this equipment.**
- **Do not touch electrically hot parts.**

The control board is designed with adequate protection so that no damage will occur if the remote control leads are shorted together or are grounded to the case. The machine will automatically shut down if such faults do occur.

An 8-amp fuse located on the machine control panel protects the 115 volt auxiliary AC circuit (#31 and #32) from overload. If replacing, use the same type and size fuse.

GENERAL MAINTENANCE

1. The fan motors have sealed bearings which require no service.
2. In extremely dusty locations, dirt may clog the air channels causing the welder to run hot. Blow out the welder with low pressure air at regular intervals as required to eliminate excessive dirt and dust buildup on internal parts.

OVERLOAD PROTECTION

The power source is thermostatically protected with two proximity thermostats against overload or insufficient cooling. One thermostat is located on the transformer secondary Negative Output Lead, and the other thermostat is located on the choke coil. The thermostats are connected in series in the machine control circuit so that if an excessive overload is applied to the machine, or the machine should receive insufficient cooling on either the main transformer, SCR bridge assembly or choke, the input contactor would open and remain open until the machine cools. It can then be manually restarted by operating the start push button.

The power source is also protected against heavy overloads on the SCR bridge assembly through an electronic protection circuit. This circuit senses an overload on the power source and opens the input contactor should the overload remain for a predetermined time. The predetermined time varies with the amount of overload; the greater the overload, the shorter the time. The input contactor will remain open until the power source is manually started with the start push button.

HOW TO USE TROUBLESHOOTING GUIDE

WARNING

Service and Repair should only be performed by Lincoln Electric Factory Trained Personnel. Unauthorized repairs performed on this equipment may result in danger to the technician and machine operator and will invalidate your factory warranty. For your safety and to avoid Electrical Shock, please observe all safety notes and precautions detailed throughout this manual.

This Troubleshooting Guide is provided to help you locate and repair possible machine malfunctions. Simply follow the three-step procedure listed below.

Step 1. LOCATE PROBLEM (SYMPTOM).

Look under the column labeled “PROBLEM (SYMPTOMS)”. This column describes possible symptoms that the machine may exhibit. Find the listing that best describes the symptom that the machine is exhibiting.

Step 2. POSSIBLE CAUSE.

The second column labeled “POSSIBLE CAUSE” lists the obvious external possibilities that may contribute to the machine symptom.

Step 3. RECOMMENDED COURSE OF ACTION

This column provides a course of action for the Possible Cause, generally it states to contact your local Lincoln Authorized Field Service Facility.

If you do not understand or are unable to perform the Recommended Course of Action safely, contact your local Lincoln Authorized Field Service Facility.

CAUTION

If for any reason you do not understand the test procedures or are unable to perform the tests/repairs safely, contact your **Local Lincoln Authorized Field Service Facility** for technical troubleshooting assistance before you proceed.

Observe all Safety Guidelines detailed throughout this manual

PROBLEMS (SYMPTOMS)	POSSIBLE CAUSE	RECOMMENDED COURSE OF ACTION
Input contactor (1CR) chatters.	<ol style="list-style-type: none"> 1. Faulty input contactor (1CR). 2. Low line voltage. 3. Faulty 2CR relay. 	<ol style="list-style-type: none"> 1. Repair or replace. 2. Check input power. 3. Repair relay.
Machine input contactor does not operate.	<ol style="list-style-type: none"> 1. Supply line fuse blown. 2. Contactor power circuit dead. 3. Broken power lead. 4. Wrong input voltage. 5. Secondary or choke thermostat open. 6. Open input contactor coil. 7. Faulty stop/start push button switch. 8. Faulty 2CR relay. 9. Defective control board. 	<ol style="list-style-type: none"> 1. Replace if blown - look for reason first. 2. Check pilot transformer T2 and associated leads. 3. Check input voltage at contactor. 4. Check voltage against instructions. 5. Check for overheating; make sure fan is operating and there is no obstruction to free air flow. Replace faulty thermostat. 6. Replace coil. 7. Replace switch. 8. Replace relay. 9. Replace control board. See P.C. board troubleshooting guide.
Input contactor pulls in when start button is pressed, but immediately drops out.	<ol style="list-style-type: none"> 1. Defective start/stop push button. 2. Defective 1CR interlock. 3. Ground fault between control terminals 73, 74, 75, 76 or 77 and negative output terminal. 4. Short on output terminals with 2-4 jumpered. 5. Defective control board. 	<ol style="list-style-type: none"> 1. Check and replace if necessary. 2. Repair or replace. 3. Check 73, 74, 75, 76 or 77 for ground to negative output circuit. 4. Remove short. 5. Replace control board. See P.C. board troubleshooting guide.
Machine input contactor operates but no output when trying to weld.	<ol style="list-style-type: none"> 1. Electrode or work lead loose or broken. 2. Open main transformer (T1) primary or secondary circuit. 3. Output pilot relay 4CR not operating or faulty. 4. Firing circuit P.C. board not connected or is faulty. 5. If using 500 amp stud, choke circuit may be open. 	<ol style="list-style-type: none"> 1. Repair connection. 2. Repair. 3. Check relay pull-in by connecting a jumper across terminals 2 and 4 on DC-1000 terminal strip. Replace if faulty. 4. All nine light emitting diodes (LED1 thru LED9) must be lit. See P.C. board troubleshooting guide. 5. Repair.

 **CAUTION**

If for any reason you do not understand the test procedures or are unable to perform the tests/repairs safely, contact your **Local Lincoln Authorized Field Service Facility** for technical troubleshooting assistance before you proceed.

IDEALARC® DC-1000



Observe all Safety Guidelines detailed throughout this manual

PROBLEMS (SYMPTOMS)	POSSIBLE CAUSE	RECOMMENDED COURSE OF ACTION
Machine has maximum output but not control.	<ol style="list-style-type: none"> 1. Output control switch (SW3) in wrong position. 2. Output control switch faulty. 3. Open in feedback circuitry. 4. Faulty control or firing circuit P.C. boards. 5. Output control potentiometer circuit open (Lead 75). 	<ol style="list-style-type: none"> 1. Check position of switch. 2. Check switch and replace if faulty. 3. Check wiring and control and firing circuit P.C. board wiring harness plugs. 4. All light emitting diodes must be lit, except LED4 on the control/fault board. See P.C. board troubleshooting guide. 5. Check and replace potentiometer if faulty. Check wiring of Lead #75.
Machine has minimum output and no control.	<ol style="list-style-type: none"> 1. Terminals 73, 74, 75, 76 or 77 grounded to <i>positive</i> output. 	<ol style="list-style-type: none"> 1. Check 73, 74, 75, 76 or 77 for ground to positive output circuit.
<p>Machine does not have maximum output.</p> <p>Machine has output but trips off immediately when wire feed unit start button is pressed.</p>	<ol style="list-style-type: none"> 1. One input fuse blown. 2. One phase of main transformer open. 3. Faulty control or firing circuit P.C. boards. 4. Output control potentiometer defective. 5. Output control potentiometer leads open - 76, 77, 226, 236, 237, 238. 	<ol style="list-style-type: none"> 1. Check and replace if blown after checking for reason for blown fuse. 2. Check for open and repair. 3. All light emitting diodes must be lit on both P.C. boards, except LED4 on control/fault board. See P.C. board troubleshooting guide. 4. Check and replace if faulty. 5. Repair.
Variable or sluggish welding arc.	<ol style="list-style-type: none"> 1. Machine has either an internal or external short circuit on the output. 2. Faulty control P.C. board. 3. Terminals 73, 74, 75, 76, 77 grounded to negative output terminal. 	<ol style="list-style-type: none"> 1. Check internally and externally for any shorts and remove or repair. 2. Replace control board. See P.C. board troubleshooting guide. 3. Check for grounded 73, 74, 75, 76, 77.
Machine will not shut off.	<ol style="list-style-type: none"> 1. Poor work or electrode connection. 2. Welding leads too small. 3. Welding current or voltage too low. 4. Defective main SCR bridge. 	<ol style="list-style-type: none"> 1. Check and clean all connections. 2. Check table in instruction manual. 3. Check procedures for recommended settings. 4. Check and replace if defective.
Output control not functioning on the machine ⁽¹⁾ .	<ol style="list-style-type: none"> 1. Input contactor contacts frozen. 2. Faulty 2CR relay. 	<ol style="list-style-type: none"> 1. Check and replace if necessary. 2. Check and replace if necessary.

⁽¹⁾ If connected to an LN-9 or NA-5, disconnect leads 73, 74, 75 before troubleshooting.

CAUTION

If for any reason you do not understand the test procedures or are unable to perform the tests/repairs safely, contact your **Local Lincoln Authorized Field Service Facility** for technical troubleshooting assistance before you proceed.

IDEALARC® DC-1000



Observe all Safety Guidelines detailed throughout this manual

PROBLEMS (SYMPTOMS)	POSSIBLE CAUSE	RECOMMENDED COURSE OF ACTION
Output control not functioning on remote control.	<ol style="list-style-type: none"> 1. Output control switch in wrong position. 2. Faulty output control switch. 3. Faulty remote control potentiometer. 4. Leads or connections open in control circuit. 5. Faulty firing or control circuit P.C. board. 	<ol style="list-style-type: none"> 1. Place switch in "Output Control Remote". 2. Check and replace if found faulty. 3. Check and replace if found faulty. (Voltage from 75 to 77 should be 3 to 5V). 4. Check all leads and connections, internal or remote, for continuity; repair if necessary. 5. All light emitting diodes must be lit on both P.C. boards, except LED4 on control/fault board. See P.C. board troubleshooting guide.
Poor starting on CV(S) Sub-Arc.	<ol style="list-style-type: none"> 1. Improper procedures or setting of controls. 2. Poor electrode or work connection. 3. 3CR reed switch inoperative. 4. Faulty control board. 	<ol style="list-style-type: none"> 1. See instruction manual and procedures. 2. Repair connections. 3. Check reed switch voltage leads 216 to 220. Idle voltage is about 8V; when welding, voltage must go to zero. 4. Replace. See P.C. board troubleshooting guide.
Poor bead shape or erratic arc on CV(S) Sub-Arc.	<ol style="list-style-type: none"> 1. Improper procedures. 2. Defective 3CR reed switch. 3. Faulty control board. 4. Defective main SCR bridge. 	<ol style="list-style-type: none"> 1. See instruction manual and procedures. 2. Check reed switch per item c. of previous Table above. 3. Replace. See P.C. board troubleshooting guide. 4. Check and replace if defective.
Poor starting on CV(I) Innershield and CV(S) Sub-Arc.	<ol style="list-style-type: none"> 1. Defective 3CR reed switch. 2. Faulty control board. 	<ol style="list-style-type: none"> 1. Replace. 2. Replace.
Poor arc characteristics on CV(I) Innershield or other open arc processes.	<ol style="list-style-type: none"> 1. Mode switch in CV(S) Sub-Arc mode. 2. Defective main SCR bridge. 	<ol style="list-style-type: none"> 1. Place mode switch in CV(I) Innershield mode. 2. Check and replace if defective.
Poor arc characteristics on all processes.	<ol style="list-style-type: none"> 1. Defective control board. 2. Defective firing board. 3. Defective main SCR bridge. 	<ol style="list-style-type: none"> 1. Check and replace if defective. See P.C. board troubleshooting guide. 2. Check and replace if defective. See P.C. board troubleshooting guide. 3. Check and replace if defective.
Poor performance (including arc outages) while welding at low current (less than 450 amps) when connected to 1000 amp "+" output studs.	<ol style="list-style-type: none"> 1. Insufficient output inductance. 	<ol style="list-style-type: none"> 1. Use the 500 amp "+" output stud.
Machine frequently shuts off while using the 500 amp "+" output stud.	<ol style="list-style-type: none"> 1. Effective current demand well over 500 amperes. 	<ol style="list-style-type: none"> 1. Use the 1000 amp "+" output studs.

 **CAUTION**

If for any reason you do not understand the test procedures or are unable to perform the tests/repairs safely, contact your **Local Lincoln Authorized Field Service Facility** for technical troubleshooting assistance before you proceed.

IDEALARC® DC-1000



Observe all Safety Guidelines detailed throughout this manual

P.C. BOARD TROUBLESHOOTING GUIDE

⚠ WARNING



ELECTRIC SHOCK can kill.

- Have an electrician install and service this equipment.
- Turn the input power off at the fuse box before working on equipment.
- Do not touch electrically hot parts.

Machine settings for P.C. board troubleshooting. Disconnect all leads to the wire feeder and jumper terminals #2 and #4 on DC-1000. Output Control at DC-1000. Mode switch in the CV(I) position.

CONTROL/FAULT PROTECTION P.C. BOARD

1. LED1 indicates AC input voltage is present at pins 255-256. If not lit, check the voltage across the secondary winding of the control transformer, T2. The voltage should be approximately 115 volts. If not, the problem is in the power supply and not the P.C. board.
2. LED2 indicates welder output voltage is being supplied to the control circuit. If not lit, check to make certain lead 222 from pin 2 of the 15-pin control circuit P.C. board connector is connected to the power source negative output lead and is not broken.
3. LED3 indicates power is being applied to fault protection pilot relay 2CR to turn on the input contactor.
4. LED4 indicates when overcurrent protection circuit is being activated.
5. LED5 indicates a control signal is being supplied to the firing circuit. As the output control is varied, LED5 should change brilliancy from bright at low output to dim at high output.

FIRING CIRCUIT P.C. BOARD

All nine light emitting diodes must be lit when the power source is turned on and the wire feed arc start button is pressed or a jumper is connected between 2 and 4.

1. Lights 7, 8, and 9 indicate AC power being supplied to the P.C. boards from T1 auxiliary winding. If a light is not lit, turn the machine off and unplug P5 from J5 on the firing P.C. board. Turn the machine on and check the following voltages:

Light That Was Off	Check AC Voltage Between Pins of Plug P5	Voltage Should Be Approx.
7	P5 Pins 2 & 4 (Wires 203, 204)	75 VAC
8	P5 Pins 7 & 3 (Wires 205, 206)	75 VAC
9	P5 Pins 9 & 8 (Wires 207, 208)	75 VAC

- If approximately 75 VAC is present, turn the machine off, plug P5 back into firing board. Turn the machine back on and check to see if the light or lights are on. If the light or lights are not on replace the firing P.C. board.
 - If the 75 VAC was not present, then check the wiring.
2. Lights 1 through 6 indicate gate signals are being supplied to the main power SCR's 1 through 6 respectively. If light 5 on the control circuit and lights 7 through 9 on the firing circuit are lit and lights 1 through 6 are not lit, check lead 231 between the firing circuit and the control circuit that it is not broken and is connected to each Molex connector. If the lead shows continuity and lights 1 through 6 are not lit, replace the firing circuit P.C. board. If any one of the lights 1 through 6 is not lit and lights 7 through 9 are lit, replace the firing circuit P.C. board.

⚠ CAUTION

If for any reason you do not understand the test procedures or are unable to perform the tests/repairs safely, contact your **Local Lincoln Authorized Field Service Facility** for technical troubleshooting assistance before you proceed.

IDEALARC® DC-1000



Observe all Safety Guidelines detailed throughout this manual

PROCEDURE FOR REPLACING P.C. BOARDS

When P.C. board is to be replaced, the following procedure must be followed:

1. Visually inspect P.C. board in question. Are any of the components damaged? Is a conductor on the back side of the board damaged? All P.C. boards are protected by a moisture resistant coating. When the welder is operated, this coating will “bake off” of certain power resistors that normally operate at high temperatures emitting some smoke and odor for a short time. These resistors and the P.C. board beneath them may become blackened. This is a normal occurrence and does not damage the component or affect the machine performance.
 - a. If there is no damage to the P.C. board, insert a new one and see if this remedies the problem. If the problem is remedied, replace the old P.C. board and see if the problem still exists with the old P.C. board.
 - 1) If the problem is no longer present with the old board, check the P.C. board harness plug and P.C. board plug for corrosion, contamination, or oversize.
 - 2) Check leads in the harness for loose connections.
 - b. If there is damage to the P.C. board, refer to the Troubleshooting Guide

CAUTION

If for any reason you do not understand the test procedures or are unable to perform the tests/repairs safely, contact your **Local Lincoln Authorized Field Service Facility** for technical troubleshooting assistance before you proceed.

IDEALARC® DC-1000



OUTLINE FOR DC-1000 TROUBLESHOOTING GUIDE

If troubleshooting guide indicates a possible P.C. board problem, the following guide can be used to locate the problem.

NO WELDER OUTPUT (INPUT CONTACTOR "ON". 2 AND 4 CLOSED)

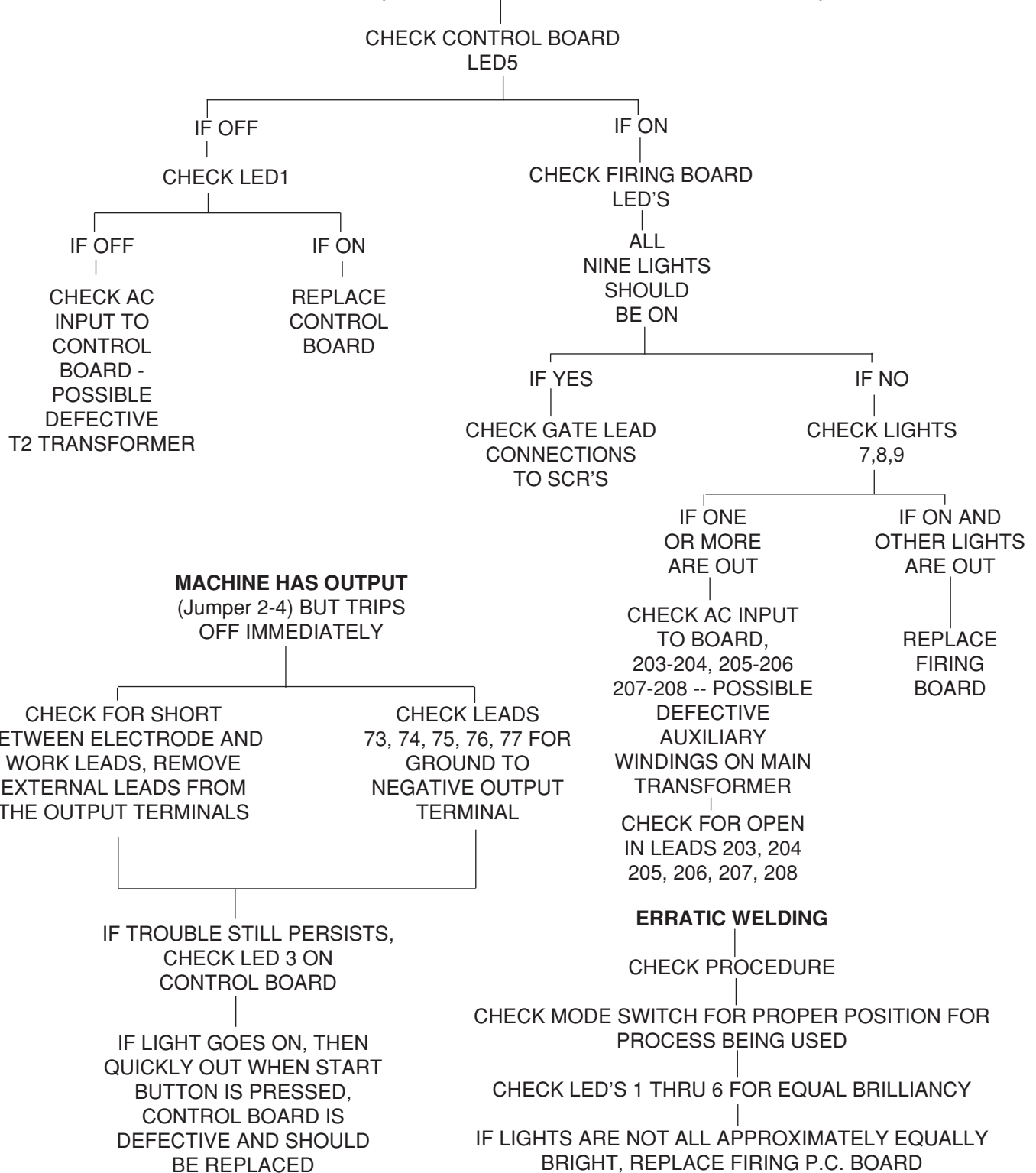

CAUTION

If for any reason you do not understand the test procedures or are unable to perform the tests/repairs safely, contact your **Local Lincoln Authorized Field Service Facility** for technical troubleshooting assistance before you proceed.

IDEALARC® DC-1000



CONNECTION OF DC-1000 WITH NL OPTION KIT TO LAF-3 (Obsolete)

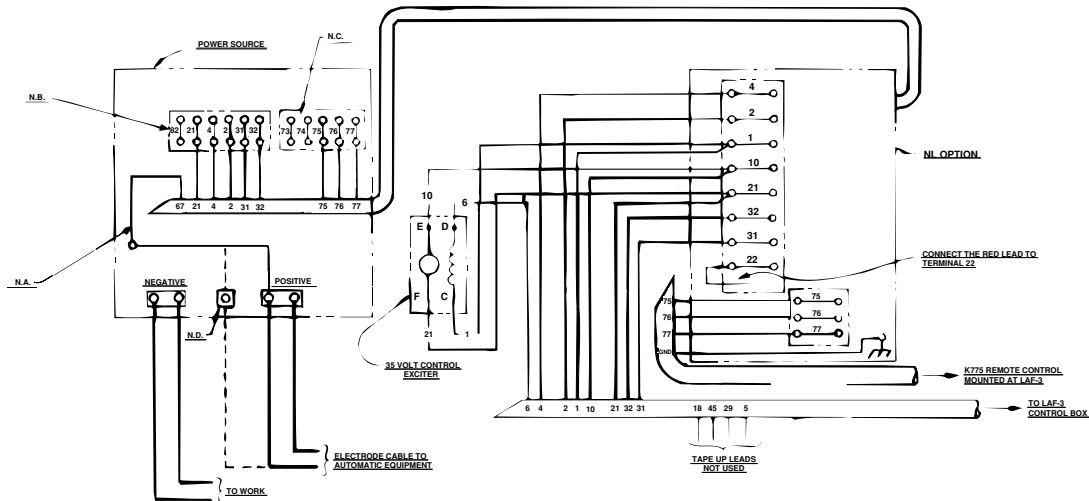

M13321
8-2-90F

- N.A. On all DC-1000 and DC-1500 units with codes above 8234 extend lead 67 and connect it to the electrode cable going to the automatic equipment.
- N.B. On DC-1500 units below code 8234 this is 67 and the LAF-3 #67 lead can be connected either to the #67 terminal or the electrode cable terminal as shown. Terminal 82 not present on later D.C. 1500's and all DC-1000's.
- N.C. Terminals 73 and 74 not present on earlier DC-1500's.

- N.D. Alternative 500 amp positive terminal connection provided on DC-1000 models above code 9500 only.
- This diagram shows the electrode connected positive. To change polarity, turn power source off, reverse the electrode and work leads at the power source and position the switch on the power source and NL Option Kit to the proper polarity. Also reverse the leads on the back of the ammeter and voltmeter in the LAF-3 control box.
- Contactor drop out delay switch on the NL Option Kit must be in the "On" position.

The 4/0 cables shown will handle up to 1000 amps at 80% duty cycle. For higher currents or duty cycle add additional cables to the power source output studs.

For best arc striking when connected to an LAF-3 make the following change inside the LAF-3 control unit. Remove the blue jumper lead connected between #1 on the coil of the main relay and #7 on the coil of the transfer relay. (The main relay is the upper right relay when facing the left end of the control box. The transfer relay is just to the left of the main relay.)

CONNECTION OF DC-1000 TO LN-8

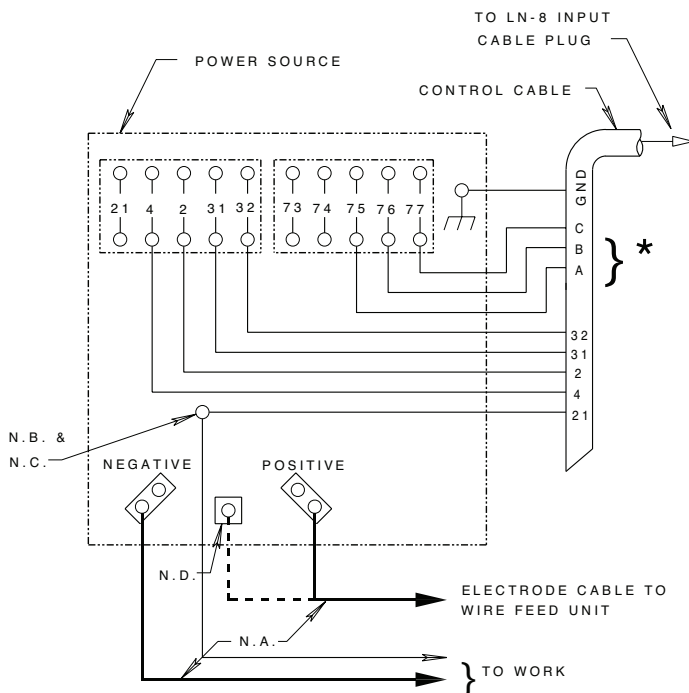

S17176
8-2-90F

Connect the control cable ground lead to the frame terminal marked **77** near the power source terminal strip. The power source must be properly grounded.

*If using an older control cable: Connect lead #75 to #75 on terminal strip, connect lead #76 to #76 on terminal strip, connect lead #77 to #77 on terminal strip.

- N.A. Welding cables must be of proper capacity for the current and duty cycle of immediate and future applications.
- N.B. Extend lead 21 using #14 or larger insulated wire physically suitable for the installation. An S16586-[] remote voltage sensing work lead is available for this purpose. Connect it directly to the work piece keeping it electrically separate from the welding work lead circuit and connection. For convenience, this extended #21 lead should be taped to the welding work lead.
- N.C. Tape up bolted connection.
- N.D. Alternative 500 amp positive terminal connection provided on DC-1000 models above code 9500 only.

Above diagram shows electrode connected positive. To change polarity, turn power source off, reverse the electrode and work leads at the power source and position the switch on power source to proper polarity.

CONNECTION OF DC-1000 WITH NL OPTION KIT TO LT-3 or LT-34 (Obsolete)

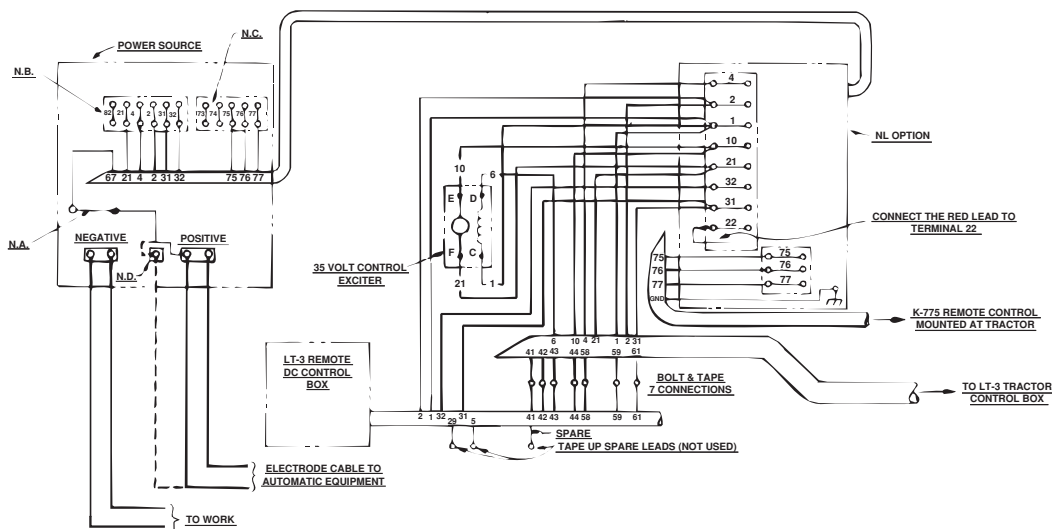

M13322
8-2-90F

- N.A. On all DC-1000 and DC-1500's above Code 8234 extend lead 67 and connect it to the electrode cable going to the automatic equipment.
- N.B. On DC-1500 units below code 8234 this is #67 and the LT-3 or LT-34 #67 lead can be connected either to the #67 or the electrode cable terminal as shown. Terminal 82 not present on later D.C. 1500's and all DC-1000's.

- N.C. Terminals 73 & 74 not present on earlier DC-1500's.
- N.D. Alternative 500 amp positive terminal connection provided on DC-1000 models above code 9500 only.

Contactor drop out delay switch on the NL Option Kit must be in the "On" position.

The 4/0 cables shown will handle up to 1000 amps at 80% duty cycle. For higher currents or duty cycle add additional cables to the power source output studs.

This diagram shows the electrode connected positive. To change polarity, turn power source off, reverse the electrode and work leads at the power source and position the switch on the power source and NL Option Kit to the proper polarity. Also reverse the leads on the back of the ammeter and voltmeter in the LT-3 control box.

CONNECTION OF DC-1000 OR DC-1500 to NA-3, LT-5 or LT-7

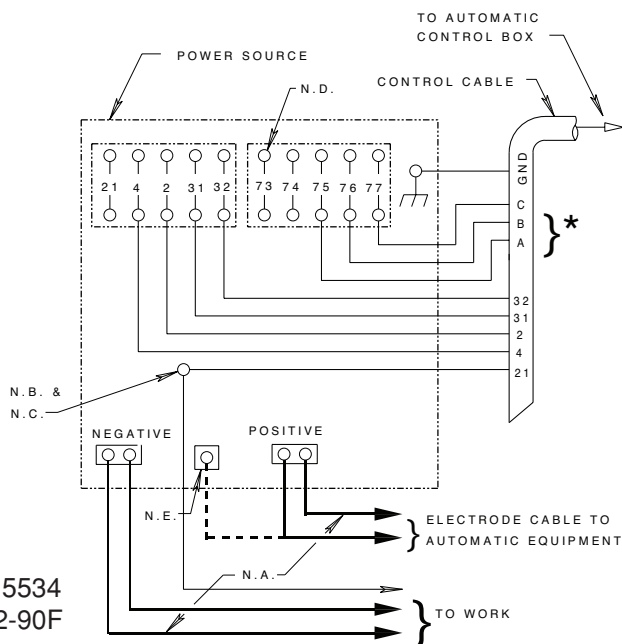

S15534
8-2-90F

Connect the control cable ground lead to the frame terminal marked  near the power source terminal strip. The power source must be properly grounded.

*If using an older control cable: Connect lead #75 to #75 on terminal strip, connect lead #76 to #76 on terminal strip, connect lead #77 to #77 on terminal strip.

- N.A. Welding cables must be of proper capacity for the current and duty cycle of immediate and future applications.
- N.B. Extend lead 21 using #14 or larger insulated wire physically suitable for the installation. An S16586-[] remote voltage sensing work lead is available for this purpose. Connect it directly to the work piece keeping it electrically separate from the welding work lead circuit and connection. For convenience, this extended #21 lead should be taped to the welding work lead.
- N.C. Tape up bolted connection.
- N.D. Terminals 73 & 74 not present on earlier DC-1500.
- N.E. Alternative 500 amp positive terminal connection provided on DC-1000 models above code 9500 only.

Above diagram shows electrode connected positive. To change polarity, turn power source off, reverse the electrode and work leads at the power source and position the switch on power source to proper polarity. Also reverse the leads on the back of the ammeter and voltmeter in the automatic control box.

IDEALARC® DC-1000



CONNECTION OF DC-1000 to NA-5

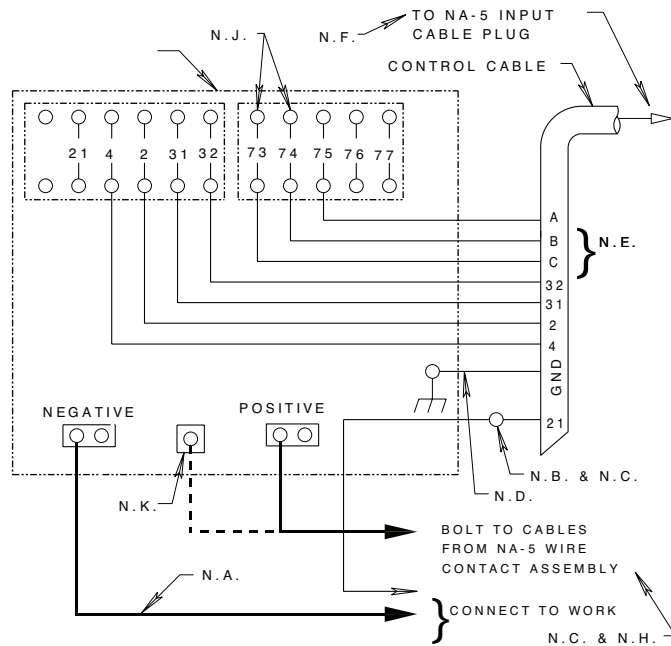

S16889
8-2-90F

Above diagram shows electrode connected positive. To change polarity turn power off, reverse the electrode and work leads at the power source, position the positive - negative switch on the power source to correspond to the polarity of the electrode cable connection. Refer to NA-5 operating manual for required NA-5 control box polarity connections.

N.A. Welding cables must be of proper capacity for the current and duty cycle of immediate and future applications.

N.B. Extend lead 21 using #14 or larger insulated wire physically suitable for the installation. An S16586-[] remote voltage sensing work lead is available for this purpose. Connect it directly to the work piece keeping it separate from the welding work cable connection to work piece. For convenience, this extended #21 lead should be taped along the welding work cable.

N.C. Tape up bolted connection.

N.D. Connect the NA-5 control cable ground lead to the frame terminal marked $\overline{\text{N}}$ near the power source terminal strip. The power source must be properly grounded.

N.E. If using an older automatic control cable with leads 75, 76, 77: Connect lead 75 to #75 on terminal strip, connect lead #76 to #74 on terminal strip, connect lead #77 to #73 on terminal strip.

N.F. Connect the jumpers on the NA-5 voltage board as follows: Connect RED jumper to pin "S", Connect WHITE jumper to pin "B".

N.G. Set the DC-1000 or DC-1500 controls as follows: Set the control switch to "Output Control Remote". For Submerged Arc Processes set the switch to "C.V. Submerged Arc". For Open Arc Processes, set the mode switch to "C.V. Innershield".

N.H. For proper operation, the electrode cable *must* be snugged under the clamp bar on the left side of the NA-5 control box.

N.J. Terminals #73 and #74 were not present on DC-1500 machines below code 8294. These earlier code machines are not suitable for use with the NA-5.

N.K. Alternative 500 amp positive terminal connection provided on DC-1000 models above code 9500 only.

N.L. Alternate submerged arc mode available for improved arc stability in high current, large puddle, slow travel procedures by making special connections on both DC-1500 and NA-5.

On DC-1500 Control Board (G1530-2 and superseding) remove red and blue jumpers from "FR" pins and reconnect to corresponding "SR" pins.

On NA-5 Voltage Board (G1556-1 and superseding) white jumper must be connected to pin "D".

NA-5 pin "D" connection may also be used for some procedures on DC-1500 without control board jumpers, DC-1500 with control board jumpers on "FR" pins or DC-1000.

CONNECTION OF DC-1000 TO LN-7

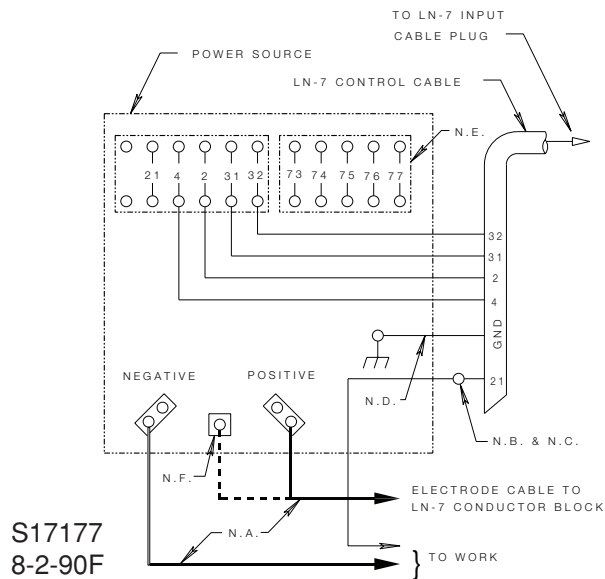

Above diagram shows electrode connected positive. To change polarity, turn power off, reverse the electrode and work leads at the power source and position the switch on power source to proper polarity.

- N.A. Welding cables must be of proper capacity for the current and duty cycle of immediate and future applications.
- N.B. Extend lead 21 using #14 or larger insulated wire physically suitable for the installation. An S16586-[] remote voltage sensing work lead is available for this purpose. Connect it directly to the work piece keeping it electrically separate from the welding work lead circuit and connection. For convenience, this extended #21 lead should be taped to the welding work lead. (This extended #21 lead connection replaces the need to employ the remote work lead accessory on LN-7 meter kits which have a direct work lead jack. An LN-7 not equipped with a meter kit does not require lead 21 to be extended.)
- N.C. Tape up bolted connection.
- N.D. Connect the control cable ground lead to the frame terminal marked  near the power source terminal strip. The power source must be properly grounded.
- N.E. Terminal strip for remote voltage control pot. when used.
- N.F. Alternative 500 amp positive terminal connection provided on DC-1000 models above code 9500 only.

CONNECTION OF DC-1000 TO LN-9

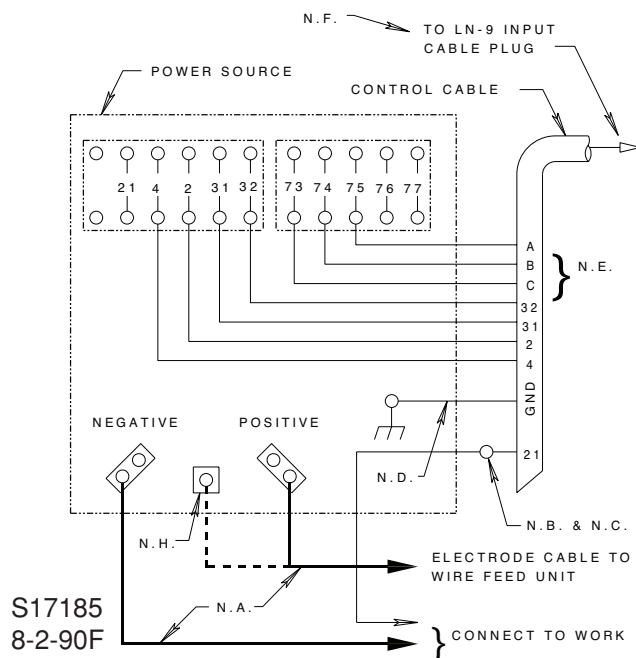

Above diagram shows electrode connected positive. To change polarity, turn power off, reverse the electrode and work leads at the power source, position the positive-negative switch on the power source to correspond to the polarity of the electrode cable connection. Refer to LN-9 operating manual for required polarity connections.

- N.A. Welding cables must be of proper capacity for the current and duty cycle of immediate and future applications.
- N.B. Extend lead 21 using #14 or larger insulated wire physically suitable for the installation. An S16586-[] remote voltage sensing work lead is available for this purpose. Connect it directly to the work piece keeping it separate from the welding work cable connection to work piece. For convenience, this extended #21 lead should be taped along the welding work cable. (This extended #21 lead connection replaces the need to employ the remote work lead accessory on LN-9's which have a direct work lead jack.)
- N.C. Tape up bolted connection.
- N.D. Connect the LN-9 control cable ground lead to the frame terminal marked  near the power source terminal strip. The power source must be properly grounded.
- N.E. If using an older automatic control cable with leads 75, 76, 77; Connect lead 75 to #75 on terminal strip, connect lead #76 to #74 on terminal strip, connect lead #77 to #73 on terminal strip.
- N.F. The LN-9 voltage control jumpers must be connected as follows (Refer to LN-9 operating manual): White jumper on voltage board to pin "S". Blue jumper on voltage board (later units only) or on start board (earlier units). To pin "B".
- N.G. Set the DC-1000 controls as follows: Set the control switch to "Output Control Remote". For Submerged Arc Processes, set the mode switch to "C.V. Innershield".
- N.H. Alternative 500 amp positive terminal connection provided on DC-1000 models above code 9500 only.

DC-1000 WIRING DIAGRAM FOR CODES 9919 - 9925, 11305, 11330, 11331, 11332, 11333, 11334

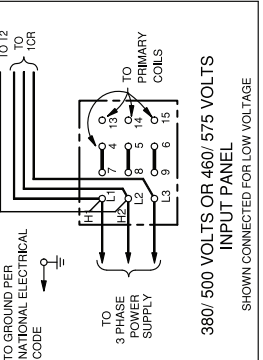
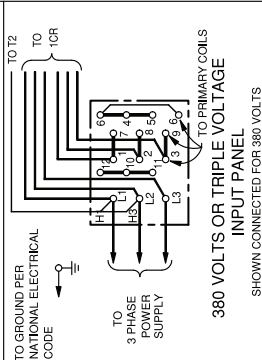
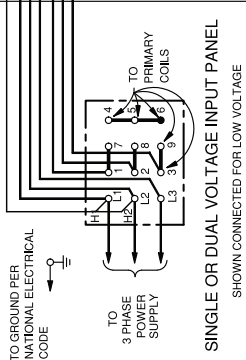
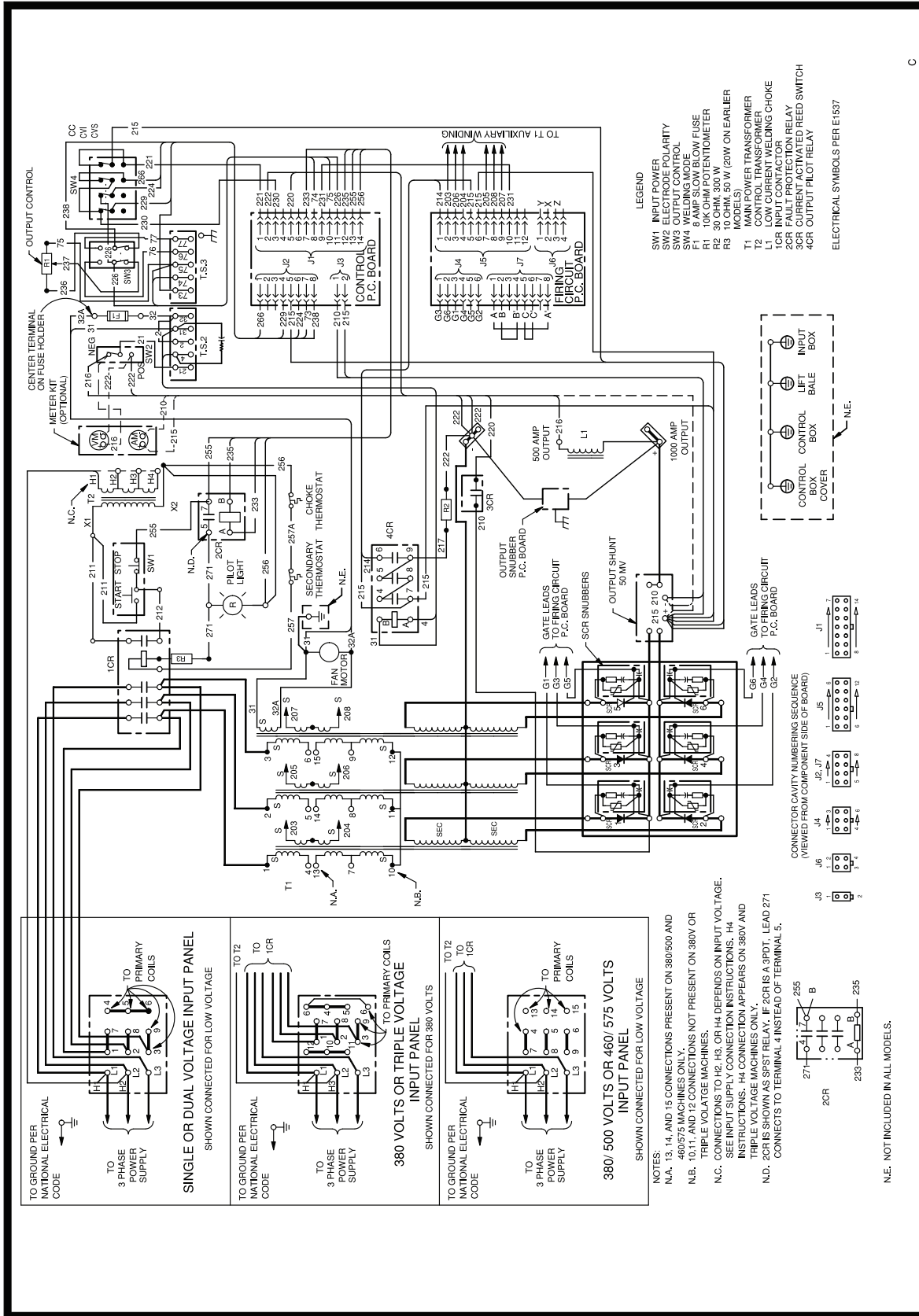

NOTES:
 N.A. 13, 14, AND 15 CONNECTIONS PRESENT ON 380/500 AND 460/575 MACHINES. CONNECTIONS NOT PRESENT ON 380V OR TRIPLE VOLTAGE MACHINES.
 N.B. CONNECTIONS TO L2, L3, OR L4 DEPENDS ON INPUT VOLTAGE. SEE INPUT SUPPLY CONNECTION INSTRUCTIONS, I-4.
 INSTRUCTIONS, I-4 CONNECTION APPEARS ON 380V AND TRIPLE VOLTAGE MACHINES ONLY.
 N.D. 2CR IS SHOWN AS SPST RELAY. IF 2CR IS A 3PDT, LEAD 271 CONNECTS TO TERMINAL 4 INSTEAD OF TERMINAL 5.

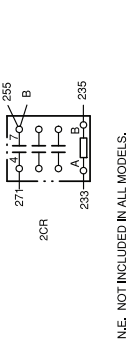

- LEGEND
- SW1 INPUT POWER
 - SW2 ELECTRODE POLARITY
 - SW3 OUTPUT CONTROL
 - SW4 WELDING MODE
 - F1 8 AMP SLOW BLOW FUSE
 - R2 30 OHM PERCENTOMETER
 - R3 10 OHM 50 W (20W ON EARLIER MODELS)
 - T1 MAIN POWER TRANSFORMER
 - T2 CONTROL TRANSFORMER
 - 1CR INPUT CONTACTOR
 - 2CR FAULT PROTECTION RELAY
 - 3CR CURRENT ACTIVATED REED SWITCH
 - 4CR OUTPUT PILOT RELAY
- ELECTRICAL SYMBOLS PER E1537

L9008

NOTE: This diagram is for reference only. It may not be accurate for all machines covered by this manual. The specific diagram for a particular code is pasted inside the machine on one of the enclosure panels. If the diagram is illegible, write to the Service Department for a replacement. Give the equipment code number.



WIRING DIAGRAM IDEALARC DC-1000 FOR CODES 11681 THRU 11684

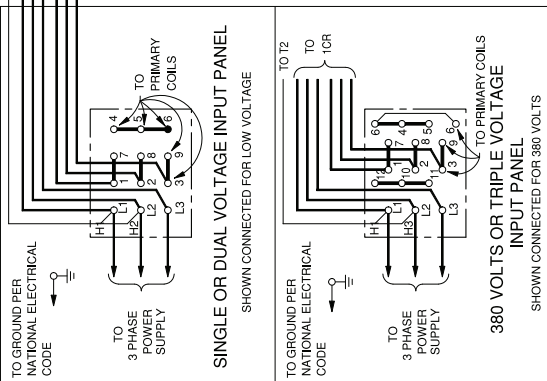
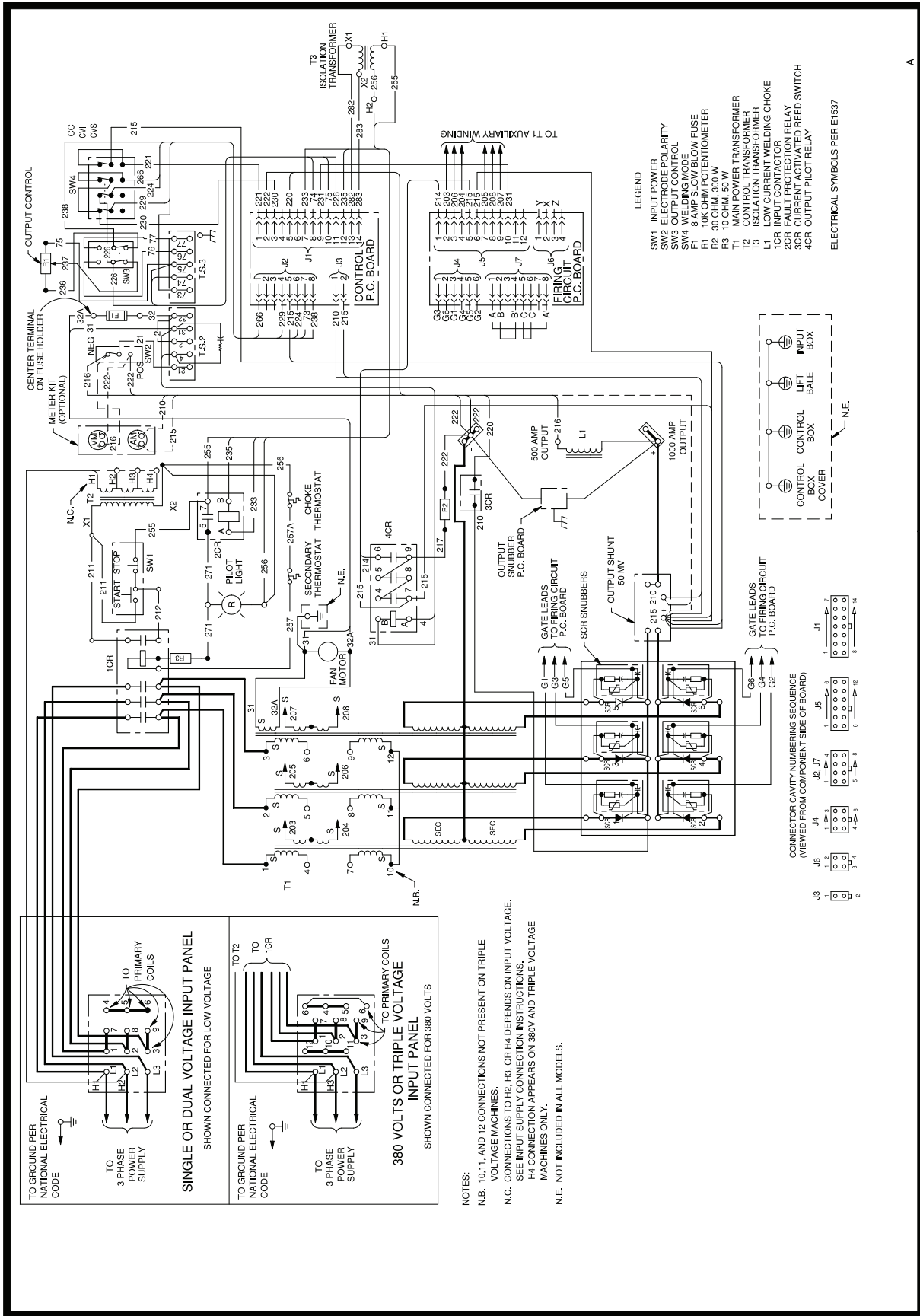

NOTES:
 N.B. 10,11, AND 12 CONNECTIONS NOT PRESENT ON TRIPLE VOLTAGE MACHINES.
 N.C. CONNECTIONS TO H2, H3, OR H4 DEPENDS ON INPUT VOLTAGE. SEE INPUT SUPPLY CONNECTION INSTRUCTIONS.
 H4 CONNECTION APPEARS ON 380V AND TRIPLE VOLTAGE MACHINES ONLY.
 N.E. NOT INCLUDED IN ALL MODELS.

LEGEND
 SW1 INPUT POWER
 SW2 ELECTRODE POLARITY
 SW3 OUTPUT CONTROL
 SW4 WELDING MODE
 F1 8 AMP SLOW BLOW FUSE
 F2 30 OHM 300 W
 F3 10 OHM 50 W
 T1 MAIN POWER TRANSFORMER
 T2 CONTROL TRANSFORMER
 T3 ISOLATION TRANSFORMER
 L1 LOW CURRENT WELDING CHOKE
 ICR INPUT CURRENT RELAY
 2CR FAULT PROTECTION RELAY
 3CR CURRENT ACTIVATED REED SWITCH
 4CR OUTPUT PILOT RELAY

CONNECTOR CAVITY NUMBERING SEQUENCE (VIEWED FROM COMPONENT SIDE OF BOARD)

J1	1	2	3	4	5	6	7	8	9	10	11	12
J2, J7	1	2	3	4	5	6	7	8	9	10	11	12
J3	1	2	3	4	5	6	7	8	9	10	11	12
J4	1	2	3	4	5	6	7	8	9	10	11	12
J5	1	2	3	4	5	6	7	8	9	10	11	12
J6	1	2	3	4	5	6	7	8	9	10	11	12

NOTE: This diagram is for reference only. It may not be accurate for all machines covered by this manual. The specific diagram for a particular code is pasted inside the machine on one of the enclosure panels. If the diagram is illegible, write to the Service Department for a replacement. Give the equipment code number.

NOTES

IDEALARC® DC-1000



NOTES

IDEALARC® DC-1000



NOTES

IDEALARC® DC-1000



WARNING	<ul style="list-style-type: none"> Do not touch electrically live parts or electrode with skin or wet clothing. Insulate yourself from work and ground. 	<ul style="list-style-type: none"> Keep flammable materials away. 	<ul style="list-style-type: none"> Wear eye, ear and body protection.
Spanish AVISO DE PRECAUCION	<ul style="list-style-type: none"> No toque las partes o los electrodos bajo carga con la piel o ropa mojada. Aislese del trabajo y de la tierra. 	<ul style="list-style-type: none"> Mantenga el material combustible fuera del área de trabajo. 	<ul style="list-style-type: none"> Protéjase los ojos, los oídos y el cuerpo.
French ATTENTION	<ul style="list-style-type: none"> Ne laissez ni la peau ni des vêtements mouillés entrer en contact avec des pièces sous tension. Isolez-vous du travail et de la terre. 	<ul style="list-style-type: none"> Gardez à l'écart de tout matériel inflammable. 	<ul style="list-style-type: none"> Protégez vos yeux, vos oreilles et votre corps.
German WARNUNG	<ul style="list-style-type: none"> Berühren Sie keine stromführenden Teile oder Elektroden mit Ihrem Körper oder feuchter Kleidung! Isolieren Sie sich von den Elektroden und dem Erdboden! 	<ul style="list-style-type: none"> Entfernen Sie brennbares Material! 	<ul style="list-style-type: none"> Tragen Sie Augen-, Ohren- und Körperschutz!
Portuguese ATENÇÃO	<ul style="list-style-type: none"> Não toque partes elétricas e electrodos com a pele ou roupa molhada. Isole-se da peça e terra. 	<ul style="list-style-type: none"> Mantenha inflamáveis bem guardados. 	<ul style="list-style-type: none"> Use proteção para a vista, ouvido e corpo.
Japanese 注意事項	<ul style="list-style-type: none"> ● 通電中の電気部品、又は溶材にヒブやぬれた布で触れないこと。 ● 施工物やアースから身体が絶縁されている様にして下さい。 	<ul style="list-style-type: none"> ● 燃えやすいものの側での溶接作業は絶対にしてはなりません。 	<ul style="list-style-type: none"> ● 目、耳及び身体に保護具をして下さい。
Chinese 警告	<ul style="list-style-type: none"> ● 皮肤或湿衣物切勿接触带电部件及焊条。 ● 使你自已与地面和工作件绝缘。 	<ul style="list-style-type: none"> ● 把一切易燃物品移离工作场所。 	<ul style="list-style-type: none"> ● 佩戴眼、耳及身体劳动保护用具。
Korean 위험	<ul style="list-style-type: none"> ● 전도체나 용접봉을 젖은 헝겍 또는 피부로 절대 접촉치 마십시오. ● 모재와 접지를 접촉치 마십시오. 	<ul style="list-style-type: none"> ● 인화성 물질을 접근시키지 마십시오. 	<ul style="list-style-type: none"> ● 눈, 귀와 몸에 보호장구를 착용하십시오.
Arabic تحذير	<ul style="list-style-type: none"> ● لا تلمس الاجزاء التي يسري فيها التيار الكهربائي أو الألكترود بجلد الجسم أو بالملايس المبللة بالماء. ● وضع عازلا على جسمك خلال العمل. 	<ul style="list-style-type: none"> ● ضع المواد القابلة للاشتعال في مكان بعيد. 	<ul style="list-style-type: none"> ● ضع أدوات وملابس واقية على عينيك وأذنيك وجسمك.

READ AND UNDERSTAND THE MANUFACTURER'S INSTRUCTION FOR THIS EQUIPMENT AND THE CONSUMABLES TO BE USED AND FOLLOW YOUR EMPLOYER'S SAFETY PRACTICES.

SE RECOMIENDA LEER Y ENTENDER LAS INSTRUCCIONES DEL FABRICANTE PARA EL USO DE ESTE EQUIPO Y LOS CONSUMIBLES QUE VA A UTILIZAR, SIGA LAS MEDIDAS DE SEGURIDAD DE SU SUPERVISOR.

LISEZ ET COMPRENEZ LES INSTRUCTIONS DU FABRICANT EN CE QUI REGARDE CET EQUIPMENT ET LES PRODUITS A ETRE EMPLOYES ET SUIVEZ LES PROCEDURES DE SECURITE DE VOTRE EMPLOYEUR.

LESEN SIE UND BEFOLGEN SIE DIE BETRIEBSANLEITUNG DER ANLAGE UND DEN ELEKTRODENEINSATZ DES HERSTELLERS. DIE UNFALLVERHÜTUNGSVORSCHRIFTEN DES ARBEITGEBERS SIND EBENFALLS ZU BEACHTEN.

			
<ul style="list-style-type: none"> • Keep your head out of fumes. • Use ventilation or exhaust to remove fumes from breathing zone. 	<ul style="list-style-type: none"> • Turn power off before servicing. 	<ul style="list-style-type: none"> • Do not operate with panel open or guards off. 	WARNING
<ul style="list-style-type: none"> • Los humos fuera de la zona de respiración. • Mantenga la cabeza fuera de los humos. Utilice ventilación o aspiración para gases. 	<ul style="list-style-type: none"> • Desconectar el cable de alimentación de poder de la máquina antes de iniciar cualquier servicio. 	<ul style="list-style-type: none"> • No operar con panel abierto o guardas quitadas. 	Spanish AVISO DE PRECAUCION
<ul style="list-style-type: none"> • Gardez la tête à l'écart des fumées. • Utilisez un ventilateur ou un aspirateur pour ôter les fumées des zones de travail. 	<ul style="list-style-type: none"> • Débranchez le courant avant l'entretien. 	<ul style="list-style-type: none"> • N'opérez pas avec les panneaux ouverts ou avec les dispositifs de protection enlevés. 	French ATTENTION
<ul style="list-style-type: none"> • Vermeiden Sie das Einatmen von Schweißrauch! • Sorgen Sie für gute Be- und Entlüftung des Arbeitsplatzes! 	<ul style="list-style-type: none"> • Strom vor Wartungsarbeiten abschalten! (Netzstrom völlig öffnen; Maschine anhalten!) 	<ul style="list-style-type: none"> • Anlage nie ohne Schutzgehäuse oder Innenschutzverkleidung in Betrieb setzen! 	German WARNUNG
<ul style="list-style-type: none"> • Mantenha seu rosto da fumaça. • Use ventilação e exaustão para remover fumo da zona respiratória. 	<ul style="list-style-type: none"> • Não opere com as tampas removidas. • Desligue a corrente antes de fazer serviço. • Não toque as partes elétricas nuas. 	<ul style="list-style-type: none"> • Mantenha-se afastado das partes moventes. • Não opere com os painéis abertos ou guardas removidas. 	Portuguese ATENÇÃO
<ul style="list-style-type: none"> ● ヒュームから頭を離すようにして下さい。 ● 換気や排煙に十分留意して下さい。 	<ul style="list-style-type: none"> ● メンテナンス・サービスに取りかかる際には、まず電源スイッチを必ず切して下さい。 	<ul style="list-style-type: none"> ● パネルやカバーを取り外したまま機械操作をしないで下さい。 	Japanese 注意事項
<ul style="list-style-type: none"> ● 頭部遠離煙霧。 ● 在呼吸區使用通風或排風器除煙。 	<ul style="list-style-type: none"> ● 維修前切斷電源。 	<ul style="list-style-type: none"> ● 儀表板打開或沒有安全罩時不準作業。 	Chinese 警告
<ul style="list-style-type: none"> ● 얼굴로부터 용접가스를 멀리하십시오. ● 호흡지역으로부터 용접가스를 제거하기 위해 가스제거기나 통풍기를 사용하십시오. 	<ul style="list-style-type: none"> ● 보수전에 전원을 차단하십시오. 	<ul style="list-style-type: none"> ● 판넬이 열린 상태로 작동치 마십시오. 	Korean 위험
<ul style="list-style-type: none"> ● ابعدها رأسك بعيداً عن الدخان. ● استعمل التهوية أو جهاز ضغط الدخان للخارج لكي تبعد الدخان عن المنطقة التي تتنفس فيها. 	<ul style="list-style-type: none"> ● اقطع التيار الكهربائي قبل القيام بأية صيانة. 	<ul style="list-style-type: none"> ● لا تشغيل هذا الجهاز اذا كانت الاغطية الحديدية الواقية ليست عليه. 	Arabic تحذير

LEIA E COMPREENDA AS INSTRUÇÕES DO FABRICANTE PARA ESTE EQUIPAMENTO E AS PARTES DE USO, E SIGA AS PRÁTICAS DE SEGURANÇA DO EMPREGADOR.

使う機械や溶材のメーカーの指示書をよく読み、まず理解して下さい。そして貴社の安全規定に従って下さい。

請詳細閱讀並理解製造廠提供的說明以及應該使用的銀焊材料，並請遵守貴方的有閣勞動保護規定。

이 제품에 동봉된 작업지침서를 숙지하시고 귀사의 작업자 안전수칙을 준수하시기 바랍니다.

اقرأ بتمعن وافهم تعليمات المصنع المنتج لهذه المعدات والمواد قبل استعمالها واتبع تعليمات الوقاية لصاحب العمل.



• World's Leader in Welding and Cutting Products •

• Sales and Service through Subsidiaries and Distributors Worldwide •

Cleveland, Ohio 44117-1199 U.S.A. TEL: 216.481.8100 FAX: 216.486.1751 WEB SITE: www.lincolnelectric.com