

## TABLE OF CONTENTS

CUSTOMER MESSAGE	Inside Front Cover
SAFETY PRECAUTIONS	3
GENERAL DESCRIPTION	6
SPECIFICATIONS	7
MAINTENANCE	9
OPERATION	18
CUTTING SPEEDS	30
TOOL BITS	31
CLAMPING PAD SETS	39
TROUBLE SHOOTING	40
ACCESSORIES	43
ILLUSTRATED PARTS BREAKDOWN	44
TOOL BIT RESHARPENING POLICY	Inside Back Cover
WARRANTY INFORMATION	Inside Back Cover

Copyright 2005

Proprietary property of TRI TOOL Inc.

No reproduction, use, or duplication of the information shown hereon is permitted without the express written consent of TRI TOOL Inc.

## SAFETY PRECAUTIONS

### IN GENERAL

When using rotating head cutting equipment, basic safety precautions should always be followed to reduce the risk of personal injury.

Operate this tool only in accordance with specific operating instructions.

#### **WARNING:**

Do not override the deadman switch on the power unit. Locking down, obstructing, or in any way defeating the deadman switch on the power drive unit may result in serious injury.

### DRESS CONSIDERATIONS

Use standard safety equipment. Hard hats, safety shoes, safety harnesses, protective clothes, and other safety devices should always be used when appropriate.

Use safety glasses. Do not operate cutting tools without eye protection.

Dress properly. Do not wear loose clothing or jewelry. They can be caught in rotating and moving parts. Avoid slippery floors or wear nonskid footwear. If you have long hair, wear protective hair covering to contain it.

### WORK AREA

Keep the work area clean. Cluttered work areas and benches invite injuries.

Consider the work area environment. Keep the area well lit. Keep electrical cords, cables, rags, rigging straps, and etc. clear of rotating equipment. Do not use power-cutting tools in the presence of flammable liquids and gasses.

Keep visitors away. Do not let visitors or untrained personnel at or near operating tools. Enforce eye protection requirements for all observers.

Do not over reach. Keep proper footing at all times.

Stay alert. Watch what you are doing. Use common sense. Do not operate tools when you are tired.

### **TOOL CARE**

Maintain tools with care. Keep tools in good operating condition. Sharp tool bits perform better and safer than dull tool bits. Well maintained tools function properly when needed.

Check for damaged parts. If a tool has malfunctioned, been dropped or hit, it must be checked for damage. Run no-load tests and feed function checks. Do a complete visual inspection.

Electric motors. Use only with proper AC voltage power sources and observe all normal electric shock hazard procedures.

Do not abuse power and control cords. Pulling or running over cords and cables can result in electrical shock hazards and malfunctions. Keep control and power cords out of all cutting fluids and water.

Hydraulic drives. Observe proper procedures for electrically driven power sources. Avoid damage to hydraulic lines. Keep quick-disconnects clean. Grit contamination causes malfunctions.

Air tools. Check the exhaust muffler. Broken or damaged mufflers can restrict air flow or cause excessive noise. Use air motors only with a filtered, lubricated and regulated air supply. Dirty air, low-pressure air or over pressure air will cause malfunctions, including delayed starting.

### **AREA EQUIPMENT**

Secure work. Whenever possible use clamps, vises, chains and straps to secure pipe.

Make sure the tool is secured; it is safer to have both hands free to operate the tool.

### **TOOL USE**

Use the right tool and tool bit for the job. Do not use a tool, which is incorrect for the job you are doing.

Keep the tool bits fully engaged in the tool bit holders. Loose bits are a safety hazard.

Disconnect power supply during setup and maintenance. Use all 'Stop' or Shut off' features available when changing or adjusting tool bits, maintaining the tool, or when the tool is not in use.

Remove adjusting keys and wrenches before applying power to the equipment. Develop a habit of checking the tool before turning it on to make sure that all keys and wrenches have been removed.

Do not force tools. Tools and tool bits function better and safer when used at the feed and speed rate for which they were designed.

Do not reach into rotating equipment. Do not reach into the rotating head stock to clear chips, to make adjustments, or to check surface finish. A machine designed to cut steel will not stop for a hand or an arm.

Handle chips with care. Chips have very sharp edges and are hot. Do not try to pull chips apart with are hands; they are very tough.

Avoid unintentional starts. Do not carry or handle tools with your hand on the operating switches or levers. Do not lay the tool down in a manner that will start the drive. Do not allow the tool to flip around or move when adjusting or changing tool bits.

Store idle tools properly. Disconnect tools from the power source and store in a safe place. Remove tool bits for safe handling of the tool.

## **GENERAL DESCRIPTION**

The Model 630SB Low-Profile Clamshell (P/N 01-1525) is a split-frame pipe lathe designed for severing and beveling in-line pipe with a minimum range of 26" through 30" pipe with minimal radial and axial clearance.

Using standard Tool Blocks the Model 630SB may be configured to perform the following operations:

- Sever in-line pipe.
- Sever and bevel in-line pipe.
- Sever and double bevel in-line pipe.

## **DESIGN AND OPERATING FEATURES**

The easily adjustable precision bearing surfaces pre-load and stabilize the rotating head to provide long life, low maintenance, stability, and precision.

The Clamshell splits into two halves for mounting on closed loop systems.

All parts are secured to the two halves, thus avoiding the loss of parts and at the same time providing maximum ease of handling.

The Clamshell is equipped with Adjustable Clamping Pads and Jackscrews for out-of-round pipe conditions.

Dual Tool Blocks with Auto-feed Sprockets and Adjustable Slides provide maximum maintainability, life, and operator safety, with a minimum of operator training.

The Auto-feed Sprockets provide .004" (.10 mm) of radial feed per revolution of the Headstock for a controlled depth of cut.

The drive gears and bearing surfaces are covered for operator safety and are sealed to provide protection from dust and chips.

The operator's controls are located away from the rotating Headstock for the operator's safety.

A modular design concept provides quick, easy maintenance and maximum versatility in the drive and tooling options.

Two detachable right angle Air Motors provide maximum handling ease and low axial clearance.

## SPECIFICATIONS

Model 630SB with the standard Air Motors.

Weight: 486 lbs. (220 kg) without the Air Motors attached.

Power Requirements: 150 cfm at 90 psi with standard Air Motors  
(71 lt/sec at 6.3 kg/cm<sup>2</sup>)

### Envelope, Model 630SB, Air, Clamshell

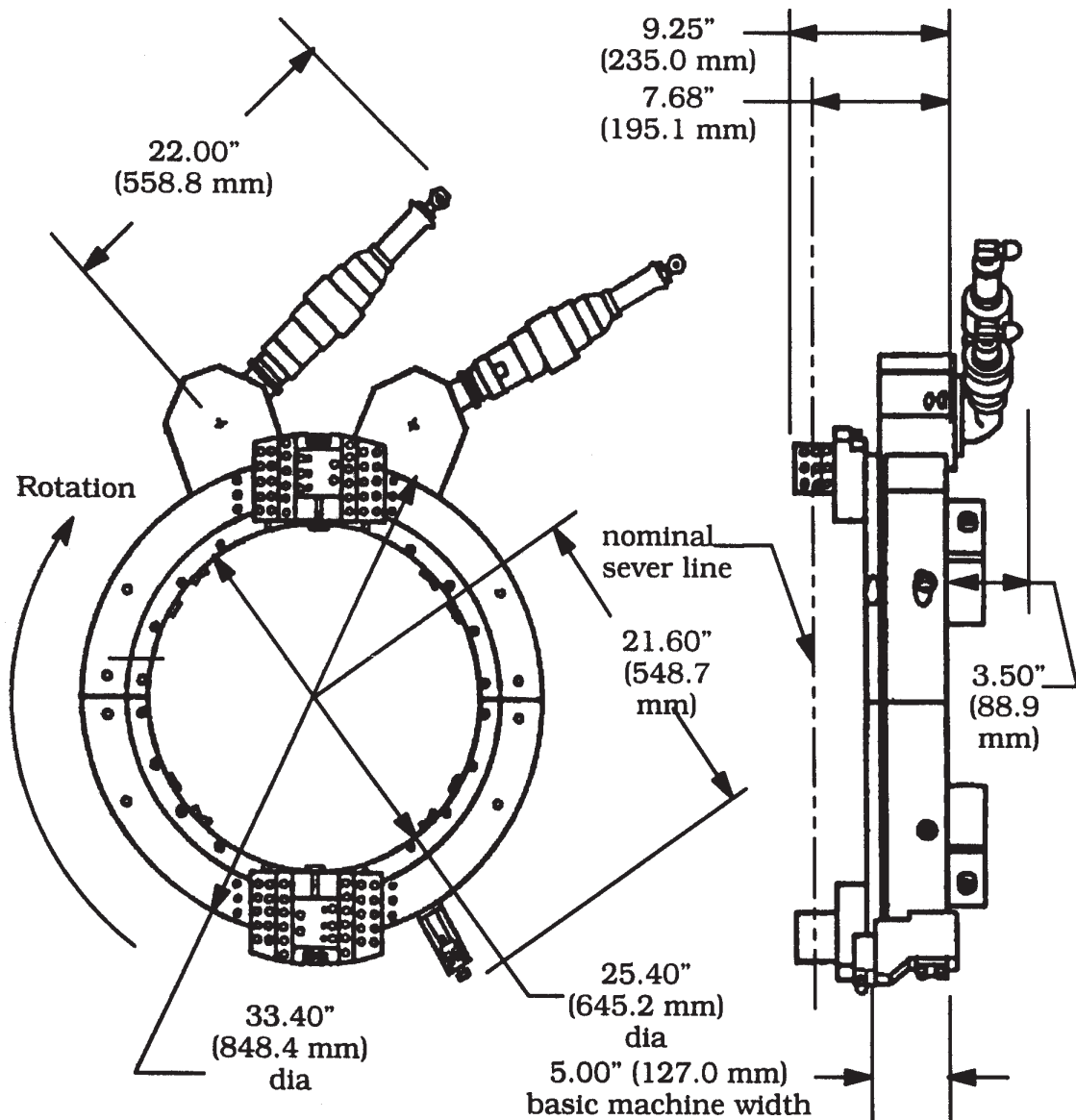

<b>CUTTING CAPACITIES ON 26" THROUGH 30" PIPE</b>	
<b>Note: Capacity may exceed the maximum wall thickness for small pipe sizes</b>	
Severing with standard procedures	2.50" Wall (63.5 mm)
Severing and single beveling	1.25" Wall (31.8 mm)
Severing and double beveling	1.25" Wall (31.8 mm)
Severing and beveling with special procedures	2.00" Wall (50.8 mm)

<b>CLEARANCES</b>	
Rotating parts diameter	43.50" (1104.9 mm)
Main Frame diameter	39.50" (1003.3 mm)
<b>Axial clearance required relative to center-line of the cut:</b>	
Mounting side	7.68" (195.1 mm)
Side opposite of the frame	1.56" (39.6 mm)

<b>Radial Clearance Over The Pipe or Tube</b>		
<b>Pipe Size</b>	<b>Clearance Tool Blocks</b>	
30"	6.75"	171.5 mm
28"	6.75"	171.5 mm
26"	6.75"	171.5 mm



## MAINTENANCE

All components should be cleaned and coated with a light film of oil prior to use. Use a clean, non-detergent oil, preferable SAE 10 (90 SSU or lighter).

Air supply for the Model 630SB Clamshell with dual Air Motors requires an adequate filter/regulator/lubricator (FRL) to be used.

**NOTE:**

The Motor warranty is void if damage occurs from contaminated air or lack of lubrication.

### Clean Up

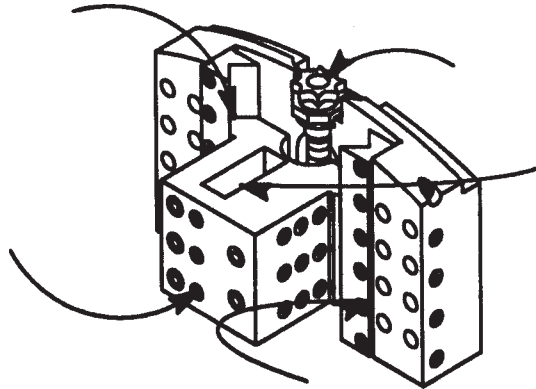

If the Clamshell is operated in such a manner that the Tool Blocks collect debris while cutting, the Tool Blocks and the Feed Screws should be cleaned after each cutting operation.

### RECOMMENDED MAINTENANCE SCHEDULE

Daily maintenance when the unit is in operation:

Wipe the unit down and spray with rust preventative under severe humidity conditions.

Visually inspect for loose screws, missing screws, damage, etc.

After every 20 hours of actual operation:

Check adjustment of the Main Bearings pre-load.

Lubricate the male and female Tool Block Slides and the Feed Screw. (Refer to 'Tool Block Maintenance' located later in this section.)

After every 40 hours of actual operation:

Thoroughly clean and lubricate Main Gear, Drive Gear, male and female Tool Slides, Feed Screws, and Tripper Block Assy.

Non-scheduled maintenance:

Readjust the Main Bearings pre-load if the Clamshell generates excessive heat or if the Main Bearings becomes loose. (Refer to 'Adjustment of the Main Bearings pre-load' later in this section.)

Thoroughly clean and check the Tool Blocks in the event of feed problems.

### STORAGE

If the Clamshell is to be stored or if it will remain out of service for a significant period of time (30 days or more), it should be thoroughly cleaned, lubricated and sprayed with a rust preventative prior to storage.

Remove the airline Quick Disconnect and spray it with a light-weight oil.

Squirt oil into the male Quick Disconnect.

Reconnect the airline and turn on the Air Motor for 1 or 2 seconds to disperse oil throughout the vanes and rotor.

### ADJUSTMENT OF THE MAIN BEARINGS PRE-LOAD

Loosen all Bearing Adjustment Lock Screws about 1/2 turn (1 through 24).

Turn in Bearing Adjustment Screws (1, 5, 9, 13, 17, and 21) so that they are snugged tightly.

This insures that the Bearings are fully pushed forward. (Refer to the 'Bearings Adjustment Screw locations'.)

Lightly turn in the remaining Bearing Adjustment Screws in the order shown until all of the Bearings make contact with the Headstock.

Relax Bearing Adjustment Screws (1, 5, 9, 13, 17, and 21) and resnug them so that all of the Bearing Adjustment Screws are evenly loaded against the Bearings.

Connect the air supply and apply power to the Clamshell so that it is running at full speed.

### Bearing Adjustment Screw Locations

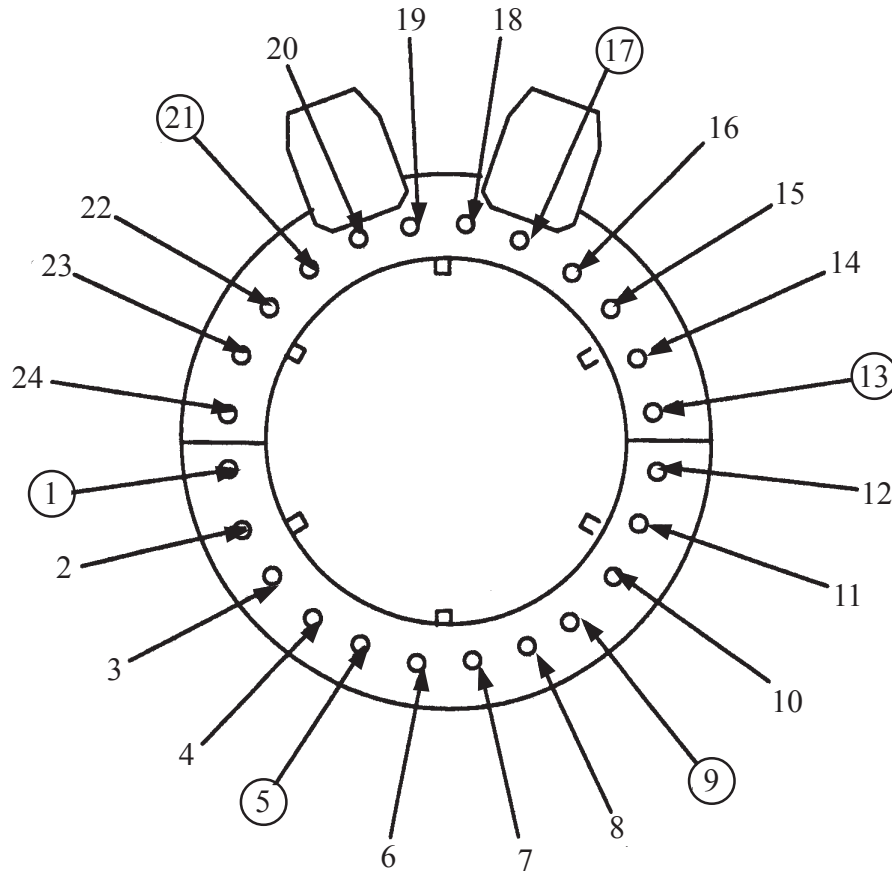

Adjust the Bearing Adjustment Screws (1 through 24) so that the Clamshell rotation slows slightly.

Listen for a change in the sound of the Air Motors.

Adjust the Bearing Adjustment Screws in small increments so that the Bearings are loaded evenly.

All of the Bearing Adjustment Screws should be snugged to ensure that the Bearings are uniformly loaded.

The safe torque range on the Bearing Adjustment Screws is 1 to 3 in-lbs.  
(.1 to .3 N-m).

Over-tightening the Bearing Adjustment Screws will result in accelerated bearing wear and lower available power.

Lock the Bearing pre-load by tightening the Bearing Adjustment Lock Screws (1 through 24).

The safe torque should be 8 to 10 ft-lbs. (11 to 14 N-m).

**WARNING:** Too much torque may crack the Bearing while too little torque may allow the Bearing pre-load to relax.

**INSPECTION OF THE MAIN GEAR**

If the Headstock does not run smoothly, even after adjustment, inspect the Main Gear to insure that no chips, dirt or dust have damaged the gear.

Remove the front Thrust Plates by removing the forty (40) Hold Down Screws.

Lift the Headstock from the Housing. (Refer to the Clamshell Cross Section.)

The Main Gear and the Main Bearings may now be inspected.

Check the Bearings, Housing, and the race on the Gear.

All surfaces should be smooth, without scratches, and they should feature even wear patterns over the entire surface.

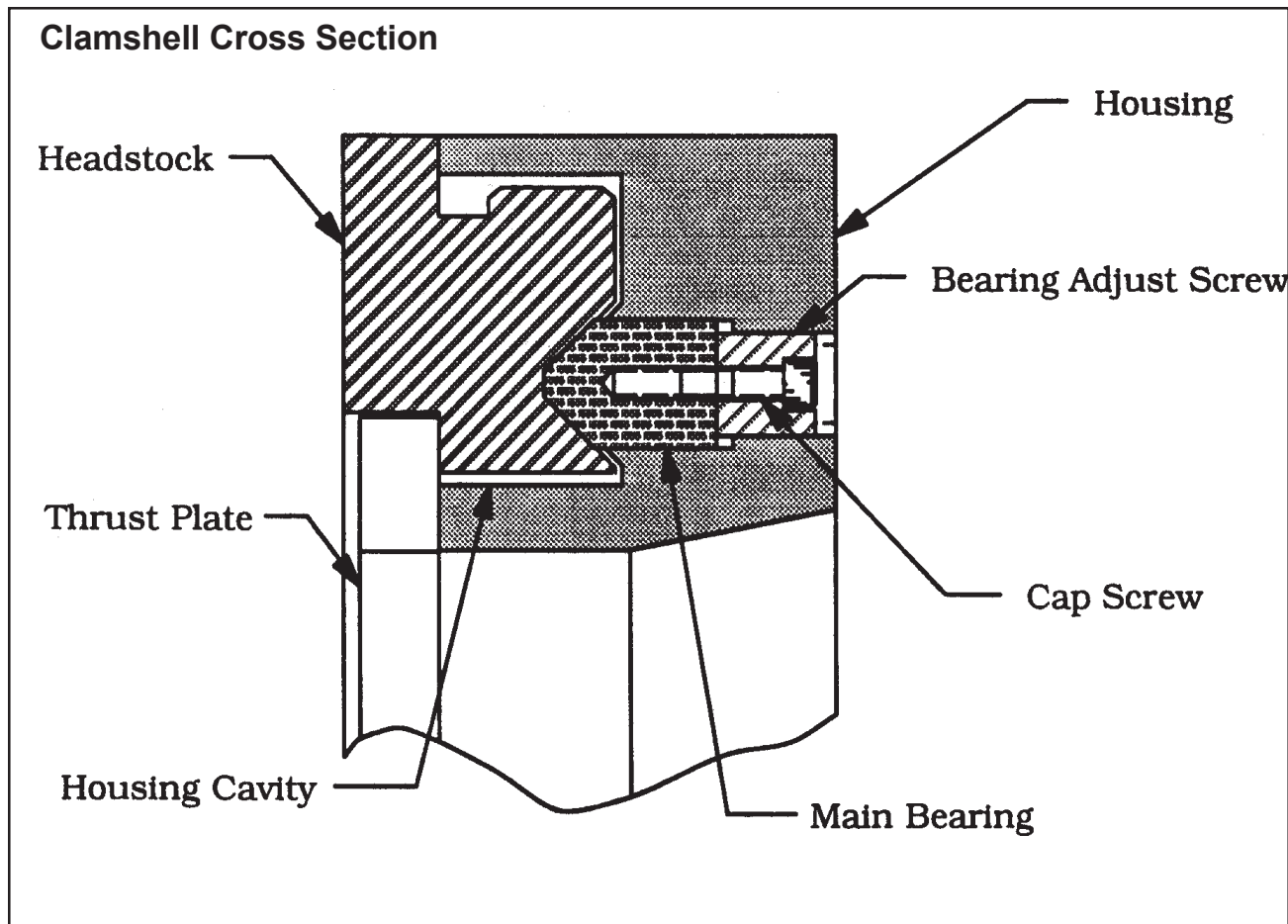

## Model 630SB Low Profile Clamshell, Air

Check the Housing cavity for chips, dirt and/or corrosion.

To reassemble, wipe clean all of the Bearing surfaces and clean the Housing cavity.

Regrease the Gear using a lubricant approved by TRI TOOL Inc. (Refer to 'Lubricant Recommendations' located later in this section.)

Place the Headstock carefully back into the Housing.

Bolt the Front Thrust Plates back into place.

If the bearing pre-load was properly adjusted before disassembly, then it will still be adjusted when reassembled.

### DRIVE GEAR AND MAIN GEAR LUBRICATION

Remove the Drive Housings.

Inspect both Drive and Main Gears for chips or burrs and clean as required.

Coat the teeth of the Drive Gear and the Main Gear with a grease which is approved by TRI TOOL Inc.. (Refer to 'Lubricant Recommendations' located later in this section.)

### TOOL BLOCK MAINTENANCE

Clean the Slide Rails, the Feed Nut, the Sprocket Assy. and the Feed Screw.

Inspect these parts for damage and replace as required.

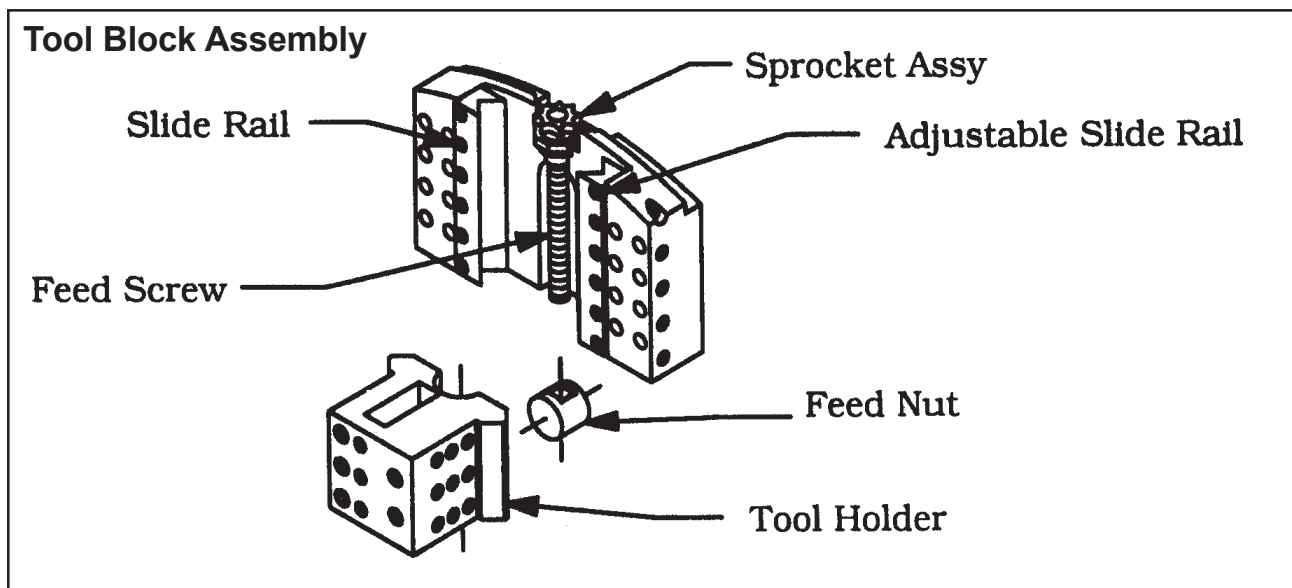

Lubricate and reassemble the Tool Block. (Refer to the picture 'Tool Block Assembly'.)

**NOTE:** Use lubricant on the Feed Screw sparingly or wipe to a film condition.

Excess lubricant will collect grit and/or chips and tend to cause thread jamming and/or damage.

Adjust the Adjustable Slide Rail to provide a firm, but not excessive rotational pressure on the Sprocket.

The Slide Rails must be over-tightened to squeeze the oil into a thin film against the male and female surfaces of the Slide Rails.

Reset for proper operation.

**NOTE:** If the Mounting Bracket has been overstressed, the Slide Rails may appear to loosen when mounted if they were adjusted off of the Clamshell.

Adjustment when mounted provides the most satisfactory results.

#### TOOL HOLDER ADJUSTMENT

Loosen the Hold-down Screws on the Adjustable Slide Rail.

Run the Tool Holder to the most outward position.

Using the Adjustment Set Screws, apply a light force to the side of the Adjustable Slide Rail so that it is in positive contact with the Tool Holder.

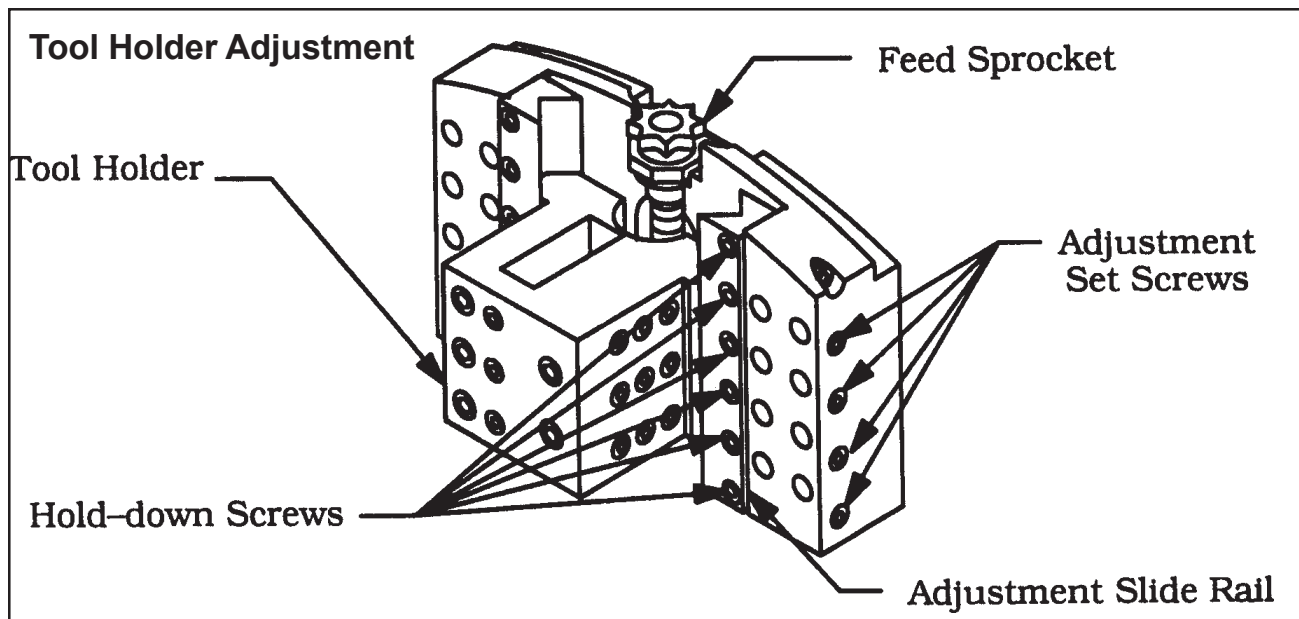

Adjust only those screws, which bear directly in line with the Tool Holder.

Tighten the Hold Down Screws to about 12 to 24 in-lbs. (1.4 to 2.7 N-m). (Finger tight using a hex key)

Using the Spanner Wrench, run the Tool Holder to the inward most position.

Note any changes in the feed pressure.

Adjust the remaining Adjustment Set Screws so that the Tool Holder has a smooth, even feel.

Run the Tool Holder the full length of the Slide Rail.

Tightly lock the Adjustable Slide Rail in place with the Hold-down Screws and fully snug the Adjustment Set Screws.

Check that the Tool Holder runs smoothly and evenly for the full length of travel.

Readjust as necessary.

The Tool Holder should move snugly.

In general, when the Slide Rail is set correctly, the Feed Sprocket cannot be turned by hand but may be turned easily with the Spanner Wrench.

The torque on the Spanner Wrench should be about 2 to 5 ft-lbs. (3 to 7 N-m).

### AIR MOTOR LUBRICATION

No direct maintenance is normally required on the Air Motors.

However, the air supply must flow through a filter/regulator/lubricator (FRL) unit or separate units before arriving at the motor.

The FRL unit must be maintained as required (frequency dependent on the basic air supply) to keep the water trap drained, filter cleaned and the lubrication oil reservoir filled so that a drop of oil every 2 to 5 seconds is flowing.

If the Clamshell is to be left idle for 24 hours or more after being run on 'wet' air, it is advisable to squirt oil directly into the motor inlet and run the motor for 2 to 3 seconds.

This will prevent rusting and 'freezing' of the rotor vanes.

TRIPPER BLOCK ASSY LUBRICATION AND TRIPPER SHAFT ADJUSTMENT

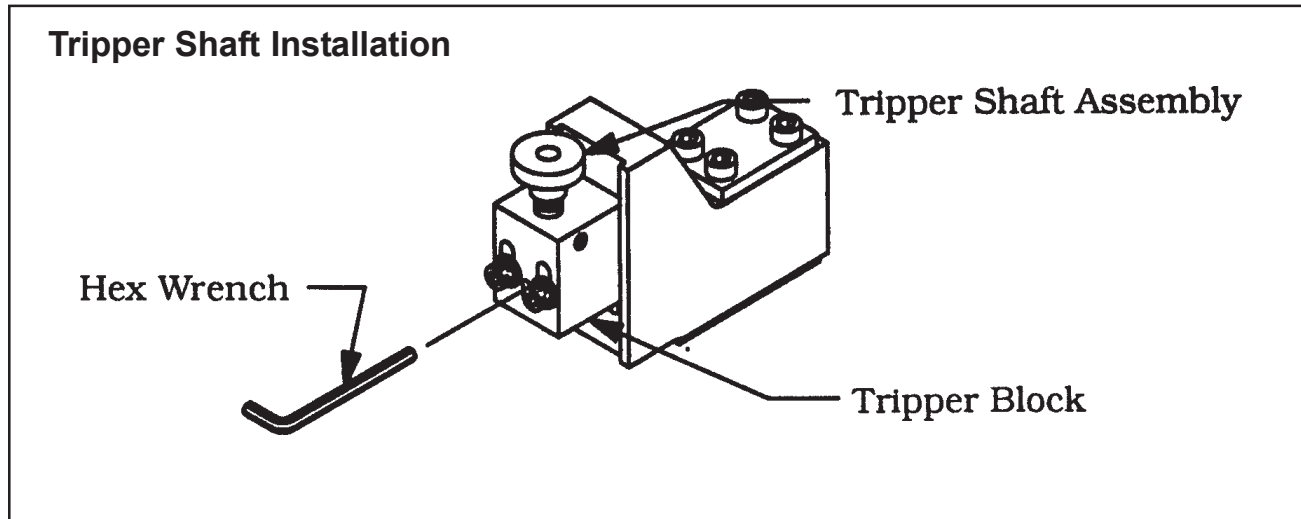

Back off the Half Dog Set Screw until it disengages from the Tripper Shaft. (Refer to the Tripper Shaft installation.)

Remove the Tripper Shaft Assy from the Block and clean off all of the old lubrication.

Apply fresh lubrication to the Tripper Shaft Assy and re-install it in the Block.

Screw in the Half Dog Set Screw until it locates itself in the slot on the Tripper Shaft.

See Operating Instructions later in the booklet for Feed Pin to Sprocket adjustment.

**LUBRICANT RECOMMENDATIONS**

The Drive Gears require a high string lubrication grease such as “Chevron Utility Grease, light, high string for gears” (P/N 68-0015).

The Slide Rails and Tool Blocks require a light oil such as SAE 10 light machine oil.

The Feed Screw for the Tool Block and the Tripper Block Assy require a SAE 10 light machine oil for normal conditions and under dusty conditions a silicone, graphite or molybdenum disulfide ‘dry’ lubricant.

**NOTE:** A light film of all-purpose grease may be used, but it must be checked for grit contamination frequently.

The Air Motor requires a Class 2 lubricant, viscosity of 100 to 200 SSU at 100° F (38° C) minimum aniline point of 200° F (93° C).



**TRI TOOL Inc. – Air Tool Lubricant (P/N 68-0022)**

AMOCO – American Industrial Oil No. 32

Atlantic Richfield – Duro Oil S-150

Chevron – A.W. Machine Oil 32

Exxon – Nuto H32

Shell – Tellus Oil 32

The Bearings in the Air Motor are sealed and do not require any lubrication.

## OPERATION

Read the operation instructions carefully before attempting to operate the Model 630SB Low Profile Clamshell.

Configure the Clamshell for the specific task required.

Mount the Tool Blocks and Tripper Bracket onto the Clamshell.

Select and install the proper Clamping Pad Set into the Clamshell. (Refer to the section on 'Clamping Pad Sets' later in this booklet.)

Do not install the Tool Bits until the Clamshell has been installed on the pipe.

### INSTALLATION OF THE CLAMSHELL ON AN IN-LINE PIPE

Separate the two halves of the Clamshell.

Disengage the Air Motors by removing the Motor Hold-down Bolts and removing both of the Air Motors from the drive sockets.

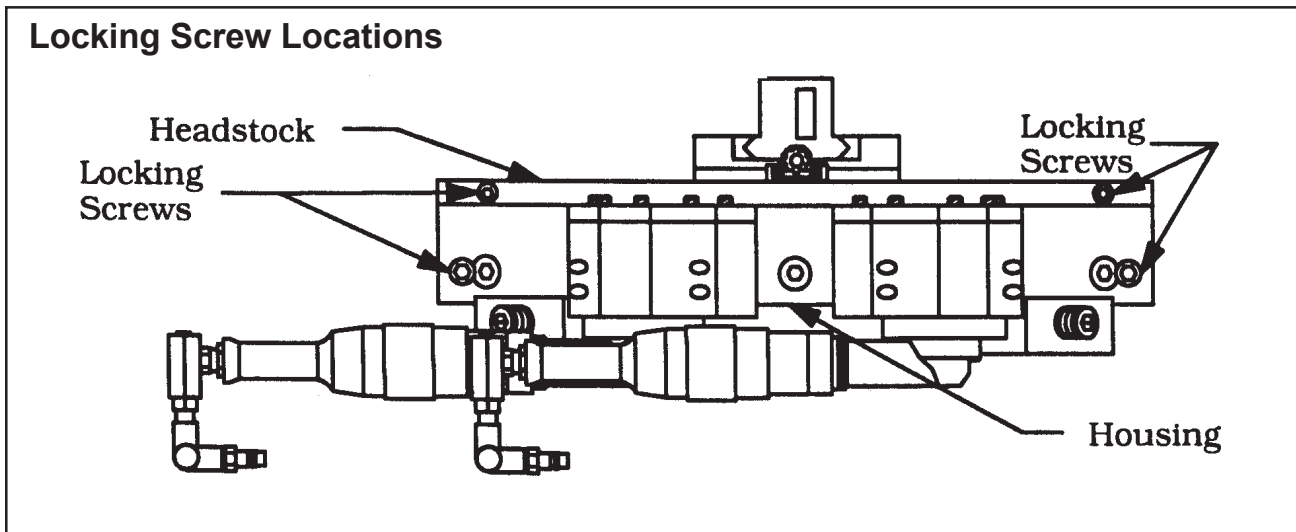

Rotate the Headstock until the split-lines of the Headstock match the split-lines of the Housing.

Fasten the four Lock Blocks from the Headstock to the Thrust Plate on each half of the Clamshell.

Unbolt the two halves of the Clamshell.

Two Locking Screws are located on the Housing and two more on the Headstock. (Refer to 'Locking Screw locations'.)

These Locking Screws are captured in their holes so that they will not come totally free of the Clamshell.

Separate the Clamshell halves evenly by pulling straight apart.

**DO NOT FORCE OPEN.**

### SECURE THE CLAMSHELL TO THE PIPE.

Clean the mating surfaces and the contact surface of the Mounting Pads and the Jackscrews on each half of the Clamshell.

Wipe clean the mounting surface of the pipe.

Check to insure that the Tool Blocks will clear the pipe when the Clamshell is mounted.

Close the two halves of the Clamshell around the pipe, keeping the mating surfaces clean.

Check that the Alignment Pins have seated the two halves properly.

Bolt the two halves of the Clamshell together using the Locking Screws in the Housing and in the Headstock.

Tightening torque should be 50 to 60 ft-lbs. (68 to 81 N-m).

Loosen the Lock Blocks, rotate and refasten them to the Headstock.

Using the fully Adjustable Clamping Pads, clamp the Clamshell to the pipe as follows:

Rough center and square the Clamshell by tightening the four Clamping Pads independently.

Check the center and squareness by eye.

The Adjustable Pads tend to square the Clamshell to the pipe.

If additional precision in squaring is required, consult TRI TOOL Inc. about alternate methods of squaring.

Fine center the Clamshell as you would a 4-jaw chuck.

Take measurements from the pipe OD to the Housing ID or use a dial indicator to sweep around the pipes outside diameter.

Adjust the four Clamping Pads so that the measurements at opposing Clamping Pads are the same.

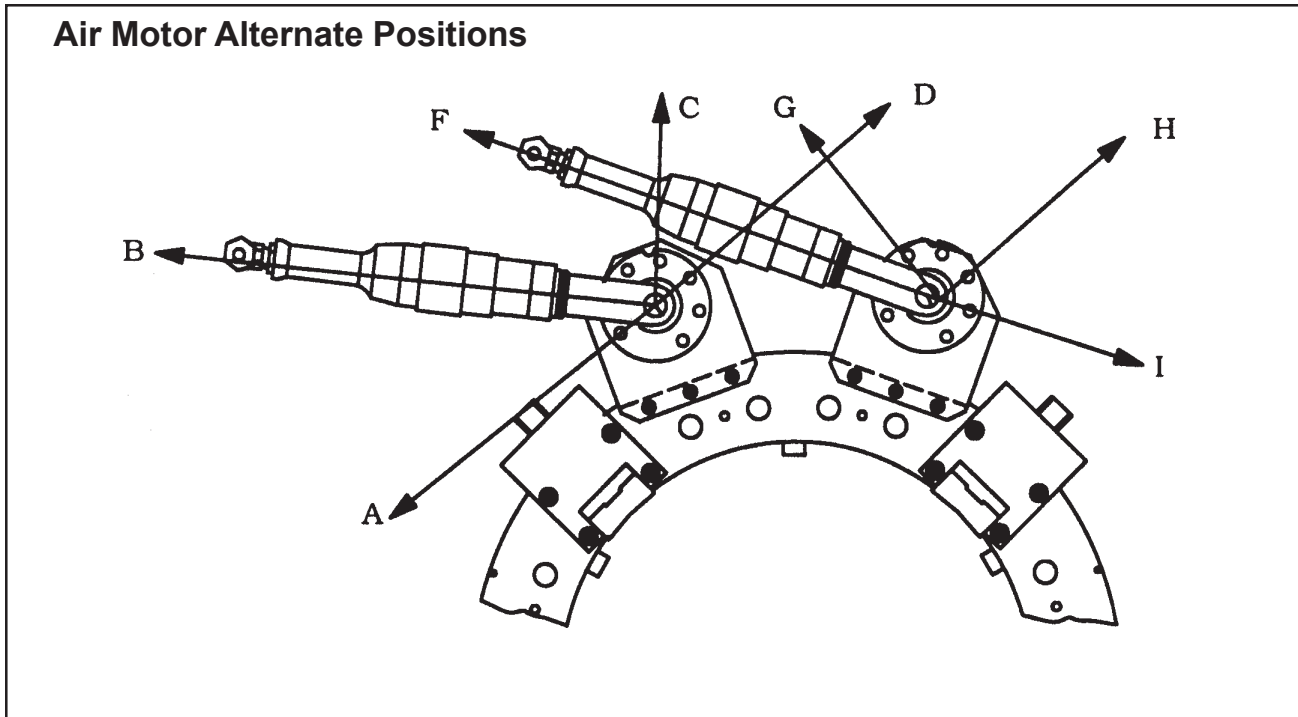

Tighten the Clamping Pads using a tightening torque of 50 to 75 ft-lbs. (68 to 102 N-m).

Tighten the Jackscrews against the pipe using a tightening torque of 35 to 50 ft-lbs. (47 to 68 N-m) for added stability.

#### GENERAL MACHINING SEQUENCE

There are 4 various orientations available for each Air Motor so that clearance for the Air Motors may be obtained. (Refer to the Air Motor alternative positions.)

Install the Air Motors into the Drive Sockets and bolt them to the Clamshell.

**CAUTION:** The Motor Mount reacts the torque of the Air Motor only when the Motor Hold-down Bolt is in place.

**NOTE:** Check that the air supply filter/regulator/lubricator is installed and set properly.

Rotate the Headstock slowly with the Tripper Shaft pushed 'in' for one full revolution to insure that the Feed Pin to Sprocket is set right on both Tool Blocks. (Refer to the Approach of the Feed Pin to the Feed Sprocket.)

**WARNING:** You will break the Feed Pin if the Feed Pin to Sprocket alignment is incorrect.

To check the Feed Pin to Sprocket engagement go to 'Feed Pin to Sprocket engagement' later in this section.

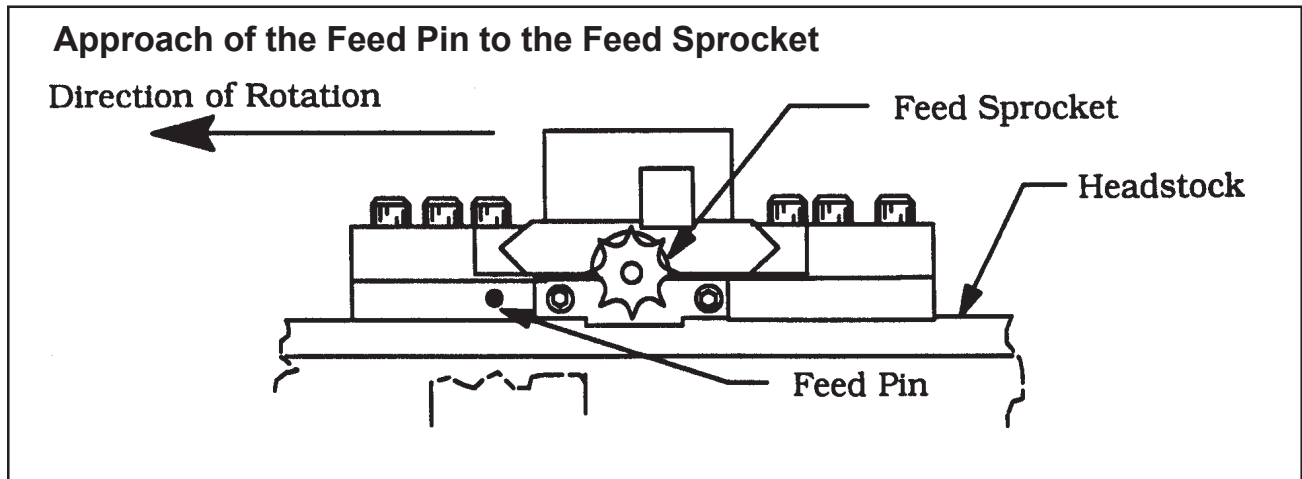

Select and install the desired Tool Bit Set.

Refer to 'Tool Bit Set up' later in this section for selection and set-up instructions.

Turn the Air Motors on to full speed by opening the Throttle Control Valve.

**NOTE:** The Air Motor working speed will be about one half of the no-load speed. (Refer to 'Cutting Speeds' later in the booklet, for speed selection chart.)

Engage the feed by pushing the Tripper Shaft in.

Monitor the cutting operation.

Apply cutting fluid as necessary.

If chips build up so much that they tangle in the Clamshell, disengage the feed for 2-3 revolutions to clear the chip.

Then stop the Clamshell and remove the chips.

Refer to 'Severing' later in this section for specific machining procedures.

**CAUTION:** In-line pipe stores energy.

When the pipe is severed, the pipe may move.

To prevent accidents due to the spring in the pipe system, be sure to secure the pipe on both sides of the sever line in order to prevent differential movement of the pipe ends.

When the machining operation is finished, disengage the Feed Pin by pulling the Tripper Shaft to the 'out' position.

Allow the Headstock to continue for 3 revolutions to complete the cutting operation.

Turn off the Air Motors by closing the Throttle Control Valve.

Retract the Tool Holders so that the Tool Bit(s) clear the pipe OD.

**NOTE:**

The Tool Holders are retracted by rotating the Feed Sprocket clockwise using the special Spanner Wrench supplied with the Clamshell.

Run the Air Motors until the split-lines of the Headstock and the Housing match.

Loosen the Clamping Pads and Jackscrews.

Remove the Clamshell from the pipe.

If the Clamshell must be split to remove it, refer to 'Installation of the Clamshell on an in-line pipe', earlier in this section.

You should have a complete pipe sever at this time.

**FEED PIN TO SPROCKET ENGAGEMENT**

Rotate the Headstock until the Sprocket on the Tool Block begins to approach the Feed Pin.

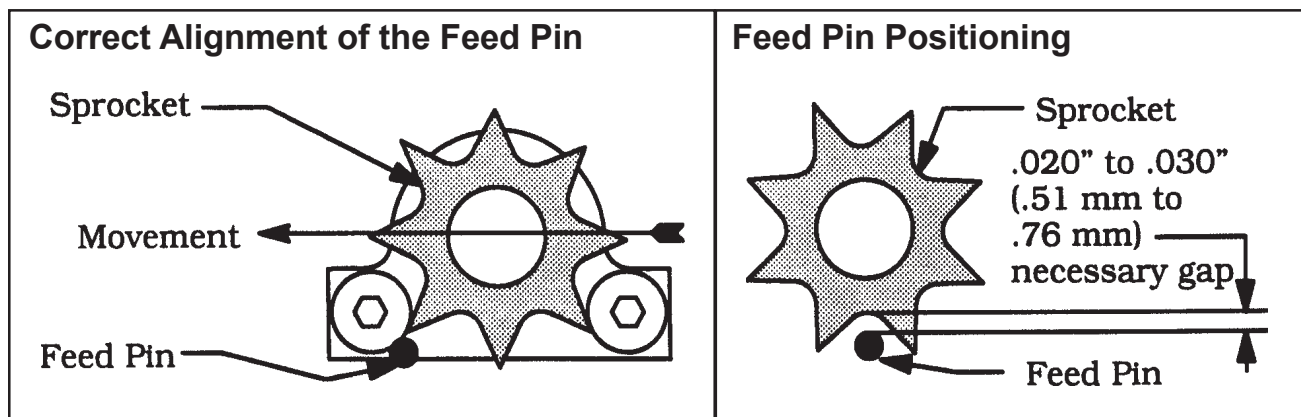

The Feed Pin must not strike the Sprocket Tooth straight on.

This action would damage or break the Feed Pin and/or the Sprocket.

The Feed Pin must strike the Sprocket on the edge of the Tooth.

See the pictures for the correct Feed Pin to Sprocket engagement.

**CAUTION:**

If the Feed Pin to Sprocket engagement is not as shown, operation of the Clamshell may cause serious damage or destroy the Feed Pin and/or the Sprocket.

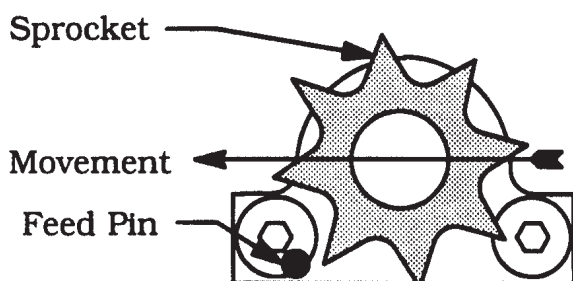
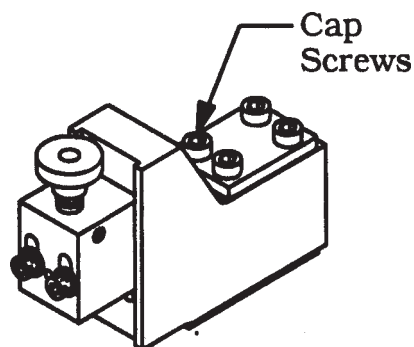
**Incorrect Alignment of the Feed Pin****Tripper Block Adjustment**

If the Feed Pin to Sprocket engagement is as shown in 'Incorrect alignment of the Feed Pin', then it will be necessary to loosen the four (4) Cap Screws on the Tripper Bracket, so that it may be adjusted to the proper gap (.020" to .030" or .5 mm to .8 mm) required for proper engagement.

Go to 'General machining sequence' earlier in this section.

**TOOL BIT SET-UP**

Select the proper Tool Bit set. Refer to 'Tool Bits' later in this booklet.

**WARNING:**

The use of dull or improperly designed Tool Bits or Tool Bits not manufactured by TRI TOOL Inc. may result in poor performance and may constitute abuse of this machine and therefore voids the TRI TOOL Inc. factory warranty.

Install the Tool Bits into the Tool Holders.

**NOTE:**

Refer to the section on Tool Bits for installation drawings of each of the Tool Bit set-ups.

The wall thickness plus 3/4" (19 mm) of Tool Bit should be protruding from the end of the Tool Holder.

Tighten the Tool Bit Set Screws, then verify that there is adequate clearance between the Tool Bits and the pipe by rotating the Headstock.

The Leading Tool Bit should contact the pipe approximately .020" to .040" (.5 mm to 1.0 mm) before the Trailing Tool Bit.

### SEVERING

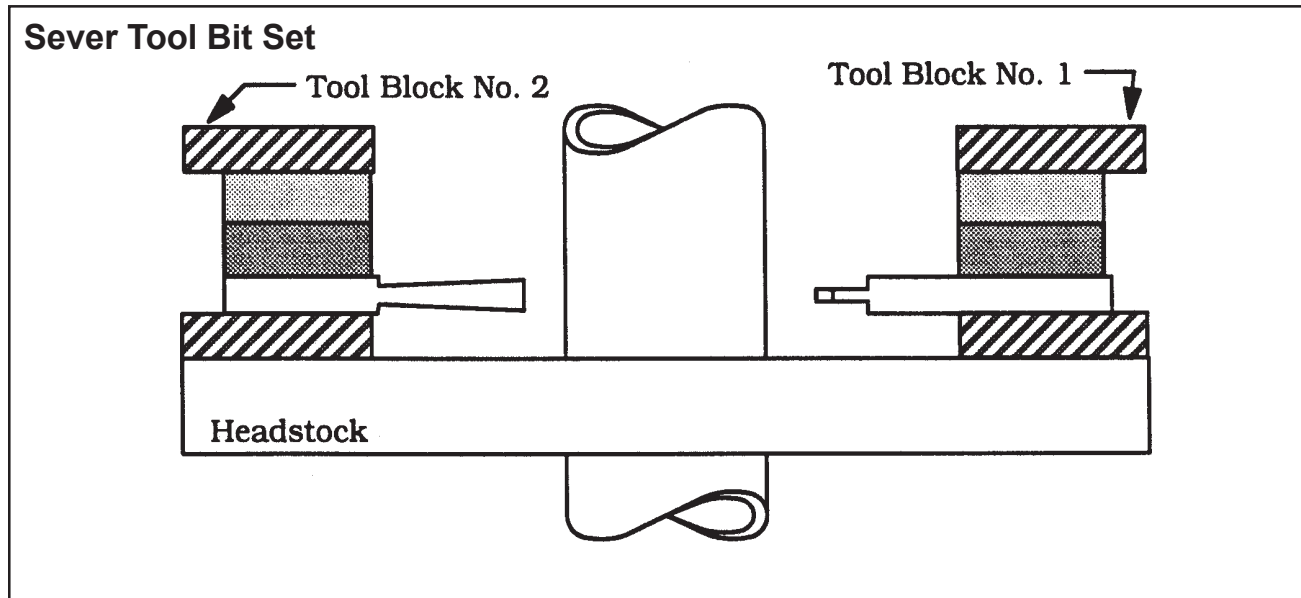

When the Tool Bits sever the pipe, disengage the Feed Pin and let the Headstock rotate 2 to 3 times to clear the chip.

Go back to "When the machining operation is finished..."

### TOOL BIT ADJUSTMENT FOR PART OFF AND DOUBLE BEVEL

Install Tool Bits A, D, and E into Tool Block No. 1 along with two Spacers S3 and S4.

**NOTE:** Either Tool Block may be designated as No. 1.

Position the Spacers flush with the inside face of the Tool Holder.

Position Tool Bits D and E approximately 1/2" (12.7 mm) outward from the cutting edge of Tool Bit A.

**NOTE:** Tool Bits D and E will be repositioned to contact the beveled surface as the cutting progresses.



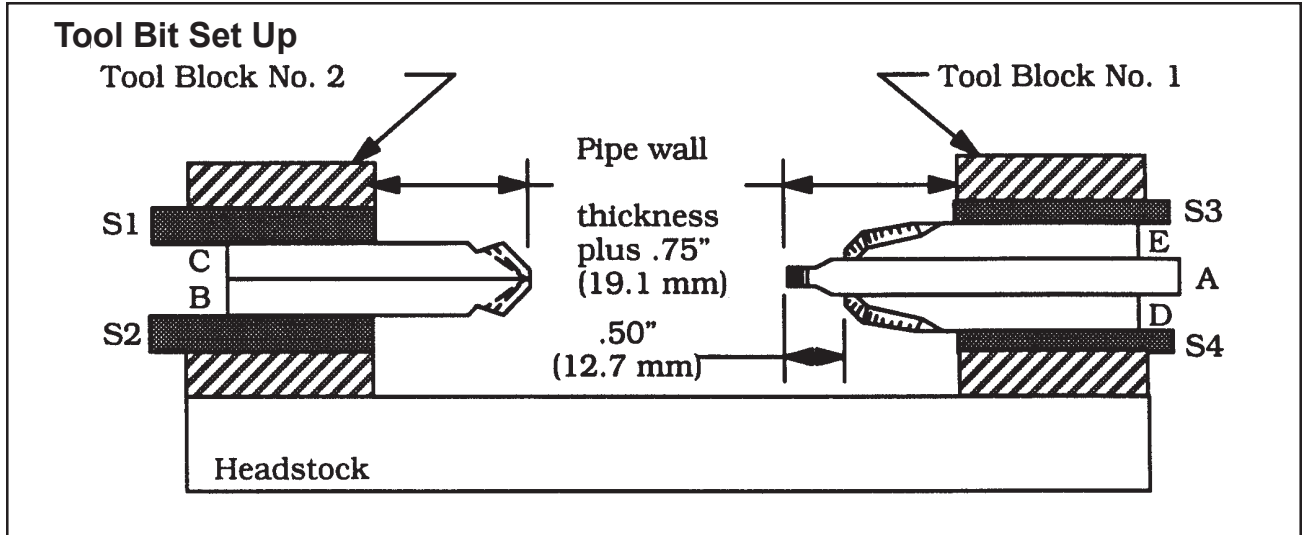

Tighten the Set Screws holding Tool Bits A, D, and E.

Install the Tool Bits B and C into Tool Block No. 2 along with the two Spacers S1 and S2.

Position the Spacers flush with the inside face of the Tool Holder.

Tool Bits B and C should be the same distance inward from the Tool Holder.

Tighten the Set Screws holding Tool Bits B and C.

Set Tool Bit A to lead Tool Bit B and C by the desired land width as follows:

**CAUTION:** Make sure that the Tripper Shaft is in the 'out' position.

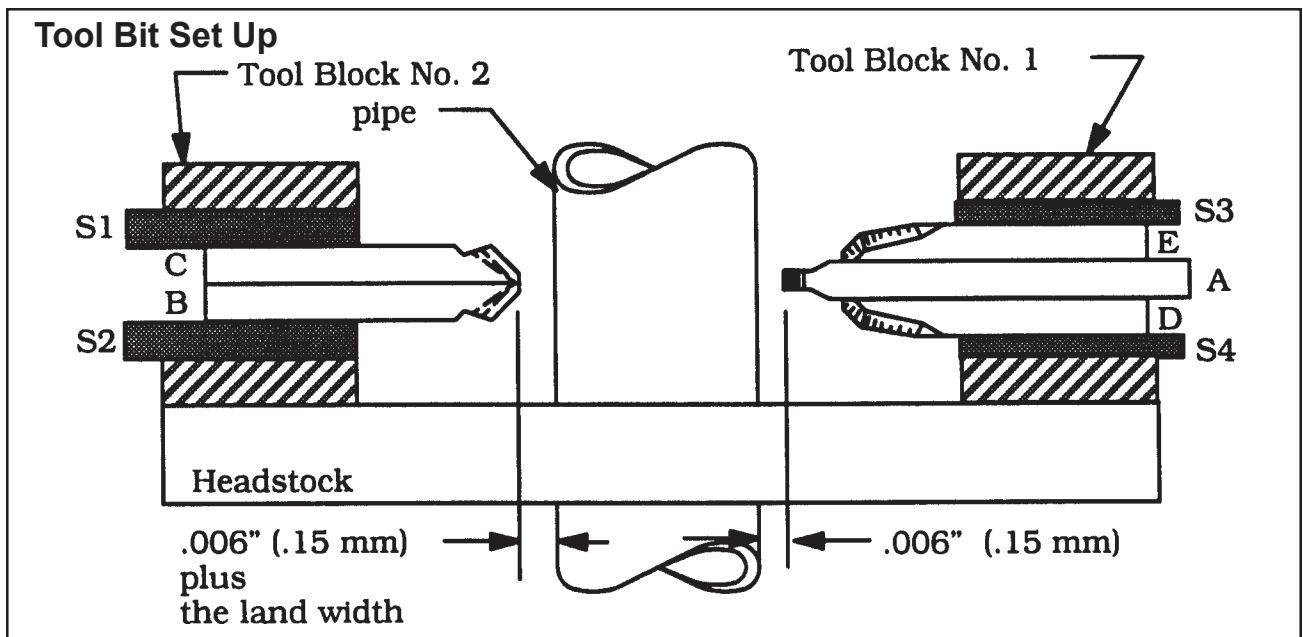

Rotate the Headstock slowly.

While rotating the Headstock, visually determine the point on the surface where Tool Bit A comes closest to the pipe.

Rotate the Feed Sprocket until Tool Bit A makes contact with the pipe.

Back the Tool Holder away from the pipe about 1/4 of a revolution. (approximately .008")(.2 mm).

Each full revolution of the Feed Sprocket moves the Tool Bit .031" (.8 mm) toward or from the pipe.

Continue to rotate the Headstock through 360° slowly, in order to verify that the position of Tool Bit A allows .006" (.2 mm) minimum clearance between Tool Bit A and the pipe surface at the closest point.

Readjust Tool Bit A if necessary.

Mark the pipe surface to define Tool Bit A's closest approach to the pipe.

Continue to rotate the Headstock slowly.

Position Tool Bits B and C directly over the mark that you made to define the closest approach of Tool Bit A to the pipe.

Rotate the Feed Sprocket until Tool Bits B and C make contact with the pipe surface.

Back the Tool Holder off 1/4 revolution of the Feed Sprocket (approximately .008") (.2 mm) plus the desired land width.

Each revolution of the Feed Sprocket moves the Tool Bit .031" (.8 mm) toward or from the pipe.

Engage the Feed Pin by pushing the Tripper Shaft to the 'in' position.

Rotate the Headstock 360° while checking the Feed Pin to the Sprocket engagement.

Initiate the pipe cutting operations.

Go back to "Turn the Air Motors on to full speed..".

RESETTING THE TOOL BITS FOR A BLEND

Loosen the Set Screws holding Tool Bits A, D, and E.

Slide Tool Bits D and E inward until they make contact with the beveled surface formed by Tool Bits B and C.

The pictures below show correct and incorrect blending of the Tool Bit cut.

**CAUTION:** Do not move Tool Bit A.

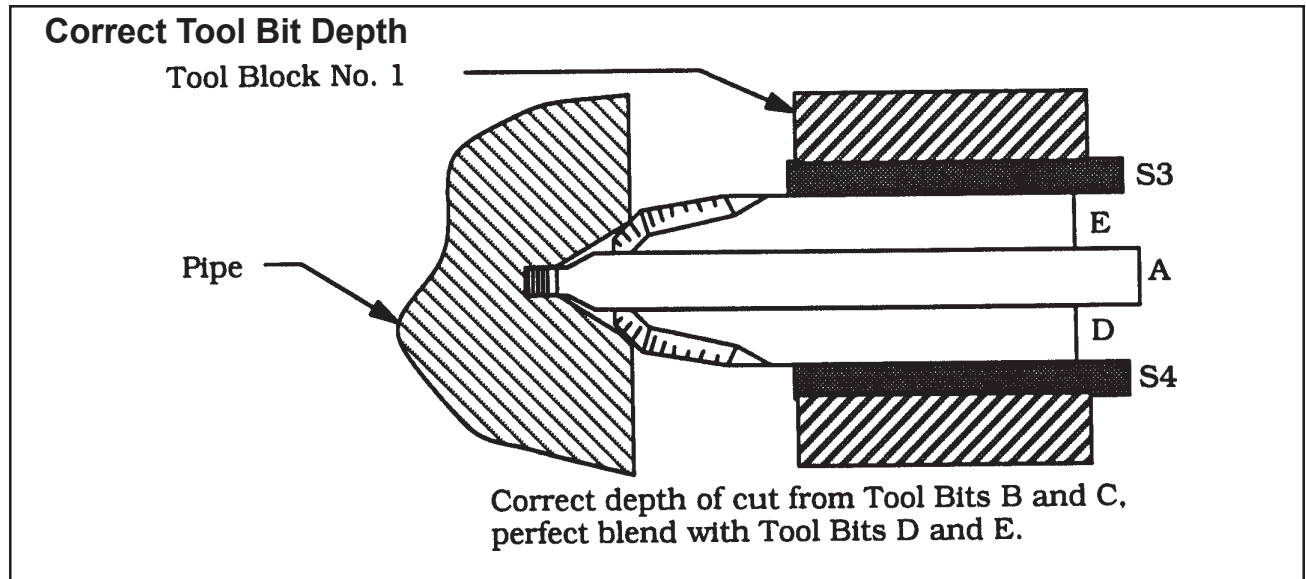

If the cut of Tool Bits B and C is too shallow for a blend with Tool Bits D and E as shown in the picture, then proceed on.

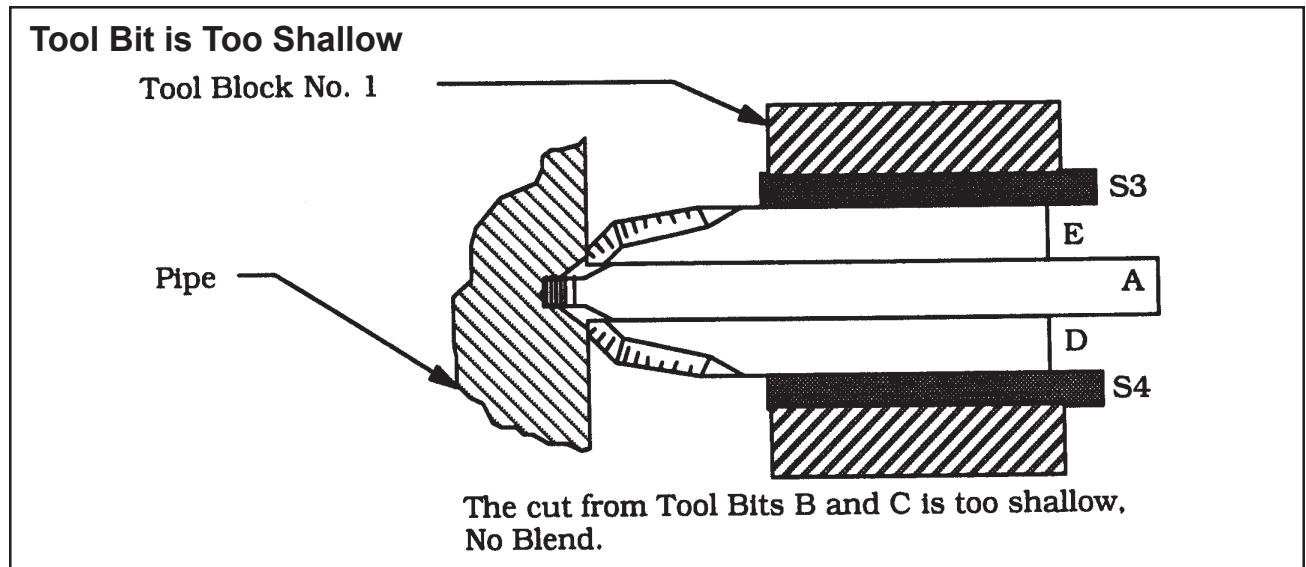

Go ahead to “If too deep a cut has been made....”.

Retract Tool Bits D and E without changing the position of Tool Bit A.

Tighten the Set Screws holding Tool Bits D and E.

Go back to “Turn the Air Motors on to full Speed..”

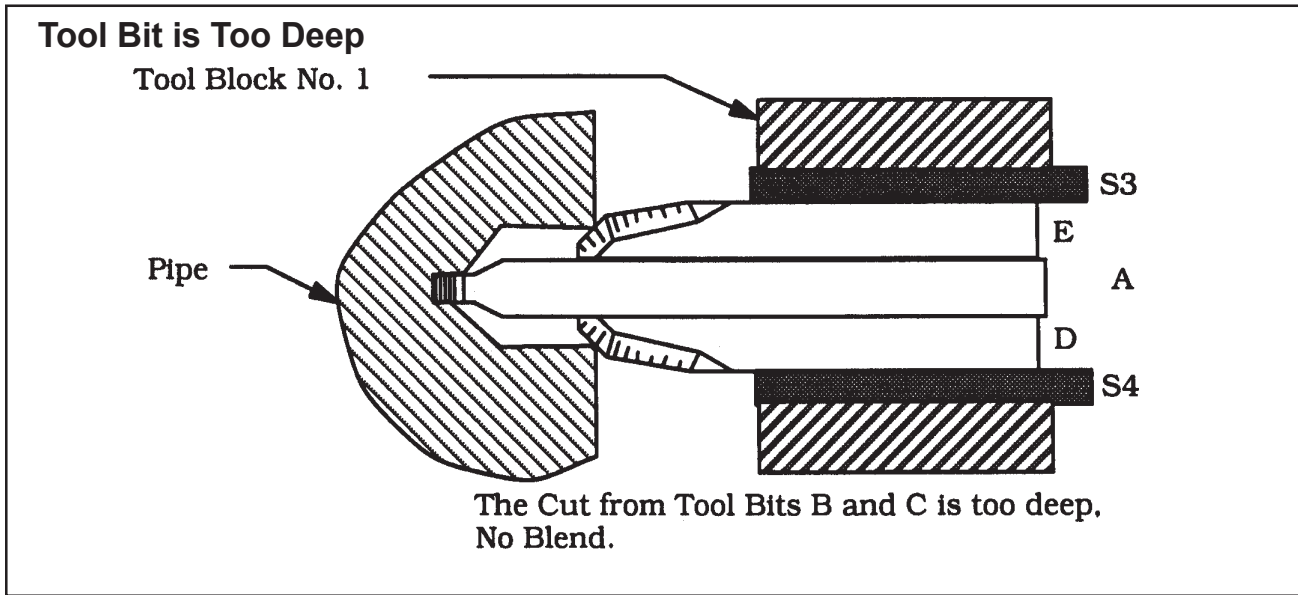

If too deep a cut has been made by Tool Bits B and C as shown, then proceed to “Loosen the Set Screws....”

Go to “Leave Tool Bits D and E in contact....”

Loosen the Set Screws holding Tool Bits A, D, and E.

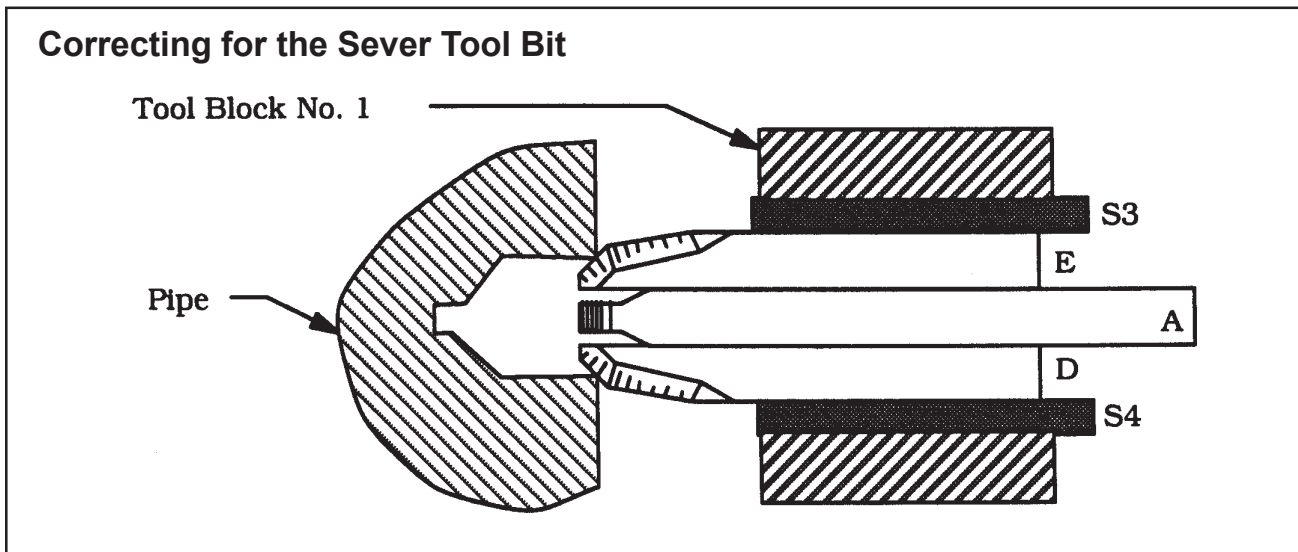

Push Tool Bit A back flush with the ends of Tool Bits D and E, which are in contact with the cut edges made by Tool Bits B and C.

Tighten the Set Screws holding Tool Bits A, D, and E.

Rotate the Feed Sprocket of Tool Block No. 2 clockwise so as to move the Tool Holder away from the pipe cut far enough so that Tool Bits B and C will not cut during this recovery sequence.

**NOTE:**

During this recovery sequence, the only Tool Bits that are to be cutting are Tool Bits D and E so that they may catch up to the bevel made by Tool Bits B and C.

All other Tool Bits must be pulled back from the cutting surface.

**NOTE:**

When a blend has been achieved, Tool Bit A must be returned to its original position so that the desired land may be cut.

Loosen the Set Screws holding Tool Bits A, D, and E.

Push Tool Bit A forward until it makes contact with the bottom of the slot.

**NOTE:**

Do not move Tool Bits D and E.

Rotate the Feed Sprocket for Tool Block No. 2 counter-clockwise to bring Tool Bits B and C back into contact with the bevel that they have previously cut.

Visually check the Feed Pin to Sprocket engagement for Tool Block No. 2.

Leave Tool Bits D and E in contact with the beveled surface made by Tool Bits B and C as shown.

Resume the pipe cutting operation.

Go back to “When the machining operation is finished...”.

## CUTTING SPEEDS

The chart shows RPM to obtain specified Tool Bit surface cutting speed on the surface of the pipe.

Cutting Speeds (approximate)				
Pipe Size		RPM for 200 in/min (508 cm/min)	RPM for 250 in/min (635 cm/min)	RPM for 300 in/min (762 cm/min)
30"	762 mm	2.1	2.7	3.2
28"	711 mm	2.3	2.8	3.4
26"	660 mm	2.4	3.0	3.7

Use 200 surface inches per minute (508 surface centimeters per minute) for: Stainless steels in general when no coolant is allowed, all heavy-wall tube and some of the chrome/molybdenum steels.

Use 250 surface inches per minute (635 surface centimeters per minute) for: Mild steels and some thin wall stainless steels when coolants are permitted and applied.

Use 300 surface inches per minute (762 surface centimeters per minute) for: Aluminum and thin-wall mild steel and tube with coolants.

# TOOL BITS

## SEVER TOOL BIT SETS

This Tool Bit Set will sever up to 1 3/8" (35.1 mm) wall with a 1/4" (6.4 mm) wide cut.

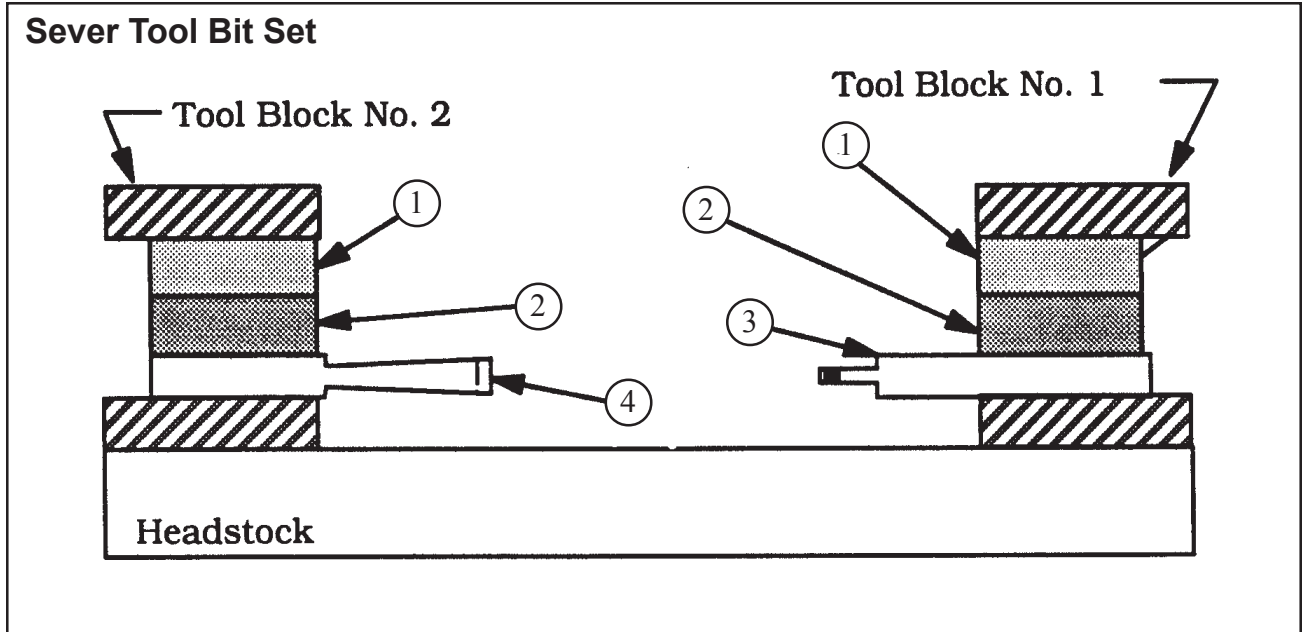

Item No.	Part No.	Description	Qty
1	30-0225	SPACER	2
2	30-0310	SPACER	2
3	99-1209	TOOL BIT, LEADING SEVER	1
4	99-1210	TOOL BIT, TRAILING SEVER	1

**SEVER TOOL BIT SETS**

This Tool Bit Set will sever up to 2 1/2" (63.5 mm) wall with a 1/2" (12.7 mm) wide cut.

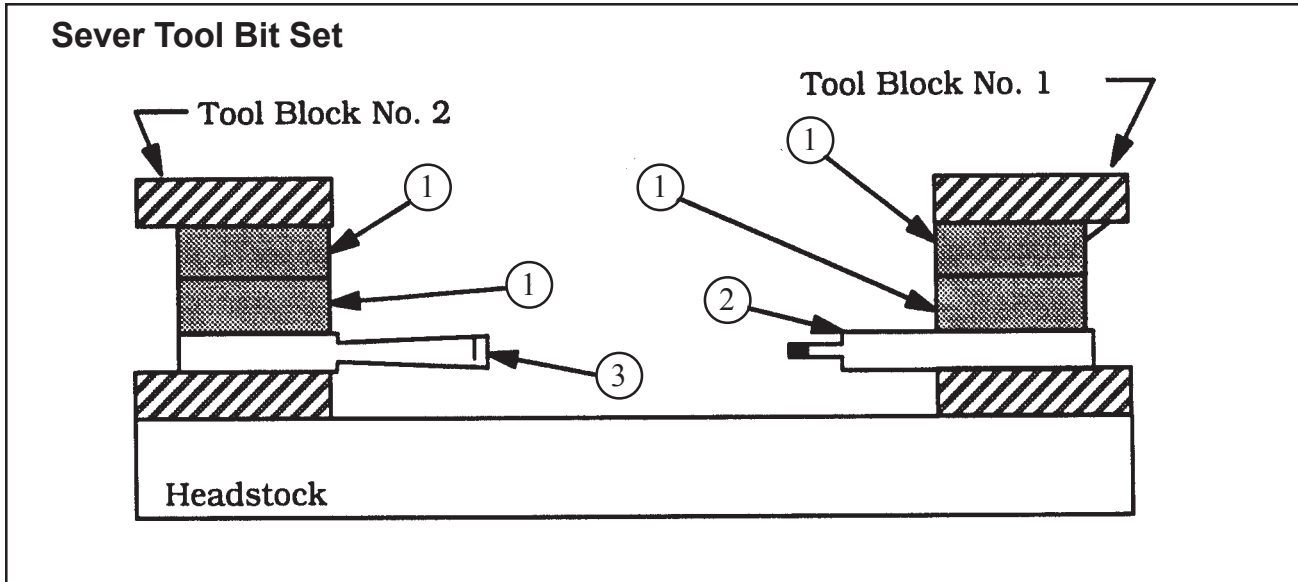

Item No.	Part No.	Description	Qty
1	30-0310	SPACER	4
2	99-0821	TOOL BIT, LEADING SEVER	1
3	99-0822	TOOL BIT, TRAILING SEVER	1



LEFT HAND SEVER AND SINGLE BEVEL TOOL BIT SETS

This Tool Bit Set will sever and 37.5° bevel up to a 1 1/4" (31.8 mm) wall on the pipe being cut off.

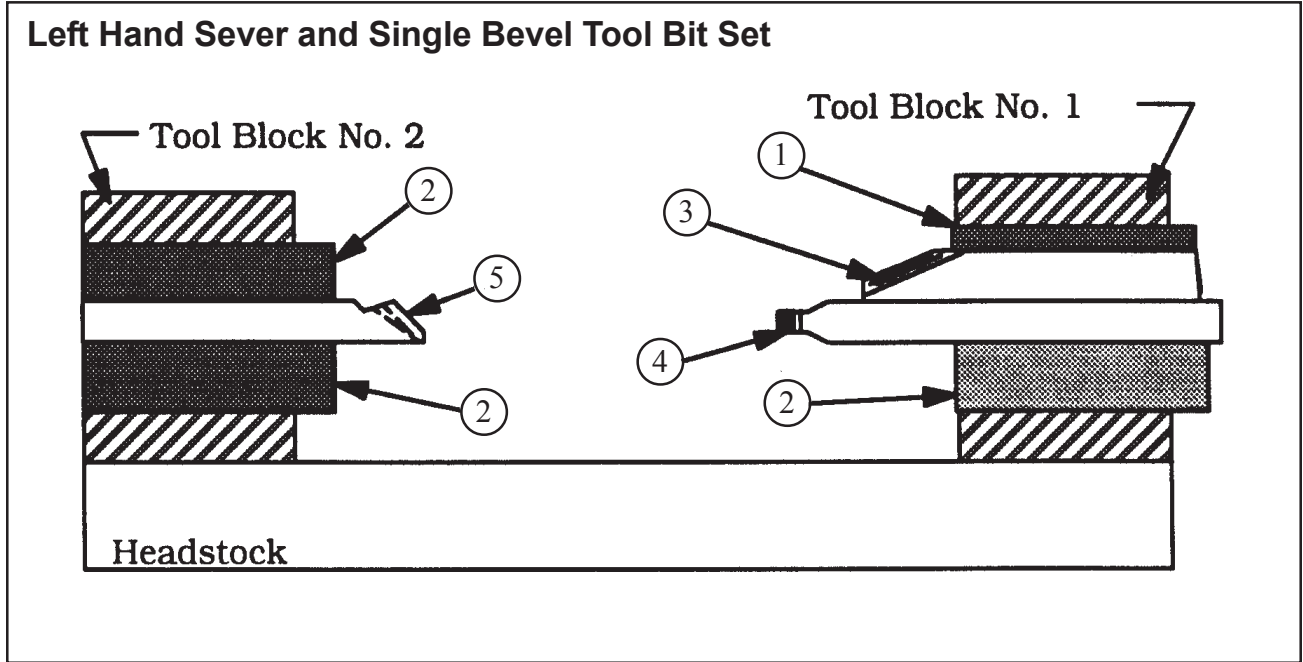

Item No.	Part No.	Description	Qty
1	30-0223	SPACER	1
2	30-0310	SPACER	3
3	99-4347	TOOL BIT, TRAILING BEVEL	1
4	99-4078	TOOL BIT, SEVER	1
5	99-4082	TOOL BIT, LEADING BEVEL	1

**RIGHT HAND SEVER AND SINGLE BEVEL TOOL BIT SETS**

This Tool Bit Set will sever and 37.5° bevel up to 1 1/4" (31.8 mm) wall on the pipe on which the Clamshell is mounted.

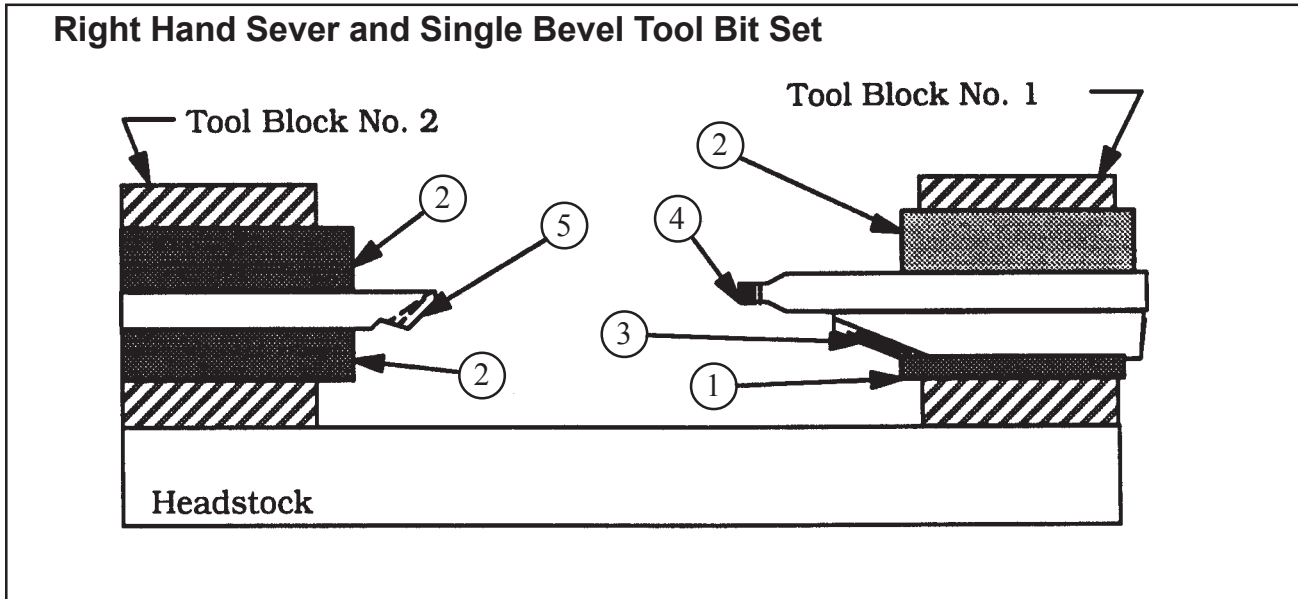

Item No.	Part No.	Description	Qty
1	30-0223	SPACER	1
2	30-0310	SPACER	3
3	99-4346	TOOL BIT, TRAILING BEVEL	1
4	99-4077	TOOL BIT, SEVER	1
5	99-4081	TOOL BIT, LEADING BEVEL	1

SEVER AND DOUBLE BEVEL TOOL BIT SETS

This Tool Bit Set will sever and 37.5° bevel on both sections of pipe up to 1 1/4" (31.8 mm) wall.

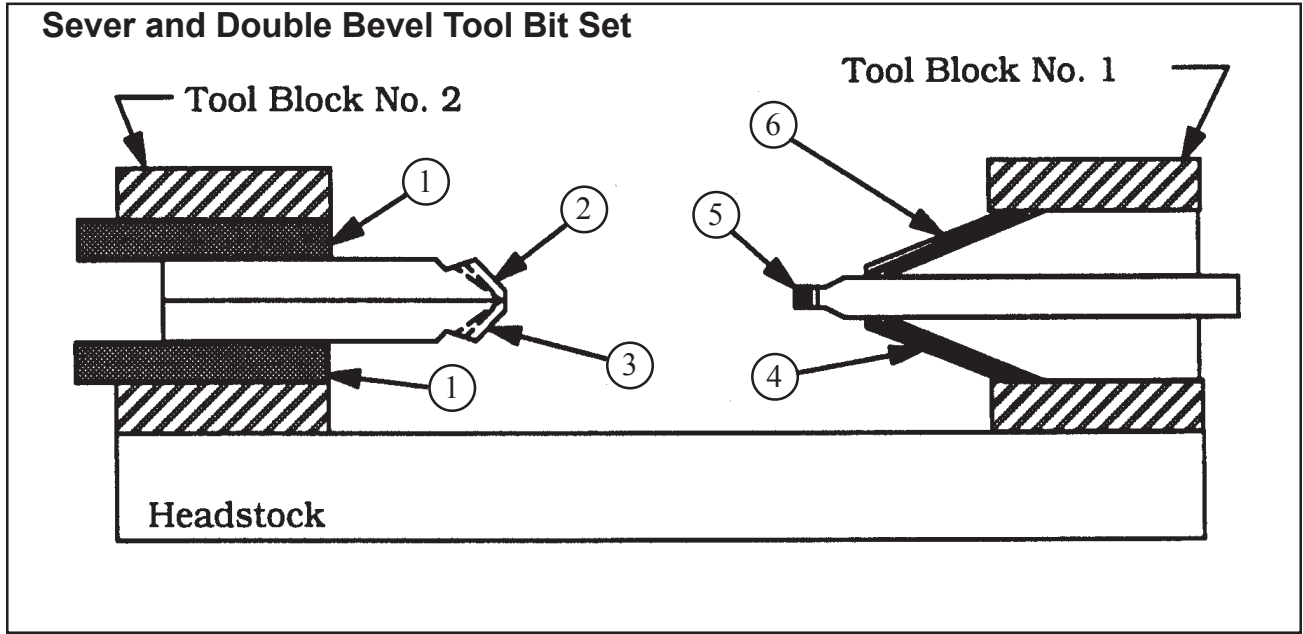

Item No.	Part No.	Description	Qty
1	30-0206	SPACER	2
2	99-0561	TOOL BIT, LEADING BEVEL, LH	1
3	99-0562	TOOL BIT, LEADING BEVEL, RH	1
4	99-4346	TOOL BIT, TRAILING BEVEL, RH	1
5	99-0564	TOOL BIT, SEVER	1
6	99-4347	TOOL BIT, TRAILING BEVEL, LH	1

**SEVER AND DOUBLE J-BEVEL TOOL BIT SETS**

This Tool Bit Set will sever and 22 1/2° bevel with a 3/16" (4.8 mm) radius J up to 1 3/8" (35.1 mm) wall both sections of pipe.

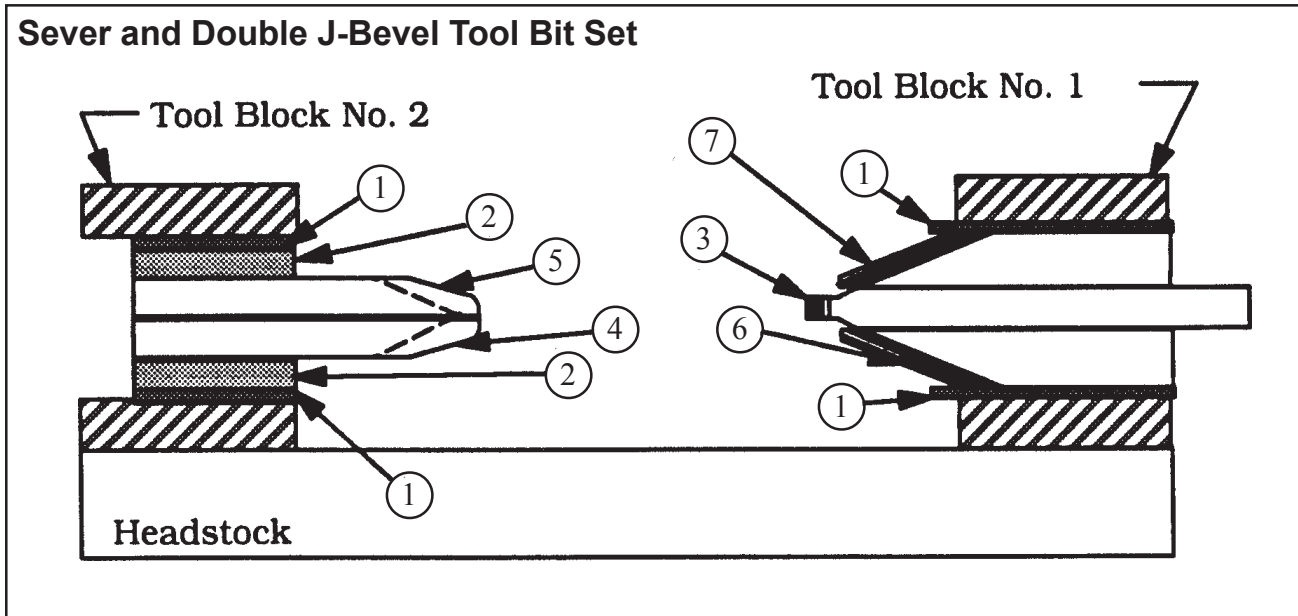

Item No.	Part No.	Description	Qty
1	30-0223	SPACER	4
2	30-0206	SPACER	2
3	99-1524	TOOL BIT, SEVER	1
4	99-2630	TOOL BIT, LEADING BEVEL, RH	1
5	99-2631	TOOL BIT, LEADING BEVEL, LH	1
6	99-2632	TOOL BIT, TRAILING BEVEL, RH	1
7	99-2633	TOOL BIT, TRAILING BEVEL, LH	1

SEVER AND DOUBLE COMPOUND BEVEL TOOL BIT SETS

This Tool Bit Set will sever and 37.5°/10° compound bevel with a 3/4" (19.1 mm) transition up to 1 3/8" (35.1 mm) wall.

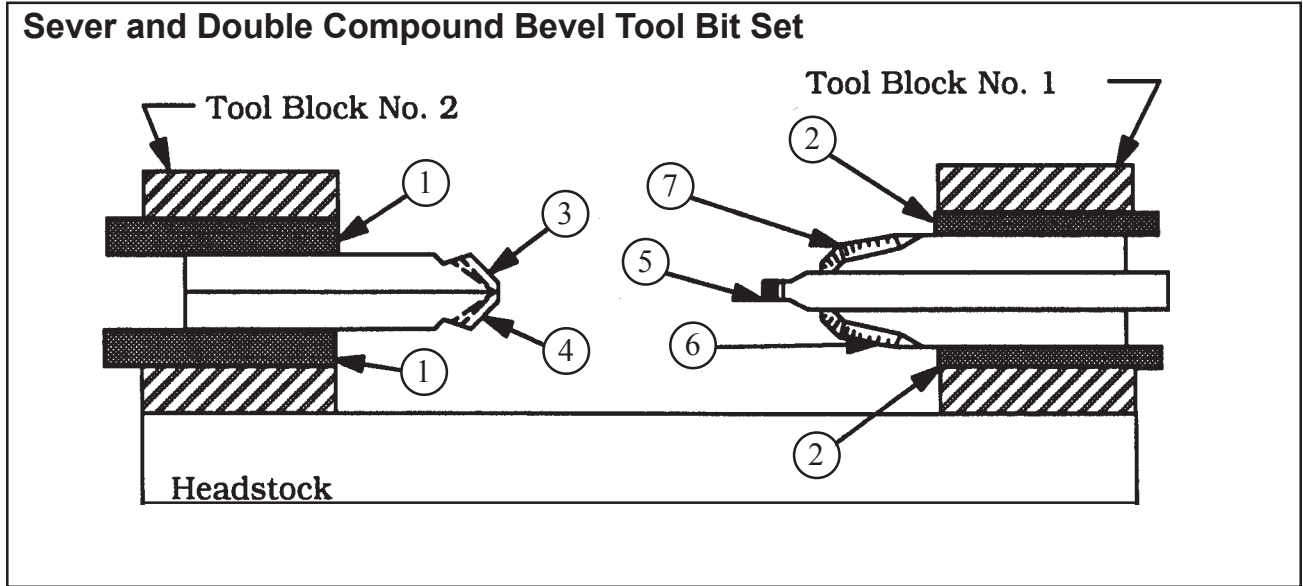

Item No.	Part No.	Description	Qty
1	30-0206	SPACER	2
2	30-0227	SPACER	2
3	99-0561	TOOL BIT, LEADING BEVEL, LH	1
4	99-0562	TOOL BIT, LEADING BEVEL, RH	1
5	99-0564	TOOL BIT, SEVER	1
6	99-0678	TOOL BIT, TRAILING BEVEL, RH	1
7	99-0679	TOOL BIT, TRAILING BEVEL, LH	1

**SEVER AND DOUBLE COMPOUND BEVEL TOOL BIT SETS**

This Tool Bit Set will sever and 37.5°/15° compound bevel with 3/4" (19.1 mm) transition up to 1 3/8" (35.1 mm) wall.

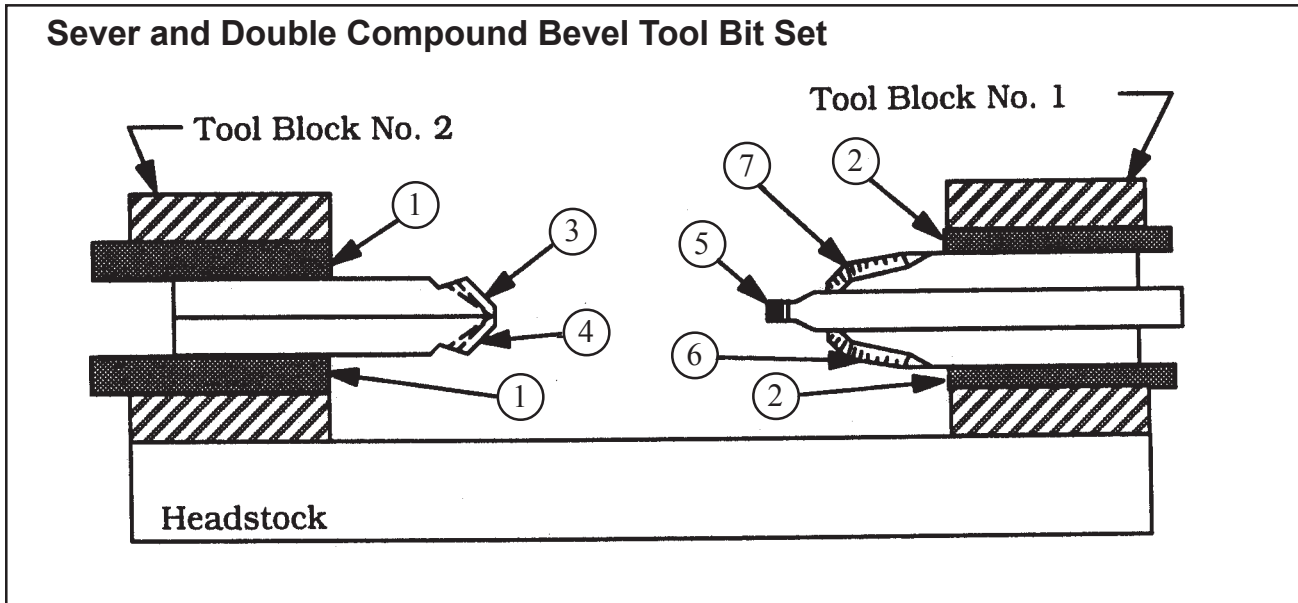

Item No.	Part No.	Description	Qty
1	30-0206	SPACER	2
2	30-0227	SPACER	2
3	99-0561	TOOL BIT, LEADING BEVEL, LH	1
4	99-0562	TOOL BIT, LEADING BEVEL, RH	1
5	99-0564	TOOL BIT, CUT-OFF	1
6	99-1442	TOOL BIT, TRAILING BEVEL, RH	1
7	99-1443	TOOL BIT, TRAILING BEVEL, LH	1

# CLAMPING PAD SETS

Clamping Pad Set

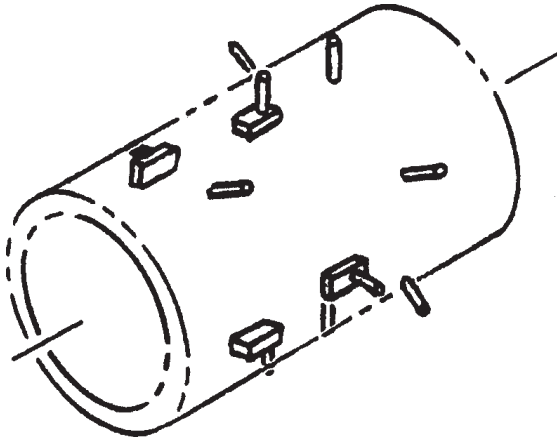

Clamping Pad Sets			
Pipe Diameter	True Outside Diameter		Clamping Bar Assy (4 req'd)
30"	30.00"	762 mm	26-0480
28"	28.00"	711 mm	26-0479
26"	26.00"	660 mm	26-0478

\*Contact TRI TOOL Inc. for sizes not listed

## TROUBLE SHOOTING

### **Problem: The Tool Bit Chatters**

**Probable causes:**

- The tool bit is loose or overextended.
- The tool bit is damaged.
- The tool holder is too loose in the slides.
- The cutting speed is too fast.
- The clamping pads are loose on the pipe or tube.
- Cutting fluid is required.
- The main bearing pre-load is loose.

### **Problem: There is excessive Tool Bit wear**

**Probable causes:**

- The pipe or tube material is too hard or abrasive.
- The cutting speed is too fast.
- Cutting fluid is required.
- A dull Tool Bit is causing surface hardening conditions (Stainless pipe or tubing).
- There is scale or other foreign matter on the pipe or tube, which is dulling the tool bit at the start of the cut.
- The tool bit is incorrect for the material being cut.

### **Problem: The Tool Bit is diving and the Clamshell is stalling**

**Probable causes:**

- The tool bit is dull, chipped, etc.
- The Tool Holder Adjustment Slide is too loose.
- The Parting Tool Bit is leading the Beveling Tool Bit by too much for proper chip clearance.
- The Tool Bit is over-extended.
- The Tool Holder is over-extended.
- The Main Bearing pre-load is too loose.

### **Problem: The surface finish is rough**

**Probable causes:**

- The tool bit is dull, chipped, etc.
- Metal build-up on the cutting edge of the tool bit is creating a false cutting edge.
- Cutting fluid is required.
- The cutting speed is incorrect.



**Problem: The Headstock is hard to rotate by hand**

**Probable causes:**

The Air Motor is still engaged.  
The Clamping Pads are too tight on the pipe or tube.  
Foreign material is on the mating surface of the split lines.  
Chips and/or other foreign material are in the rotating section.  
The Tool Bit is in contact with the pipe or tube.  
The Tool Block is in contact with the pipe or tube.  
The Main Bearing pre-load is too tight.

**Problem: The tool holder is not feeding**

**Probable causes:**

The feed pin is broken or out of position.  
The feed sprocket shear pin is broken.  
The feed screw is stripped.  
The feed nut is stripped.  
The slide rails are too tight.

**Problem: There is a loss of air power**

**Probable causes:**

Air supply pressure is too low.  
The Air filter is plugged.  
The Air Motor is not properly lubricated.  
The Exhaust is plugged.  
The Air Line size is insufficient.  
The Air Line is too long.  
The Motor is icing up because the water trap in the FRL has not been drained.

**Problem: The Clamshell is slipping on the pipe or tube**

**Probable causes:**

The Clamping Pads are not in full contact with the pipe or tube.  
The clamping pressure is too light.  
Scale and/or other foreign material is present on the pipe or tube.  
Weld seams, swelling, or bumps under the Clamping Pads are preventing full contact.  
Dull Tool Bits are causing extra force in the axial and/or radial direction.  
The pipe or tube wall is too thin which allows the tube wall to flex and the machine to move.

**Problem: The tool bit will not reach the work**

**Probable causes:**

Incorrect tool blocks are installed for the size of the pipe or tube being worked on.  
Incorrect tool bit is installed..

**Problem: The Air Motor will not start**

**Probable causes:**

The air supply is shut off.  
The Air Motor will not run free.  
The Air Motor needs lubrication.  
Add lubrication and do not run the Air Motor for a few minutes.  
Then try again.  
Tap on the Air Motor casing lightly with a piece of wood or with a soft rubber mallet.  
The vanes may be sticking.  
Sand or other foreign material is in the vanes of the Air Motor.

## **ACCESSORIES**

The following accessories are available for use with the Model 630SB Clamshell from TRI TOOL INC.

1. Portable Air Filter Caddy (P/N 75-0078)  
A FRL is required to protect the warranty on all TRI TOOL Inc. Air Driven Tools.
2. Tool Bits (Refer to the section 'Tool Bits')
3. Counterboring Module Kit (P/N 05-1260)
5. Heavy Duty Sever Tool Block Kit (Special Order Only)

# ILLUSTRATED PARTS BREAKDOWN

## MODEL 630SB CLAMSHELL SUB-ASSEMBLY

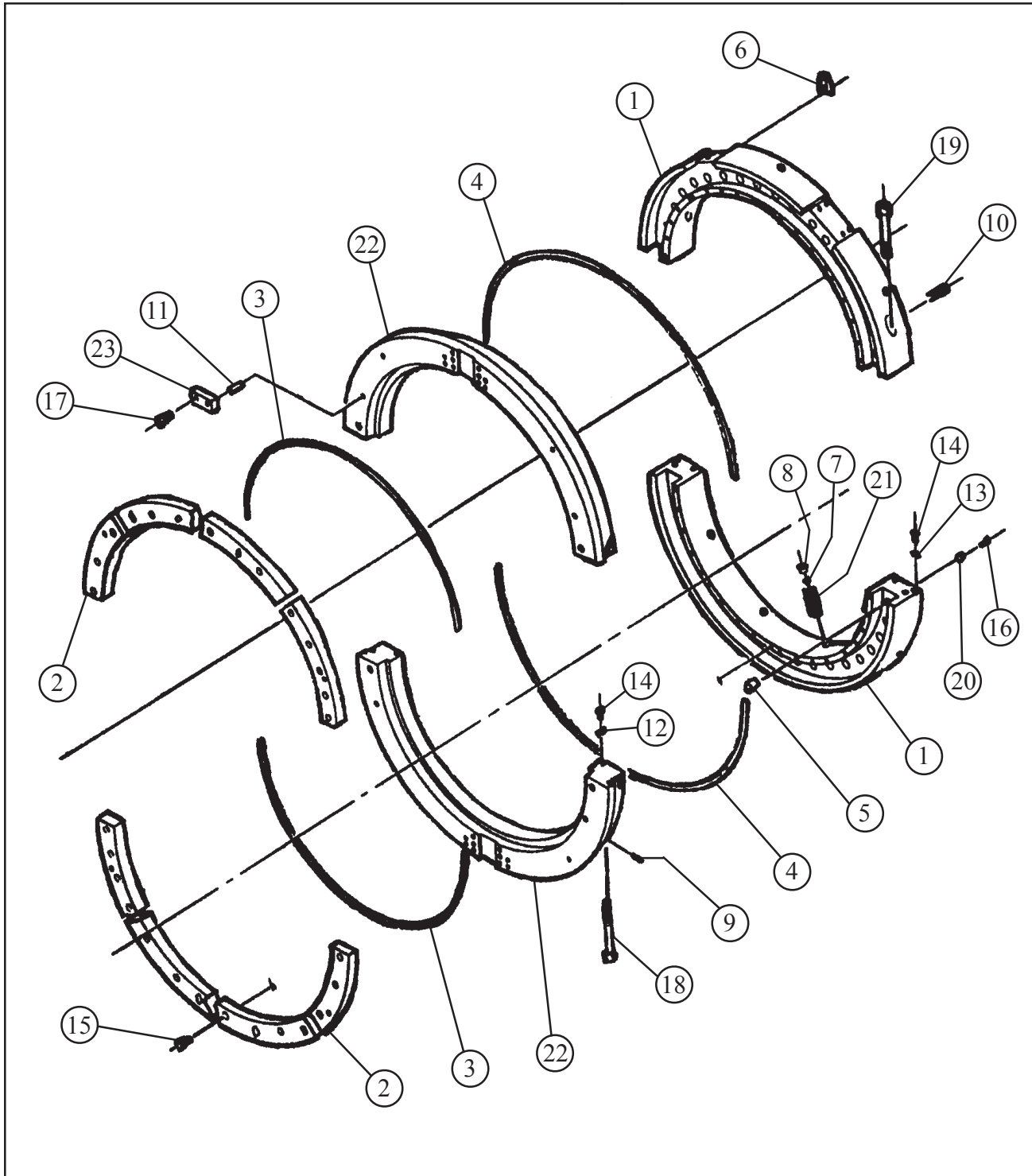

## Model 630SB, Low Profile Clamshell, Air

### Parts List, Model 630SB Clamshell Sub-Assembly

Item No.	Part No.	Description	Qty
1.	19-0423	HOUSING, MAIN	1 SET
2.	24-0674	PLATE, THRUST	8
3.	28-0057	SEAL, FELT	108" (274 cm)
4.	28-0057	SEAL, FELT	124" (315 cm)
5.	29-0209	BEARING, MAIN	24
6.	30-0304	RING, HOIST	4
7.	30-0615	BALL, STEEL	6
8.	30-0622	SADDLE	6
9.	32-0039	PIN, ROLL, 3/16 DIA X 1 1/2"	2
10.	33-0038	SCREW, CAP, 1/4-20 X 1/2"	2
11.	32-0105	PIN, DOWEL, 3/8 DIA X 1"	4
12.	32-0184	PIN, ALIGNMENT	2
13.	32-0235	PIN, ALIGNMENT	6
14.	33-0021	SCREW, CAP, #8-32 X 5/8"	8
15.	33-0057	SCREW, CAP, 5/16-18 X 1 1/4"	40
16.	33-0058	SCREW, CAP, 5/16-18 X 1 1/2"	24
17.	33-0071	SCREW, CAP, 3/8-16 X 1"	4
18.	33-0123	SCREW, CAP, 1/2-13 X 8"	2
19.	33-0184	SCREW, CAP, 1-8 X 4 1/2 "	2
20.	33-1340	SCREW, BEARING ADJUST	24
21.	33-1347	JACKSCREW, 1 1/4-7 X 6 3/4"	6
22.	39-0448	HEADSTOCK	1 SET
23.	48-0439	BLOCK, LOCK	4

JACKSCREW BLOCK ASSEMBLY

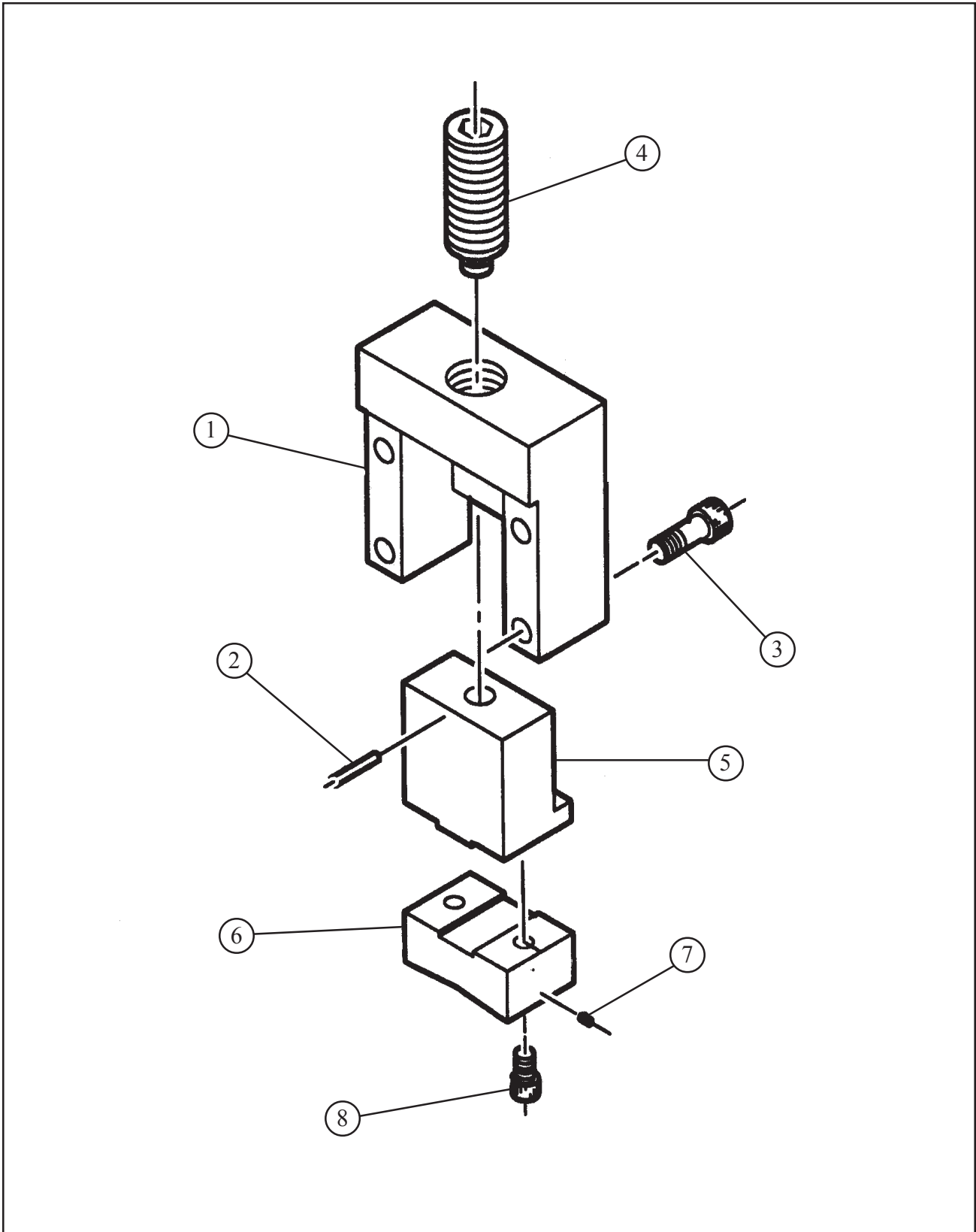

## Model 630SB Low Profile Clamshell, Air

### Parts List, Block Assembly, Jackscrew

Item No.	Part No.	Description	Qty
	08-0092	BLOCK ASSY, JACKSCREW	4
1.	19-0262	HOUSING	1
2.	32-0043	PIN, ROLL, 3/16 DIA X 1 1/4	1
3.	33-0110	SCREW, CAP, 1/2-13 X 2 1/4	4
4.	33-1343	SCREW, ADJUST, 1 1/4-7	1
5.	48-0315	BLOCK, GUIDE	1
	26-0478	BAR ASSY, CLAMPING	4
6.	26-0474	BAR, FIXED	1
7.	32-0290	PIN, ROLL, 1/8 DIA X 1/4	2
8.	33-0077	SCREW, CAP, 3/8-16 X 2 1/2	2
	26-0479	BAR ASSY, CLAMPING	4
6.	26-0475	BAR, FIXED	1
7.	32-0290	PIN, ROLL, 1/8 DIA X 1/4	2
8.	33-0073	SCREW, CAP, 3/8-16 X 1 1/2	2
	26-0480	BAR ASSY, CLAMPING	4
6.	26-0476	BAR, FIXED	1
7.	32-0290	PIN, ROLL, 1/8 DIA X 1/4	2
8.	33-0068	SCREW, CAP, 3/8-16 X 5/8	2
 NOT SHOWN:			
	05-1134	WRENCH KIT, 630SB	1
	36-0003	WRENCH, L, 3/32" HEX	1
	36-0007	WRENCH, L, 5/32" HEX	1
	36-0008	WRENCH, L, 3/16" HEX	1
	36-0009	WRENCH, L, 7/32" HEX	1
	36-0010	WRENCH, L, 1/4" HEX	1
	36-0011	WRENCH, L, 5/16" HEX	1
	36-0012	WRENCH, L, 3/8" HEX	1
	36-0014	WRENCH, L, 5/8" HEX	2
	36-0015	WRENCH, L, 3/4" HEX	1
	36-0021	WRENCH, T, 3/16" HEX	1
	36-0023	WRENCH, T, 1/4" HEX	1
	36-0024	WRENCH, T, 5/16" HEX	1
	36-0105	WRENCH, 1/2" DRIVE, HINGE	1
	36-0112	WRENCH, BEARING ADJUSTMENT	2
	36-0115	WRENCH, SPANNER	1
	36-0116	ADAPTOR, DRIVE SOCKET	1
	32-0084	PIN, DOWEL, 5/32 X 13/16	3

DRIVE HOUSING ASSEMBLY (P/N 19-0587)

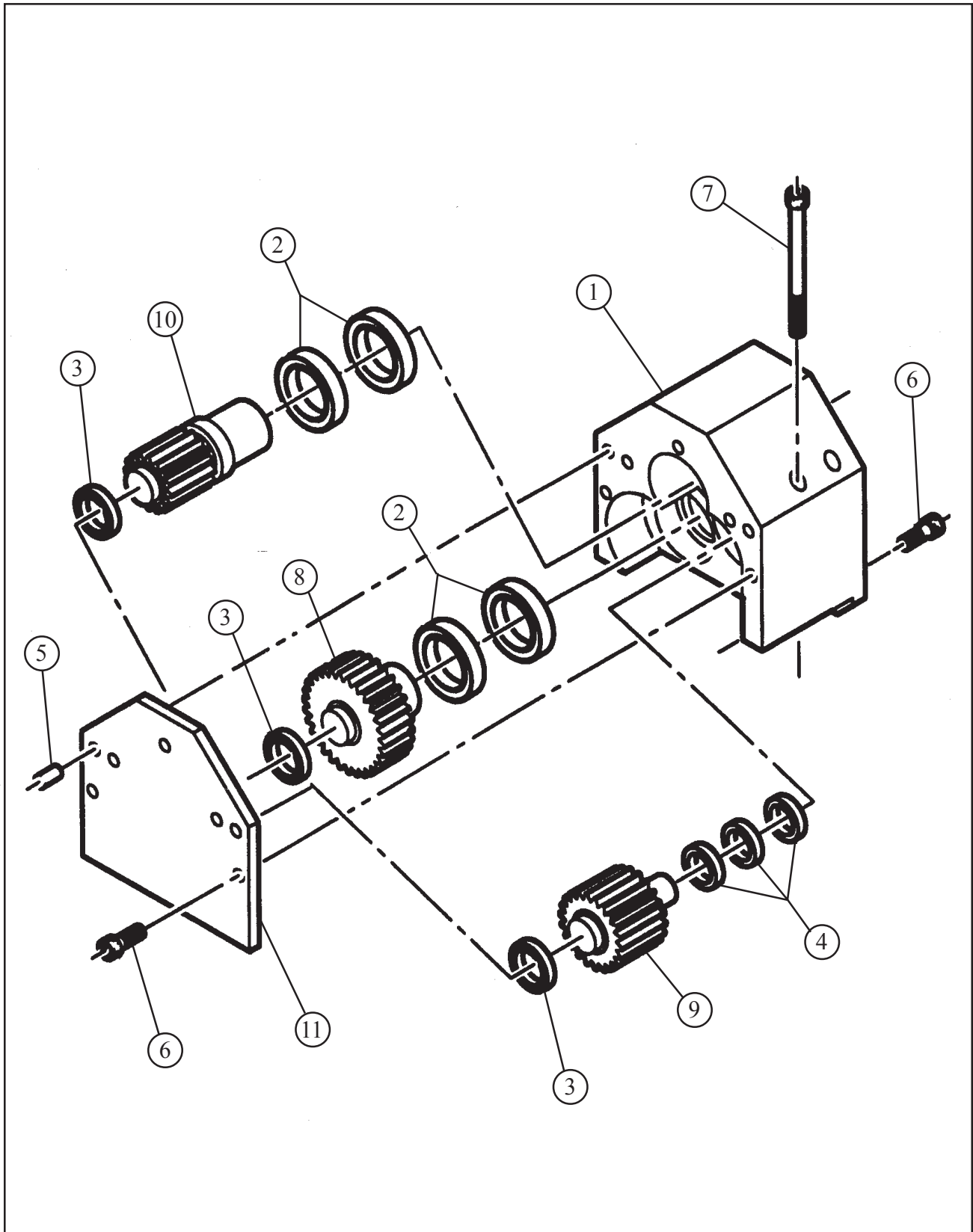



## Model 630SB Low Profile Clamshell, Air

---

Parts List, Housing Assembly, Drive (P/N 19-0587)

<b>Item No.</b>	<b>Part No.</b>	<b>Description</b>	<b>Qty</b>
1.	19-0263	HOUSING	1
2.	29-0005	BEARING, BALL	4
3.	29-0280	BEARING, BALL	3
4.	29-0162	BEARING, BALL	3
5.	32-0118	PIN, DOWEL, 3/8 DIA X 3/4	2
6.	33-0071	SCREW, CAP, 3/8-16 X 1	8
7.	33-0083	SCREW, CAP, 3/8-16 X 4 1/2	4
8.	39-0625	GEAR, SPUR, IDLER	1
9.	39-0626	GEAR, SPUR, IDLER	1
10.	39-0627	GEAR, SPUR, DRIVE	1
11.	43-0382	COVER	1

MOTOR ASSY, AIR (P/N 57-0166)

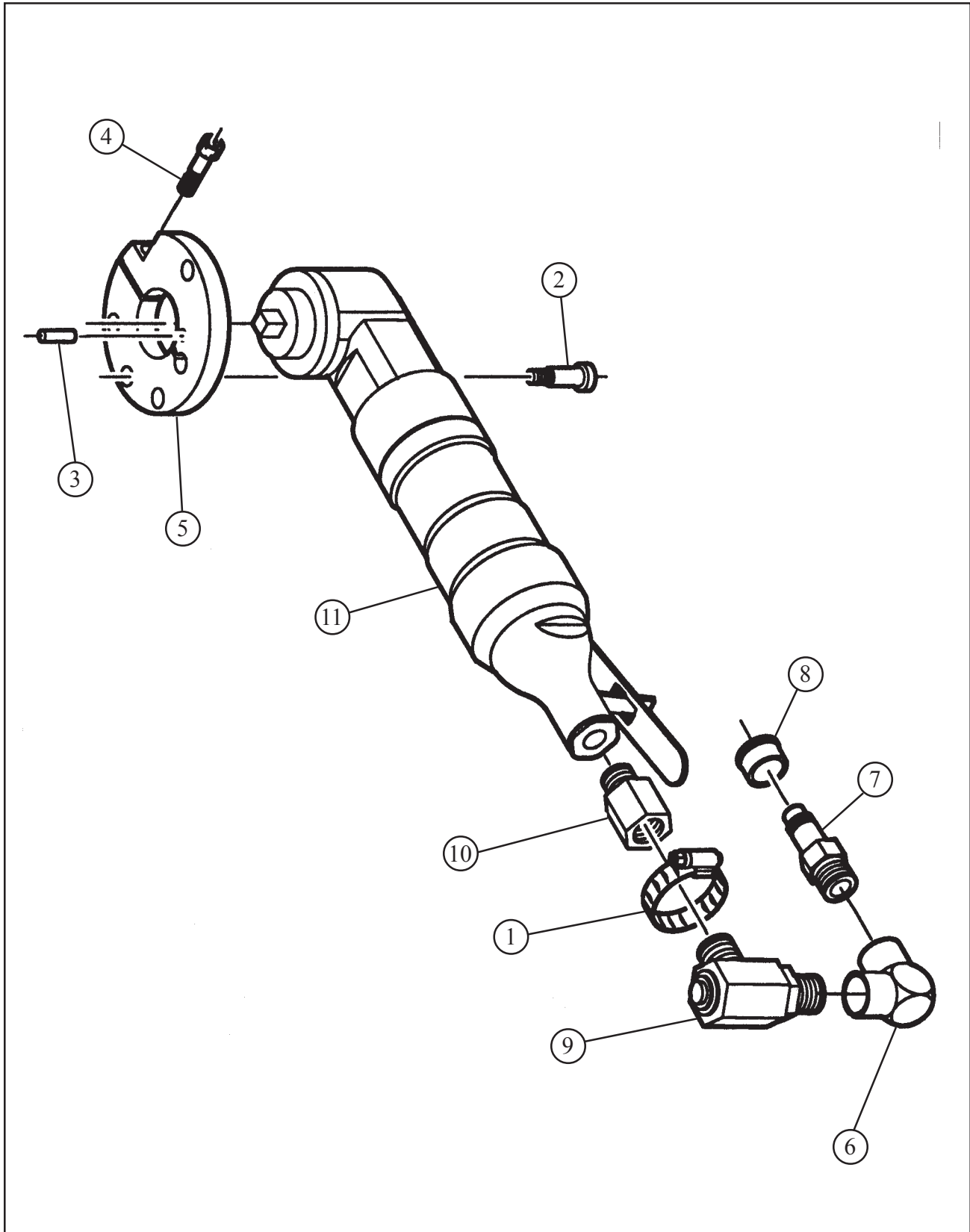

## Model 630SB Low Profile Clamshell, Air

---

Parts List, Motor Assembly, Air (P/N 57-0166)

<b>Item No.</b>	<b>Part No.</b>	<b>Description</b>	<b>Qty</b>
1.	30-0621	CLAMP, HOSE	1
2.	33-0945	SCREW, SHOULDER, 1/2 X 3/4	2
	47-0660	BRACKET ASSY, TORQUE RESTRAINT	1
3.	32-0257	PIN, DOWEL, 5/16 DIA X 7/8	1
4.	33-0073	SCREW, CAP, 3/8-16 X 1 1/2	1
5.	47-0658	BRACKET, TORQUE RESTRAINT	1
6.	54-0062	ELBOW, 90°	1
7.	54-0126	COUPLING, MALE, QUICK DISCONNECT	1
8.	54-0201	CAP, YELLOW	1
9.	54-0204	SWIVEL, JOINT	1
10.	54-0329	FITTING, EXTENSION, 1/2" PIPE	1
11.	57-0159	MOTOR, AIR	1

TOOL BLOCK (P/N 08-0169)

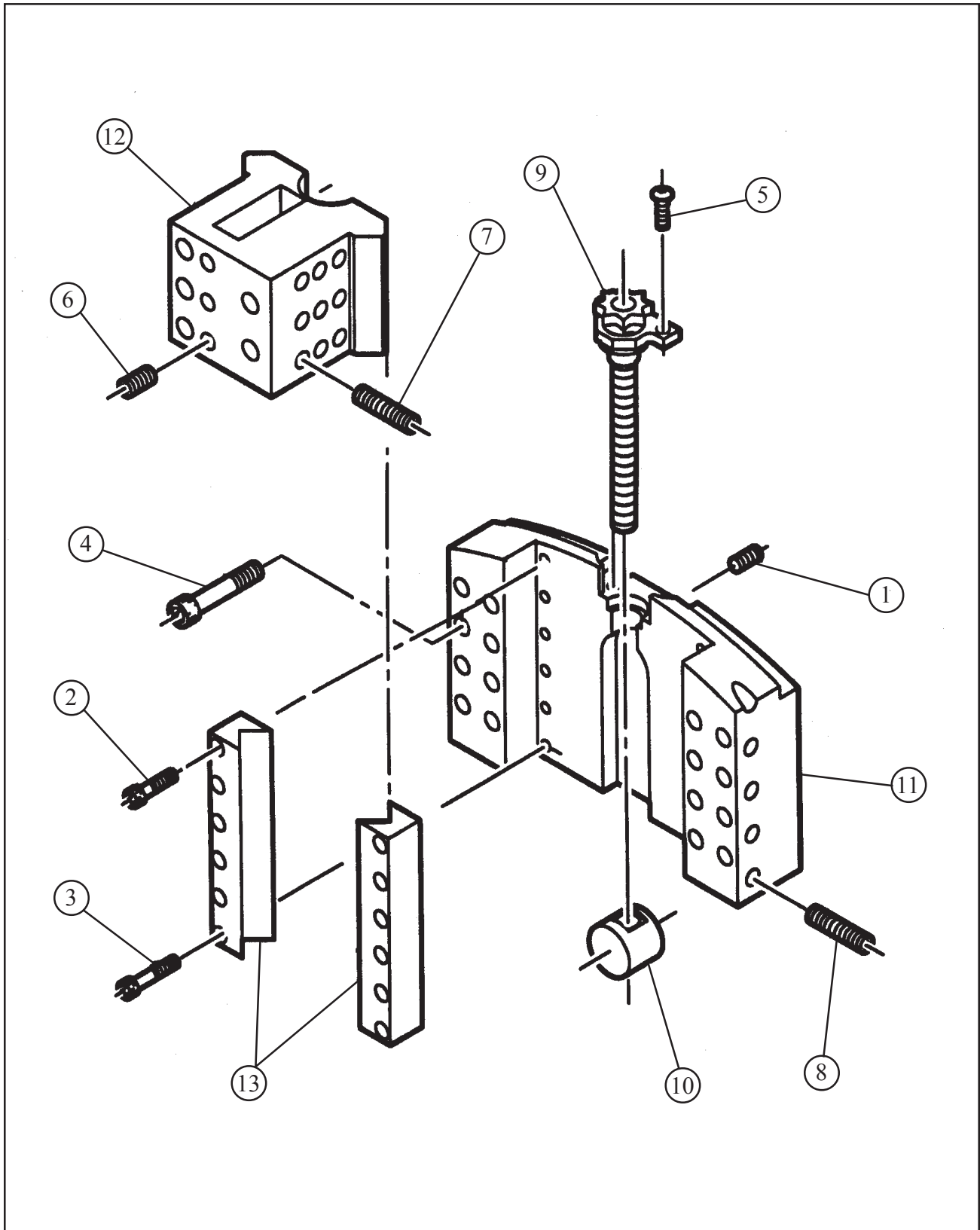

## Model 630SB Low Profile Clamshell, Air

---

Parts List, Tool Block (P/N 08-0169)

<b>Item No.</b>	<b>Part No.</b>	<b>Description</b>	<b>Qty</b>
1.	30-0464	PLUNGER, BALL	1
2.	33-0042	SCREW, CAP, 1/4-20 X 1	2
3.	33-0043	SCREW, CAP, 1/4-20 X 1 1/4	10
4.	33-0075	SCREW, CAP, 3/8-16 X 2	10
5.	33-0287	SCREW, BUTTON, 1/4-20 X 3/4	2
6.	33-0530	SCREW, SET, 3/8-16 X 5/8, CUP PT	3
7.	33-0531	SCREW, SET, 3/8-16 X 3/4, CUP PT	9
8.	33-1333	SCREW, SET, 3/8-24 X 1 1/2, HDOG	5
9.	33-1338	FEEDSCREW ASSY, 1/2-32	1
10.	35-0204	NUT, FEED	1
11.	47-0445	BRACKET, TOOL MODULE	1
12.	48-0309	HOLDER ASSY, TOOL	1
13.	66-0043	RAIL, SLIDE	2

TRIPPER BRACKET ASSEMBLY (P/N 47-0447)

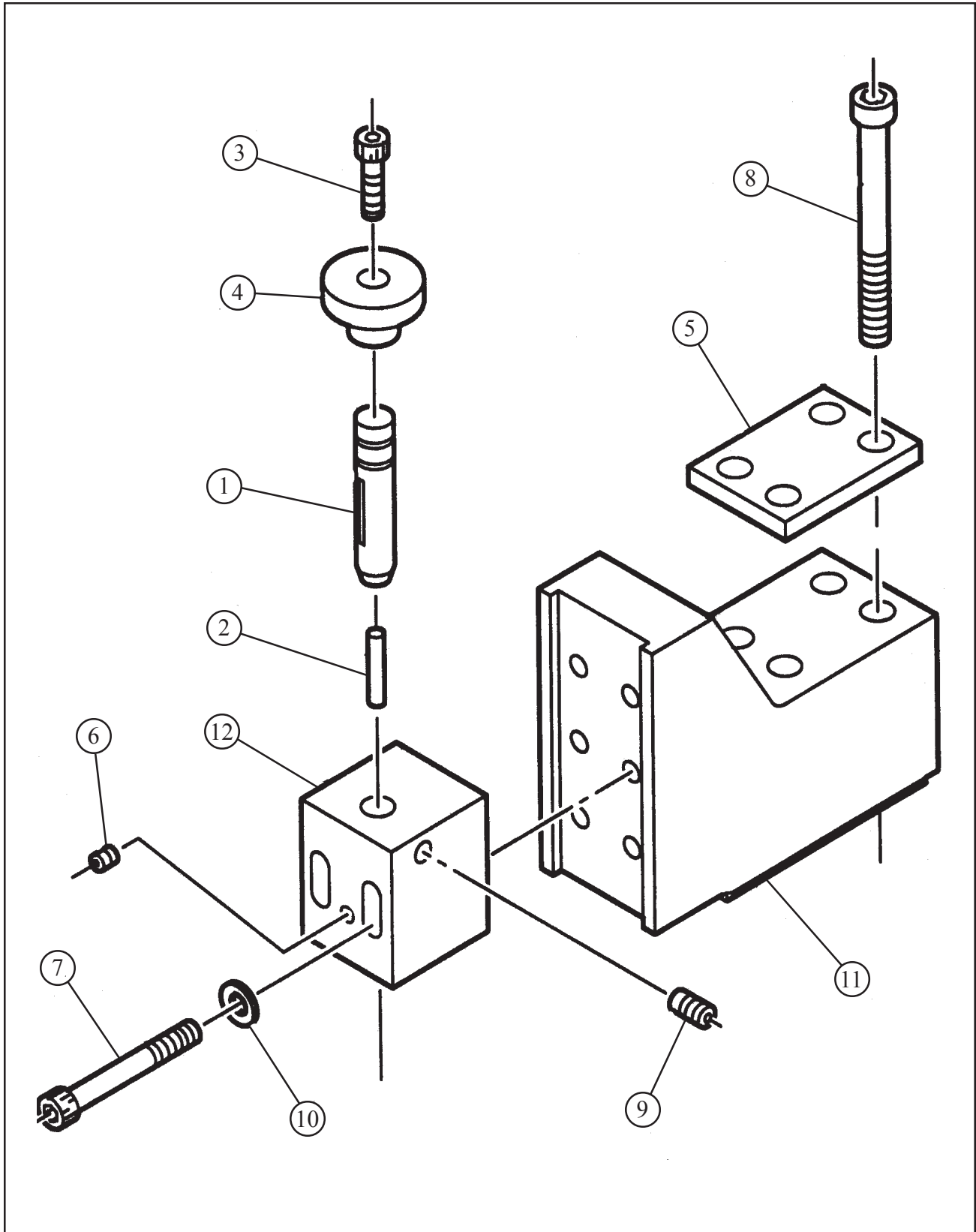

## Model 630SB Low Profile Clamshell, Air

---

Parts List, Bracket Assembly, Tripper (P/N 47-0447)

<b>Item No.</b>	<b>Part No.</b>	<b>Description</b>	<b>Qty</b>
	14-0011	SHAFT ASSY	1
1.	20-0023	SHAFT, TRIPPER	1
2.	32-0084	PIN, DOWEL, 5/32 X 13/16	1
3.	33-0030	SCREW, CAP, 10-24 X 3/4	1
4.	42-0023	KNOB, ROUND	1
5.	24-0452	PLATE, WASHER	1
6.	30-0125	PLUNGER, BALL	1
7.	33-0046	SCREW, CAP, 1/4-20 X 2	2
8.	33-0050	SCREW, CAP, 1/4-20 X 3	4
9.	33-0954	SCREW, SET, 10-24 X 1/4, HDOG	1
10.	34-0026	WASHER, FLAT	2
11.	47-0446	BRACKDT, TRIPPER	1
12.	48-0421	BLOCK, TRIPPER	1

**RECOMMENDED SPARES**

Recommended Spares for the Low Profile Clamshell

<b>Item No.</b>	<b>Part No.</b>	<b>Description</b>	<b>Qty</b>
1.	14-0011	SHAFT ASSY	2
2.	32-0027	PIN, FEED SPROCKET	2
3.	33-0043	SCREW, CAP, 1/4-20 X 1 1/4	2
4.	33-0075	SCREW, CAP, 3/8-16 X 2	20
5.	33-0287	SCREW, BUTTON, 1/4-20 X 3/4	4
6.	33-0530	SCREW, SET, 3/8-16 X 5/8, CUP PT	6
7.	33-0535	SCREW, SET, 3/8-16 X 1 1/2, CUP PT	18
8.	33-0965	SCREW, SHOULDER, 1/2 X 1	2
9.	33-1338	FEEDSCREW ASSY	2
10.	35-0204	NUT, FEED	2